

PRODUCT DATA DRAWING

REVISION HISTORY			
REV	DESCRIPTION	DATE	APPROVED
-	NRN 44033	06/19	STW

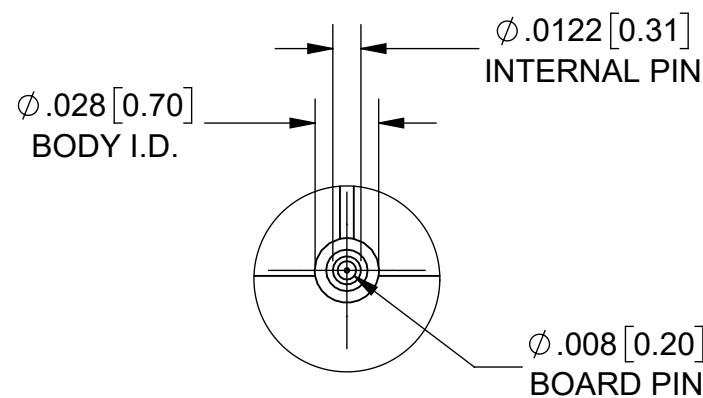

DETAIL A
SCALE 12 : 1

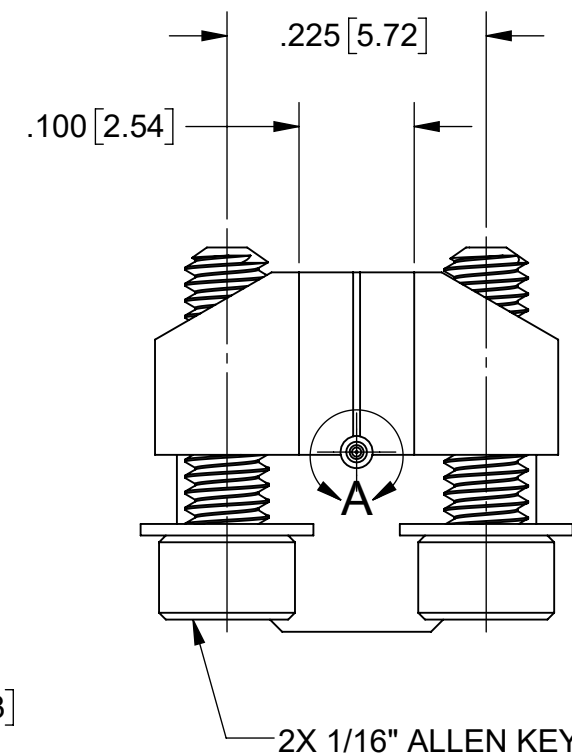
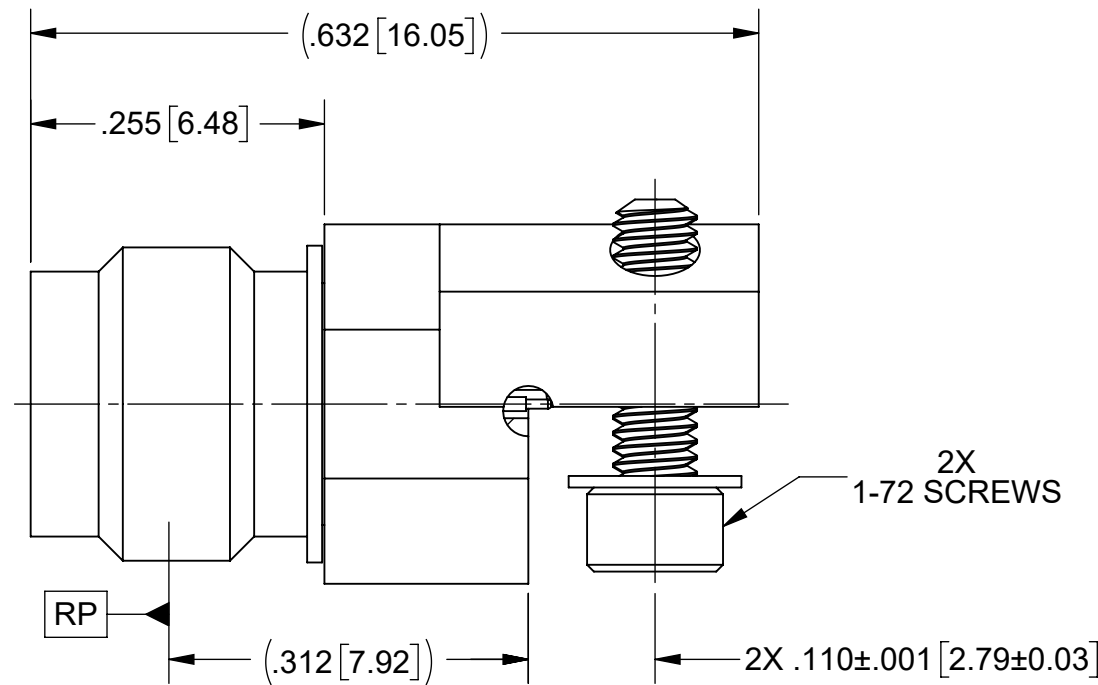
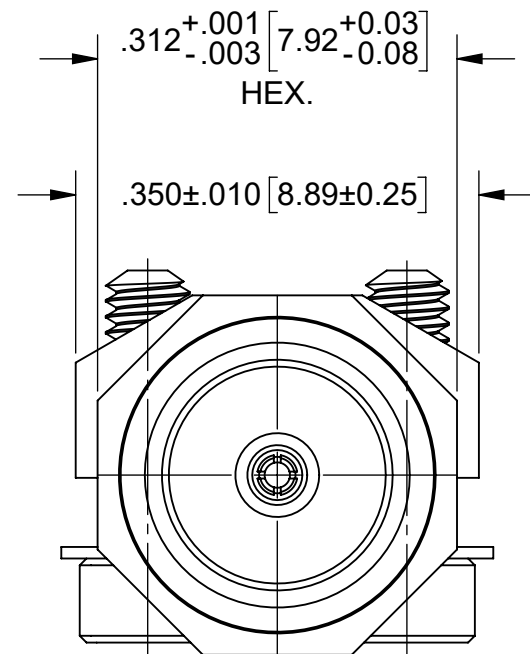
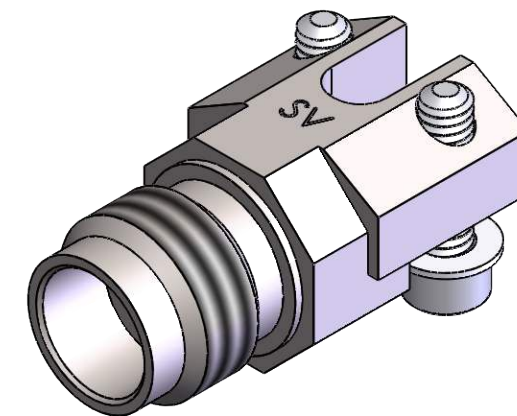

MATERIAL:

BODY: STAINLESS STEEL PER AMS-5640, ALLOY UNS S30300, TYPE 1; OR ASTM A582 TYPE 303, COND. A

CONTACT: BERYLLIUM COPPER PER ASTM B196, ALLOY No. UNS C17300, TD04

BEAD: ULTEM 1000 PER ASTM D5205

FINISH:

BODY: PASSIVATED PER AMS-2700

CONTACT: GOLD PER ASTM B488, TYPE II, CODE C, CLASS 1.27, OVER NICKEL PER AMS 2404, CLASS 4, .00005" MIN.

PERFORMANCE:

IMPEDANCE: 50 OHMS

FREQ. RANGE: DC TO 67.0 GHz

VSWR: 1.25:1 MAX. DC TO 67.0 GHz

NOTES:

- FOR A FOOTPRINT RECOMMENDATION SPECIFIC TO YOUR PCB, PLEASE CONTACT US AT applications@svmicro.com

MATERIAL: SEE NOTES	DIMENSIONS ARE IN INCHES TOLERANCES: FRACTIONAL: ±1/64 ANGULAR: X° ±1'0" X'X' ±15'	UNLESS OTHERWISE SPECIFIED 1) ALL DIMENSIONS ARE IN INCHES (MILLIMETERS) 2) ALL DIMENSIONS ARE AFTER PLATING. 3) BREAK CORNERS & EDGES .005 R. MAX. 4) CHAM. 1ST & LAST THREADS. 5) SURFACE ROUGHNESS 63-MIL-STD-10. 6) DIA: 'S ON COMMON CENTERS TO BE CONCENTRIC WITHIN .005 T.I.R. 7) REMOVE ALL BURRS	 Amphenol 2400 Centrepark West Drive, Suite 100 West Palm Beach, FL 33409 TITLE: 1.85mm FEMALE EDGE LAUNCH CONNECTOR WITH Ø.008 LAUNCH PIN
FINISH: SEE NOTES	DECIMAL: X ±.030 .XX ±.010 .XXX ±.005	INTERPRET DIMENSIONS AND TOLERANCES PER ASME Y14.5M - 1994	
SURFACE AREA: N/A	THIRD ANGLE PROJECTION	DRAWN: JDC 06/19/19	SIZE: B CAGE CODE: 95077 DWG. NO. SF3321-60040
PROPRIETARY THE INFORMATION CONTAINED IN THIS DRAWING IS THE SOLE PROPERTY OF SV MICROWAVE, INC. ANY REPRODUCTION IN PART OR AS A WHOLE WITHOUT THE WRITTEN PERMISSION OF SV MICROWAVE, INC IS PROHIBITED.		CHECKED: STW 06/19/19	SCALE: 6:1
		APPROVED: STW 06/19/19	SHEET 1 OF 1