



GlobalTech Display

A Professional LCD Displays Provider

TFT LCD Display Specification

PN: GLT035240320WH1

Overview:

- 3.5" Diagonal
- Wide View Angle
- Driver: ST7789V2
- 262K Colors
- 500 Nits
- 240 x 320 Pixels
- Normally White
- SPI
- No Touch Panel
- RoHS Compliant

9825 Widmer Road, Lenexa, KS 66215, USA | Tel: 913-828-5685 Fax: 913-273-4397

Email: sales@gtdisplays.com Website: www.gtdisplays.com

Table of Contents

1. Record of Revision.....	2
2. General Specifications.....	3
3. Input / Output Terminals.....	4
4. Absolute Maximum Rating.....	5
5. Electrical Characteristics.....	5
6. Interface Timing.....	6
7. Optical Characteristics.....	8
8. Environmental / Reliability Tests.....	11
9. Mechanical Drawing.....	13
10. Packing.....	14
11. TFT-LCD Module Inspection Criteria.....	15
12. Precautions for Use of LCD modules.....	19

1. Record of Revision

Rev	Issued Date	Description	Editor
1.0	10/07/2021	First Release	ZWF
2.0	12/03/2021	First Release	ZWF

2. General Specifications

Feature		Spec
Characteristics	Size	3.5 inch
	Resolution	240(Horizontal) x 320(Vertical)
	Interface	SPI
	Connect type	Connector
	Display Colors	262K
	Technology type	a-Si
	Pixel pitch (mm)	0.219 x 0.219
	Pixel Configuration	R.G.B.-Stripe
	Display Mode	Normally White
	LCD Driver IC	ST7789V2
	Viewing Direction	75/75/75/75
Mechanical	LCM (W x H x D) (mm)	60.00 x 81.50 x 3.65
	Active Area (mm)	52.56 x 70.08
	With / Without TSP	No
	Weight (g)	~28g
	LED Numbers	6 LEDs

Note 1: Requirements on Environmental Protection: RoHs

Note 2: LCM weight tolerance: +/- 5%

3. Input / Output Terminals

LCD PIN-MAP

No.	Symbol	Description
1	VCC	Interface I/O Power supply (2.8V)
2	GND	Power Ground
3	RESET	Reset signal pin
4	CSX	Chip select pin
5	DCX	data for the 4 line serial interface
6	GND	Power Ground
7	SCL	clock for 4 line serial interface
8	SDI	Serial input signal
9	SDO	Serial input signal
10	GND	Power Ground
11-12	LEDA	LED Anode A
13-14	LEDK	LED Cathode K

4. Absolute Maximum Rating

Item	Symbol	MIN	Typ	MAX	Unit	Remark
Supply Voltage	VDD	-0.3	-	4.8	V	-
Operating Temperature	TOPR	-20	-	70	°C	-
Storage Temperature	TSTG	-30	-	80	°C	

5. Electrical Characteristics

5.1 Driving TFT LCD Panel

Item	Symbol	MIN	TYP	MAX	Unit	Remark	
Analog Supply Voltage	V _{CC}	2.5	3.3	3.6	V		
Input Signal Voltage	Low Level	V _{IL}	V _{SS}	-	0.3x IOVCC	V	
	High Level	V _{IH}	0.7x IOVCC	-	IOVCC	V	

5.2 LED Driving Conditions

Item	Symbol	MIN	TYP	MAX	Unit	Remark
Forward Current (single string)	I _F	-	20	-	mA	
Forward Voltage (single string)	V _F	8.1	-	10.2	V	
Backlight Power consumption	W _{BL}	0.324	-	0.408	W	
LED Lifetime		-	30,000	-	Hrs	

Note 1: Each LED: I_{Fmax} = 20 mA, V_F =2.7-3.4V.

Note 2: Optical performance should be evaluated at Ta=25°C only.

Note 3: If LED is driven by high current, high ambient temperature & humidity condition. The life Time of LED will be reduced. Operating life means brightness goes down to 50% initial brightness. Typical operating life time is estimated data.

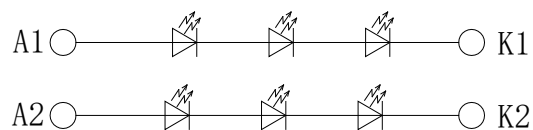

LED CIRCUIT DIAGRAM

6. Interface Timing

6.1 Serial Interface Characteristics (3-line serial)

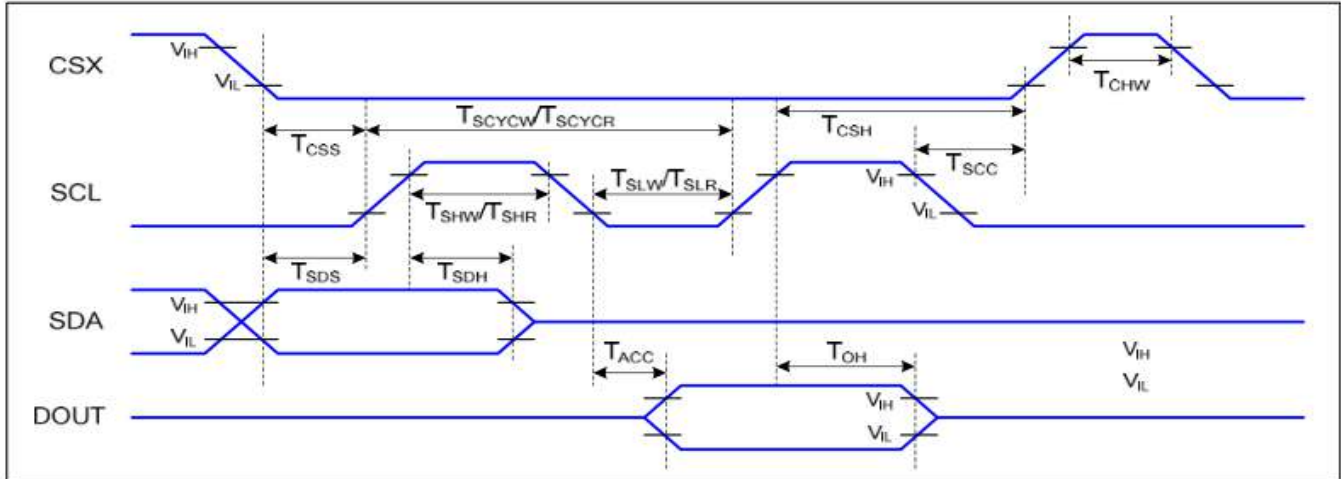

Figure 4 3-line serial Interface Timing Characteristics

$V_{DDI}=1.65$ to $3.3V$, $V_{DD}=2.4$ to $3.3V$, $AGND=DGND=0V$, $T_a=25^{\circ}C$

Signal	Symbol	Parameter	Min	Max	Unit	Description
CSX	T_{CSS}	Chip select setup time (write)	15		ns	
	T_{CSH}	Chip select hold time (write)	15		ns	
	T_{CSS}	Chip select setup time (read)	60		ns	
	T_{SCC}	Chip select hold time (read)	65		ns	
	T_{CHW}	Chip select "H" pulse width	40		ns	
SCL	T_{SCYCW}	Serial clock cycle (Write)	16		ns	
	T_{SHW}	SCL "H" pulse width (Write)	7		ns	
	T_{SLW}	SCL "L" pulse width (Write)	7		ns	
	T_{SCYCR}	Serial clock cycle (Read)	150		ns	
	T_{SHR}	SCL "H" pulse width (Read)	60		ns	
	T_{SLR}	SCL "L" pulse width (Read)	60		ns	
SDA (DIN)	T_{SDS}	Data setup time	7		ns	
	T_{SDH}	Data hold time	7		ns	
DOUT	T_{ACC}	Access time	10	50	ns	For maximum $CL=30pF$
	T_{OH}	Output disable time	15	50	ns	For minimum $CL=8pF$

Table 5 3-line serial Interface Characteristics

6.2 Serial Interface Characteristics (4-line serial)

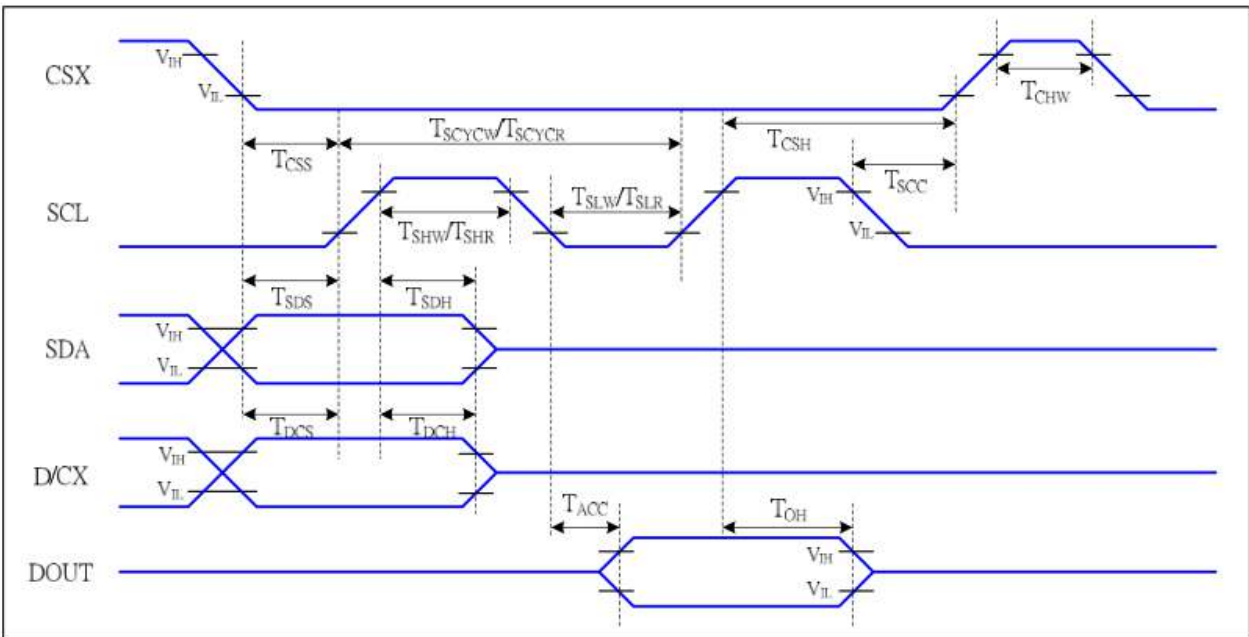

Figure 5 4-line serial Interface Timing Characteristics

V_{DDI}=1.65 to 3.3V, V_{DD}=2.4 to 3.3V, A_{GN}D=D_{GN}D=0V, T_a=25°C

Signal	Symbol	Parameter	MIN	MAX	Unit	Description
CSX	T _{CSS}	Chip select setup time (write)	15		ns	
	T _{CSH}	Chip select hold time (write)	15		ns	
	T _{CSS}	Chip select setup time (read)	60		ns	
	T _{SCC}	Chip select hold time (read)	65		ns	
	T _{CHW}	Chip select "H" pulse width	40		ns	
SCL	T _{SCYCW}	Serial clock cycle (Write)	16		ns	-write command & data ram
	T _{SHW}	SCL "H" pulse width (Write)	7		ns	
	T _{SLW}	SCL "L" pulse width (Write)	7		ns	
	T _{SCYCR}	Serial clock cycle (Read)	150		ns	-read command & data ram
	T _{SHR}	SCL "H" pulse width (Read)	60		ns	
	T _{SLR}	SCL "L" pulse width (Read)	60		ns	
D/CX	T _{DCS}	D/CX setup time	10		ns	
	T _{DCH}	D/CX hold time	10		ns	
SDA (DIN)	T _{SDS}	Data setup time	7		ns	
	T _{SDH}	Data hold time	7		ns	
DOUT	T _{ACC}	Access time	10	50	ns	For maximum CL=30pF
	T _{OH}	Output disable time	15	50	ns	For minimum CL=8pF

Table 6 4-line serial Interface Characteristics

7. Optical Characteristics

Items	Symbol	Condition	Min.	Typ.	Max.	Unit	Remark	Note
Response time	Tr+Tf	-	-	25	50	ms	FIG.1	Note4
Contrast Ratio	CR		350	400	-	-	FIG.2	Note1
Surface luminance	LV	$\theta=0^\circ$	400	500	-	cd/m2	FIG.2	Note2
Luminance uniformity	Yu	$\theta=0^\circ$	80	-	-	%	FIG.2	Note3
NTSC	-	$\theta=0^\circ$	-	60	-	%	FIG.2	Note5
Viewing angle	θ_T	Center CR \geq 10	-	75	-	deg	FIG.3	Note6
	θ_B		-	75	-	deg	FIG.3	
	θ_L		-	75	-	deg	FIG.3	
	θ_R		-	75	-	deg	FIG.3	
Chromaticity	Red	R_X	0.581	0.631	0.681	-	FIG.2 CIE1931	Note5
		R_Y	0.273	0.323	0.373	-		
	Green	G_X	0.245	0.295	0.345	-		
		G_Y	0.525	0.575	0.625	-		
	Blue	B_X	0.093	0.143	0.193	-		
		B_Y	0.053	0.103	0.153	-		
	White	W_X	0.250	0.300	0.350	-		
		W_Y	0.270	0.320	0.370	-		

Note1. Definition of contrast ratio

Contrast ratio (Cr) is defined mathematically by the following formula. For more information see FIG.2.

$$\text{Contrast ratio} = \frac{\text{Luminance measured when LCD on the "White"}}{\text{Luminance measured when LCD on the "Black"}}$$

For contrast ratio, Surface Luminance, Luminance uniformity and CIE, the testing data is based on TOPCON's BM-5 or BM-7 photo detector or compatible.

Note2. Definition of surface luminance

Surface luminance is the luminance with all pixels displaying white. For more information see FIG.2.

L_v = Average Surface Luminance with all white pixels (P1,P2,P3,,Pn)

Note3. Definition of luminance uniformity

The luminance uniformity in surface luminance is determined by measuring luminance at each test position 1 through n, and then dividing the maximum luminance of n points luminance by minimum luminance of n points luminance. For more information see FIG.2.

$$YU = \frac{\text{Minimum surface luminance with all white pixels (P1,P2,P3,.....,Pn)}}{\text{Maximum surface luminance with all white pixels (P1,P2,P3,.....,Pn)}}$$

Note4. Definition of response time

The response time is defined as the LCD optical switching time interval between “White” state and “Black” state. Rise time (Tr) is the time between photo detector output intensity changed from 90% to 10%. And fall time (Tf) is the time between photo detector output intensity changed from 10% to 90%. For additional information see FIG1.

Note5. Definition of color chromaticity (CIE1931)

CIE (x,y) chromaticity, The x,y value is determined by screen active area center position P5. For more information see FIG.2.

Note6. Definition of viewing angle

Viewing angle is the angle at which the contrast ratio is greater than 10. Angles are determined for the horizontal or x axis and the vertical or y axis with respect to the z axis which is normal to the LCD surface. For more information see FIG.3.

For viewing angle and response time testing, the testing data is base on Autronic-Melchers’s ConoScope or DMS series Instruments or compatible.

FIG.1. The definition of response Time

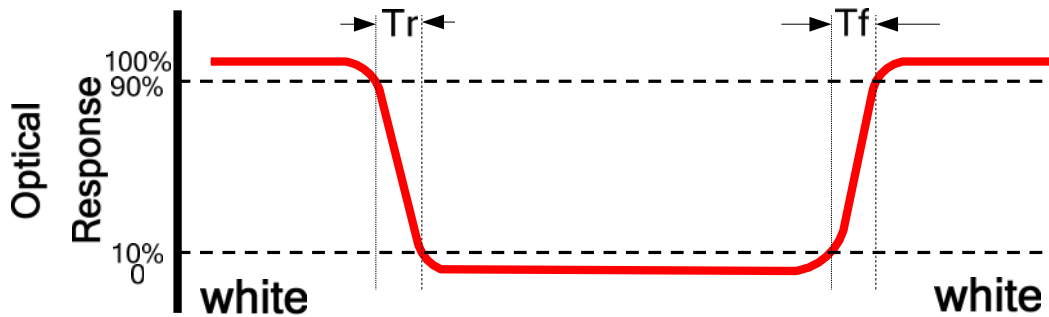

FIG.2. Measuring method for contrast ratio, surface luminance, luminance uniformity, CIE (x,y) chromaticity

Size: $S \leq 5"$ (see Figure a) A : 5mm B: 5mm
 H,V: Active area
 Light spot size $\phi=5\text{mm}$ (BM-5) or $\phi=7.7\text{mm}$ (BM-7) 50cm distance or compatible distance from the LCD surface to detector lens.
 Test spot position: see Figure a.
 Measurement instrument: TOPCON’s luminance meter BM-5 or BM-7 or compatible (see Figure c).

Size: $5" < S \leq 12.3"$ (see Figure b) H,V: Active area
 Light spot size $\phi=5\text{mm}$ (BM-5) or $\phi=7.7\text{mm}$ (BM-7) 50cm distance or compatible distance from the LCD surface to detector lens.
 Test spot position : see Figure b.
 Measurement instrument: TOPCON’s luminance meter BM-5 or BM-7 or compatible (see Figure c).

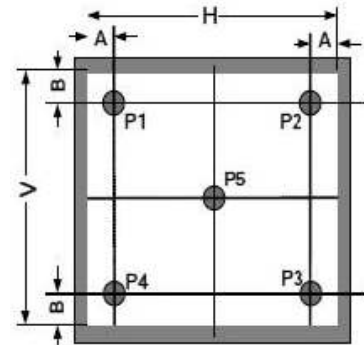

Figure a

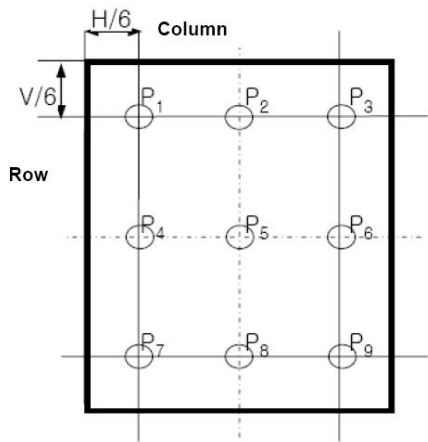

Figure b

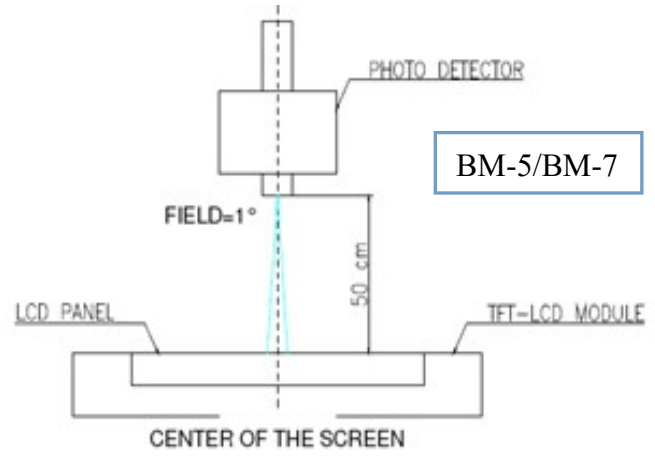
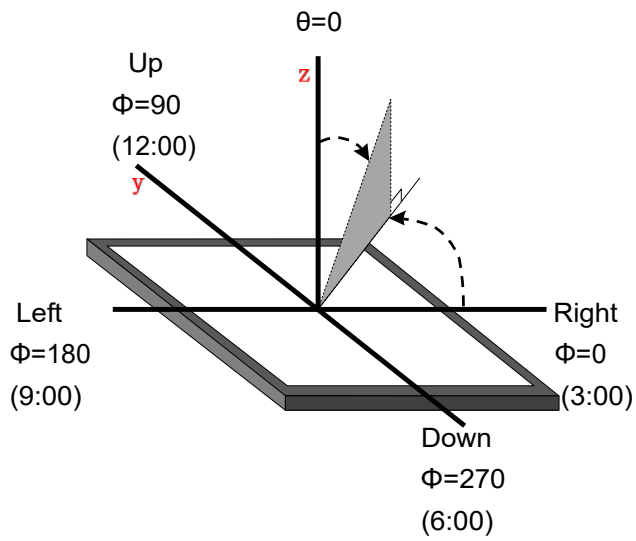

Figure c

FIG.3.The definition of viewing angle



8. Environmental / Reliability Tests

No	Test Item	Condition	Remarks
1	High Temperature Operation	Ts= +70°C, 96hrs	IEC60068-2-1:2007 GB2423. 2-2008
2	Low Temperature Operation	Ta= -20°C, 96hrs	IEC60068-2-1:2007 GB2423.1-2008
3	High Temperature Storage	Ta= +80°C,96hrs	IEC60068-2-1:2007 GB2423. 2-2008
4	Low Temperature Storage	Ta= -30°C, 96hrs	IEC60068-2-1:2007 GB2423.1-2008
5	High Temperature & Humidity Operation	Ta= +60°C, 90% RH max,96 hours	IIEC60068-2-78:2001 GB/T2423.3-2006
6	Thermal Shock (Non-operation)	-30°C 30 min ~ +80°C 30 min Change time: 5min, 20 Cycle	Start with cold temperature, end with high temperature IEC60068-2-14:1984, GB2423.22-2002
7	ESD	C=150pF, R=330 Ω, 5 points/panel , Air:±8KV, 5 times Contact: ±4KV, 5 times (Environment: 15°C ~ 35°C, 30% ~ 60%, 86Kpa ~ 106Kpa)	IEC61000-4-2:2001 GB/T17626.2-2006
8	Vibration (Non-operation)	Frequency range: 10~55Hz, Stroke: 1.5mm , Sweep: 10Hz~55Hz~10Hz 2 hours for each direction of X .Y. Z. (6 hours for total)	IEC60068-2-6:1982 GB/T2423.10-1995
9	Mechanical Shock (Non-operation)	Half Sine Wave 60G ,6ms,±X,±Y,±Z 3times for each direction	IEC60068-2-27:1987 GB/T2423.5—1995
10	Package Drop Test	Height: 60 cm, 1 corner, 3 edges, 6 surfaces	IEC60068-2-32:1990 GB/T2423.8-1995

Notes:

1. The test result shall be evaluated after the sample has been left at room temperature and humidity for 2 hours without load. No condensation shall be accepted. The sample will not be accepted if appear these defects:

- 1).Air bubble in the LCD;
- 2).Seal leak
- 3).Non-display
- 4).missing segments
- 5).Glass crack
- 6).CR reduction >40%
- 7).IDD increase >100%
- 8).Brightness reduction >50%
- 9).Color coordinate tolerance >0.05

2. ≤7.0 inch: The size of sample is 5pcs;

>7.0 inch: The size of sample is 2pcs;

3. One test sample must complete each test item;

4. In case of malfunction defect caused by ESD damage, if it would be recovered to normal state after resetting, it would be judge as a good part.

5. In the test of High Temperature Operation and High Temperature & Humidity Operation, the operation temperature is the surface temperature of module.

9. Mechanical Drawing

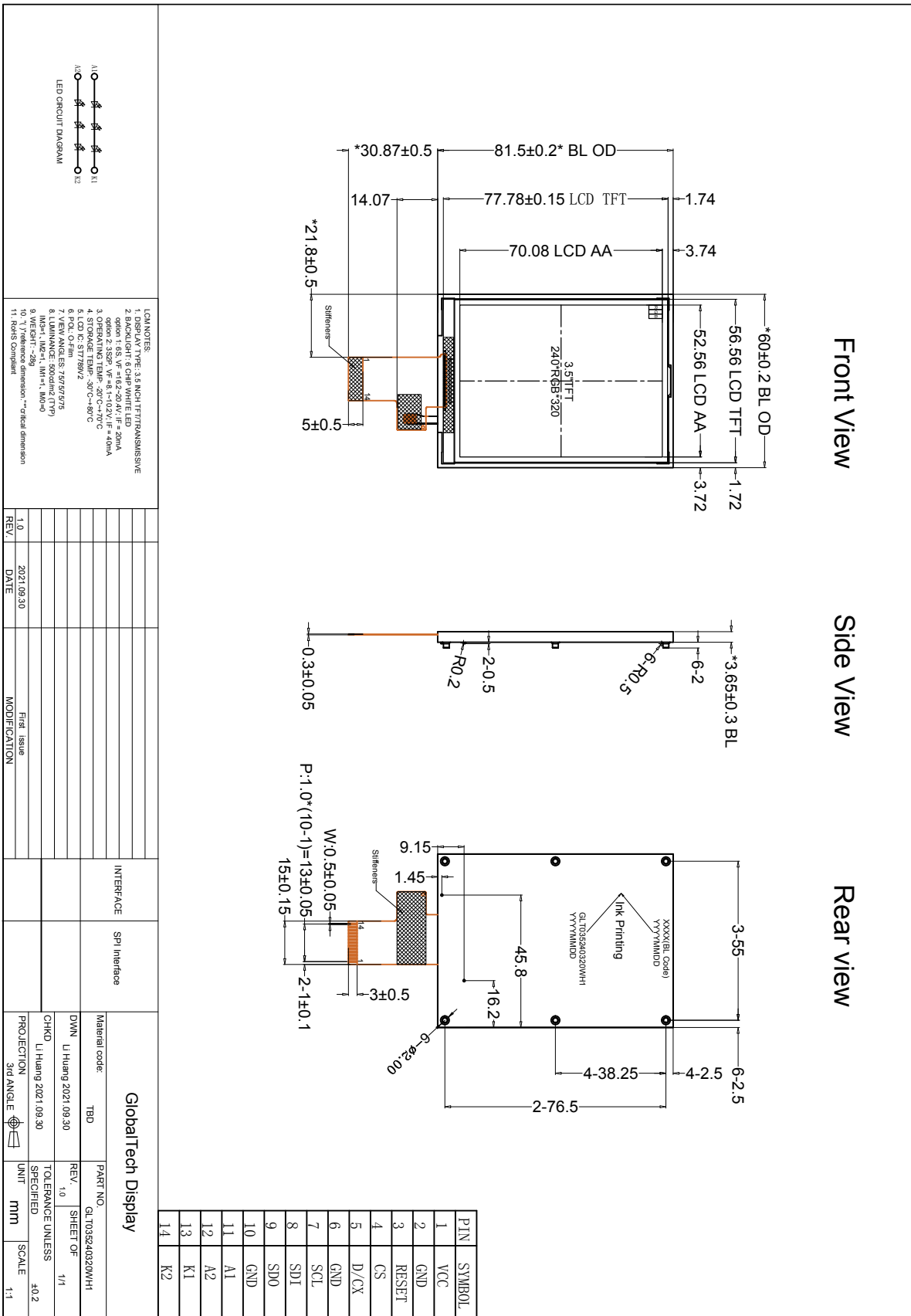

10. Packing

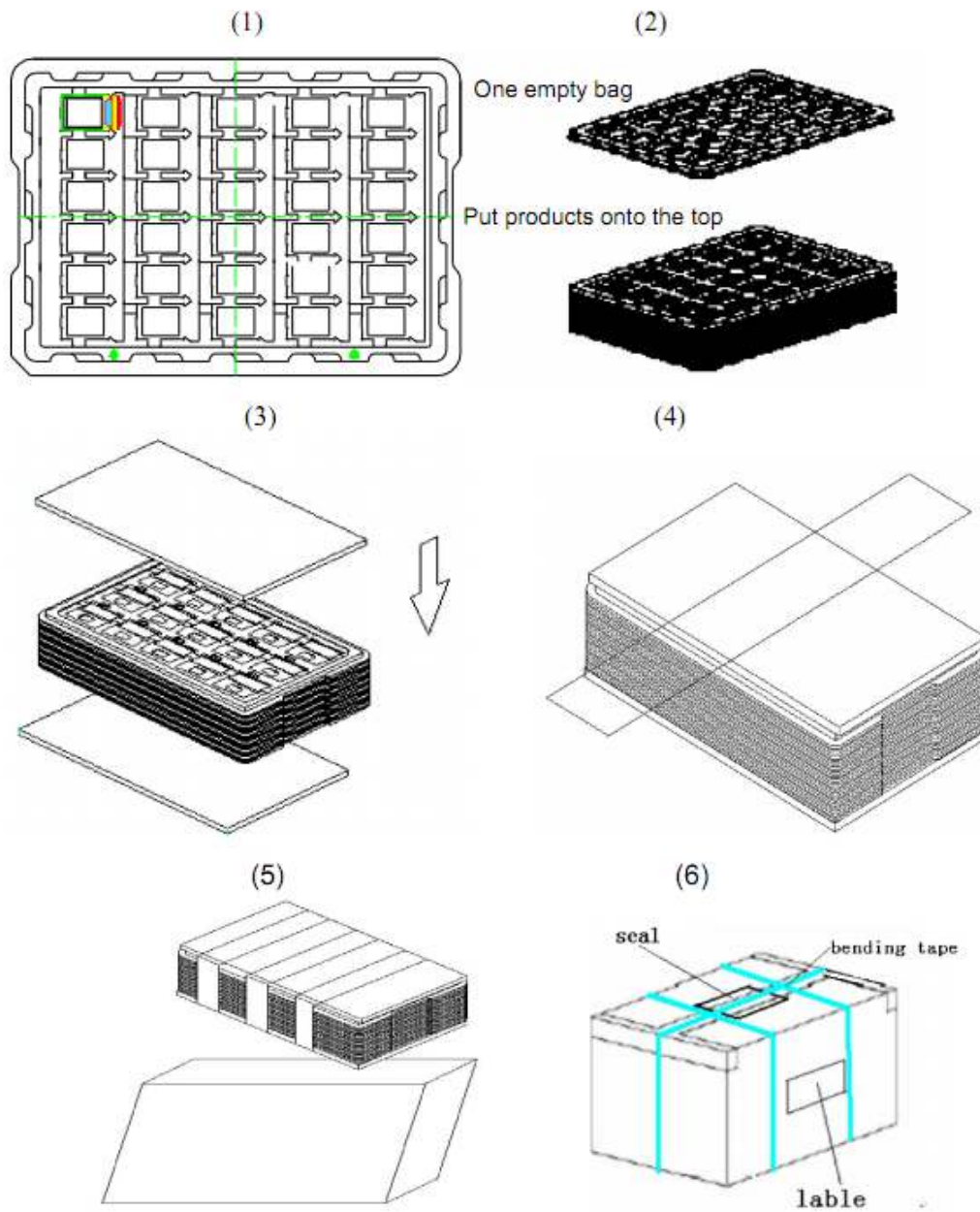

1. Put module into tray cavity
2. Tray stacking
3. Put 1 cardboard under the tray stack and 1 cardboard above
4. Fix the cardboard to the tray stack with adhesive tape
5. Put the tray stack into carton
6. Carton sealing with adhesive tape

11. TFT-LCD Module Inspection Criteria

11.1 Scope

The incoming inspection standards shall be applied to TFT-LCD Modules (hereinafter Called "Modules") that supplied by GlobalTech Display.

11.2 Incoming Inspection

The customer shall inspect the modules within twenty calendar days of the delivery date (the "inspection period) at its own cost. The result of the inspection (acceptance or rejection) shall be recorded in writing, and a copy of this writing will be promptly sent to the seller, If the results of the inspecting from buyer does not send to the seller within twenty calendar days of the delivery date. The modules shall be regards as acceptance. Should the customer fail to notify the seller within the inspection period, the buyer's right to reject the modules shall be lapsed and the modules shall be deemed to have been accepted by the buyer.

11.3 Inspection Sampling

11.3.1. Lot size: Quantity per shipment lot per model

11.3.2. Sampling type: Normal inspection, Single sampling

11.3.3. Inspection level: II

11.3.4. Sampling table: MIL-STD-105E

11.3.5. Acceptable quality level (AQL)

Major defect: AQL=0.65 Minor defect: AQL=1.00

11.4 Inspection Conditions

11.4.1 Ambient conditions:

a. Temperature: Room temperature $25\pm 5^{\circ}\text{C}$

b. Humidity: $(60\pm 10)\% \text{RH}$

c. Illumination: Single fluorescent lamp non-directive (300 to 700 Lux)

11.4.2 Viewing distance

The distance between the LCD and the inspector's eyes shall be at least $35\pm 5\text{cm}$.

11.4.3 Viewing Angle

U/D: $45^{\circ}/45^{\circ}$, L/R: $45^{\circ}/45^{\circ}$

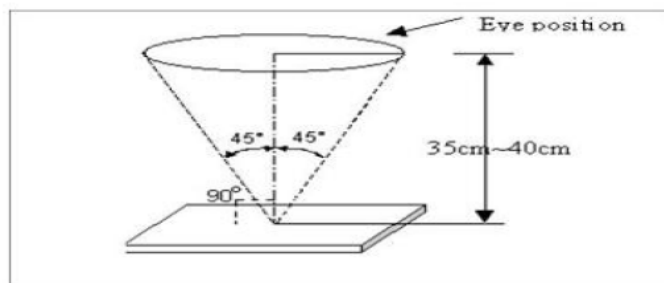

11.5 Inspection Criteria

Defects are classified as major defects and minor defects according to the degree of defectiveness defined herein.

11.5.1 Major defect

Item No	Items to be inspected	Inspection Standard
11.5.1.1	All functional defects	1) No display 2) Display abnormally 3) Short circuit 4) line defect
11.5.1.2	Missing	Missing function component
11.5.1.3	Crack	Glass Crack

11.5.2 Minor defect

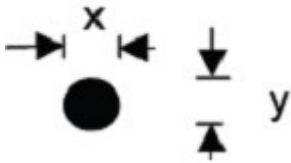
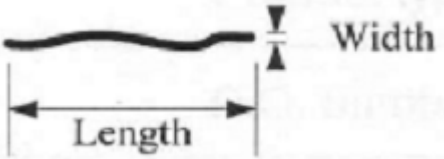
Item No	Items to be inspected	Inspection standard	
11.5.2.1	Spot Defect Including Black spot White spot Pinhole Foreign particle Polarizer dirt	For dark/white spot is defined $\varphi = (x+y) / 2$ 	
		Size φ (mm)	Acceptable Quantity
		$\varphi \leq 0.2$	Ignore
		$0.2 < \varphi \leq 0.3$	3
11.5.2.2	Line Defect Including Black line White line Scratch	Define: 	
		Width (mm) Length (mm)	Acceptable Quantity

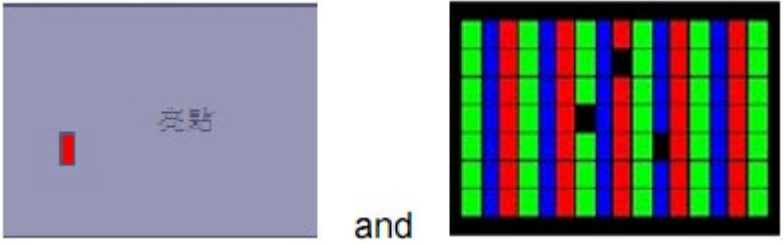
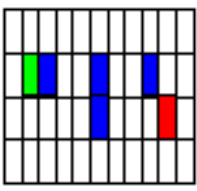
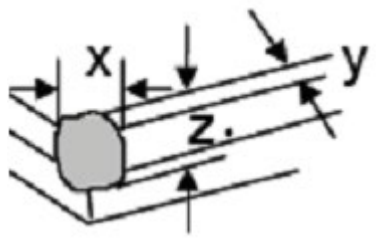
		$W \leq 0.05$	Ignore	
		$0.05 < W \leq 0.1$ $L \leq 2.5$	3	
		$0.1 < W$ or $L > 2.5$	Not allowed	
11.5.2.3	Polarizer Dent/Bubble	Size φ (mm)	Acceptable Quantity	
		$\varphi \leq 0.2$	Ignore	
		$0.2 < \varphi \leq 0.3$	2	
		$0.3 < \varphi \leq 0.3$	1	
		$0.3 < \varphi$	Not allowed	
		Total QTY	3	
11.5.2.4	Electrical Dot Defect	Bright and Black dot define:		
				
		and		
				
		Two Adjacent Dot		
		Inspection pattern: Full white, Full black, Red, green and blue screens		
		Item	Acceptable Quantity	
			I	O
		Black dot defect	2	(5mm ≤ Distance)
		Bright dot defect	1	
Two Adjacent Dot	1			
There or more Adjacent Dot	Not allowed			
Total Dot	2			
11.5.2.5	Glass defect			
		1. Corner Fragment:		

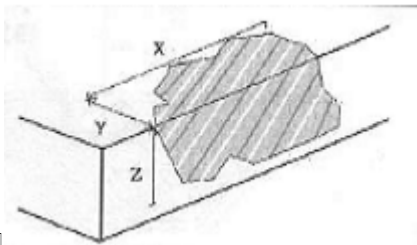
		Size (mm)	Acceptable Quantity □
		X≤3mm Y≤1mm Z≤T	Ignore T: Glass thickness X: Length Y: Width Z: thickness
			
		2. Side Fragment: □	
		Size(mm)	Acceptable Quantity
		X≤5.0mm Y≤1mm Z≤T	T: Glass thickness X: Length Y: Width Z: Thickness

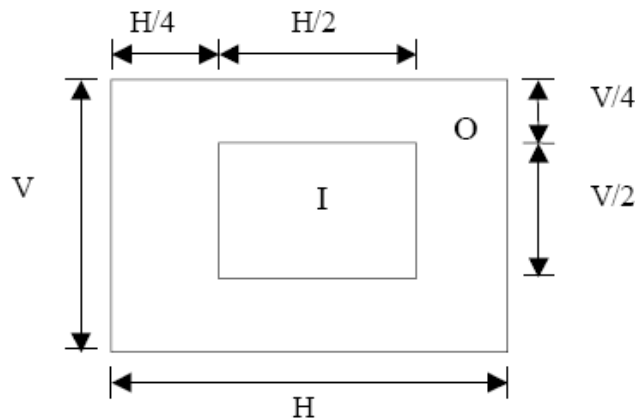

I area & O area

- Note:
- 1). Dot defect is defined as the defective area of the dot area is larger than 50% of the dot area.
 - 2). The distance between two bright dot defects (red, green, blue, and white) should be larger than 15mm.
 - 3). The distance between black dot defects or black and bright dot defects should be more than 5mm apart.
 - 4). Polarizer bubble is defined as the bubble appears on active display area. The defect of polarizer bubble shall be ignored if the polarizer bubble appears on the outside of active display area.

11.6 Mechanics specification

As for the outside dimension, weight of the modules, please refer to product specification
For more details

12. Precautions for Use of LCD modules

12.1 Handling Precautions

12.1.1. The display panel is made of glass. Do not subject it to a mechanical shock by dropping it from a high place, etc.

12.1.2. If the display panel is damaged and the liquid crystal substance inside it leaks out, be sure not to get any in your mouth, if the substance comes into contact with your skin or clothes, promptly wash it off using soap and water.

12.1.3. Do not apply excessive force to the display surface or the adjoining areas since this may cause the color tone to vary.

12.1.4. The polarizer covering the display surface of the LCD module is soft and easily scratched. Handle this polarizer carefully.

12.1.5. If the display surface is contaminated, breathe on the surface and gently wipe it with a soft dry cloth. If still not completely clear, moisten cloth with one of the following solvents:

- Isopropyl alcohol
- Ethyl alcohol

Solvents other than those mentioned above may damage the polarizer. Especially, do not use the following:

- Water
- Ketene

12.1.6. Do not attempt to disassemble the LCD Module.

12.1.7. If the logic circuit power is off, do not apply the input signals.

12.1.8. To prevent destruction of the elements by static electricity, be careful to maintain an optimum work environment.

12.1.8.1. Be sure to ground the body when handling the LCD Modules.

12.1.8.2. Tools required for assembly, such as soldering irons, must be properly ground.

12.1.8.3. To reduce the amount of static electricity generated, do not conduct assembly and other work under dry conditions.

12.1.8.4. The LCD Module is coated with a film to protect the display surface. Be care when peeling off this protective film since static electricity may be generated.

12.2 Storage Precautions

12.2.1. When storing the LCD modules, avoid exposure to direct sunlight or to the light of fluorescent lamps.

12.2.2. The LCD modules should be stored under the storage temperature range If the LCD modules

will be stored for a long time, the recommend condition is:

Temperature: 0°C ~ 40°C, Relatively humidity: ≤80%

12.2.3. The LCD modules should be stored in the room without acid, alkali and harmful gas.

12.3 Transportation Precautions

The LCD modules should be no falling and violent shocking during transportation, and also should avoid excessive press, water, damp and sunshine.