

Features

- Incorporates the ARM7TDMI® ARM® Thumb® Processor Core
 - High-performance 32-bit RISC Architecture
 - High-density 16-bit Instruction Set
 - Leader in MIPS/Watt
 - Embedded ICE (In-circuit Emulation)
- 256K Bytes of On-chip SRAM
 - 32-bit Data Bus, Single-clock Cycle Access
- 1024K Words 16-bit Flash Memory (2M bytes)
 - Single Voltage Read/Write,
 - Sector Erase Architecture
 - Dual-plane Organization Allows Concurrent Read and Program/Erase
 - Erase Suspend Capability
 - Low-power Operation
 - Data Polling, Toggle Bit and Ready/Busy End of Program Cycle Detection
 - Reset Input for Device Initialization
 - Sector Program Unlock Command
 - 128-bit Protection Register
 - Factory-programmed AT91 Flash Uploader Software
- Fully Programmable External Bus Interface (EBI)
 - Up to 8 Chip Selects, Maximum External Address Space of 64M Bytes
 - Software Programmable 8/16-bit External Data Bus
- 8-level Priority, Individually Maskable, Vectored Interrupt Controller
 - 4 External Interrupts, Including a High-priority Low-latency Interrupt Request
- 32 Programmable I/O Lines
- 3-channel 16-bit Timer/Counter
 - 3 External Clock Inputs, 2 Multi-purpose I/O Pins per Channel
- 2 USARTs
 - 2 Dedicated Peripheral Data Controller (PDC) Channels per USART
- Programmable Watchdog Timer
- Advanced Power-saving Features
 - CPU and Peripherals Can be De-activated Individually
- Fully Static Operation:
 - 0 Hz to 75 MHz Internal Frequency Range at VDDCORE = 1.8V, 85° C
- 2.7V to 3.6V I/O Operating Range, 1.65V to 1.95V Core Operating Range
- -40° C to 85° C Temperature Range
- Available in a 121-ball 10 x 10 x 1.2 mm BGA Package with 0.8 mm Ball Pitch

1. Description

The AT91FR40162 is a member of the Atmel AT91 16/32-bit Microcontroller family, which is based on the ARM7TDMI processor core. The processor has a high-performance 32-bit RISC architecture with a high-density 16-bit instruction set and very low power consumption.

The AT91FR40162 ARM microcontroller features 2 Mbits of on-chip SRAM and 2 Mbytes of Flash memory in a single compact 121-ball BGA package. Its high level of integration and very small footprint make the device ideal for space-constrained applications. The high-speed on-chip SRAM enables a performance of up to 74 MIPS in typical conditions with significant power reduction and EMC improvement over an external SRAM implementation.

The Flash memory may be programmed via the JTAG/ICE interface or the factory-programmed Flash Uploader using a single device supply, making the AT91FR40162 suitable for in-system programmable applications.



**AT91 ARM®
Thumb®
Microcontrollers**

AT91FR40162



2. Pin Configuration

Figure 2-1. AT91FR40162 Pinout for 121-ball BGA Package (Top View)

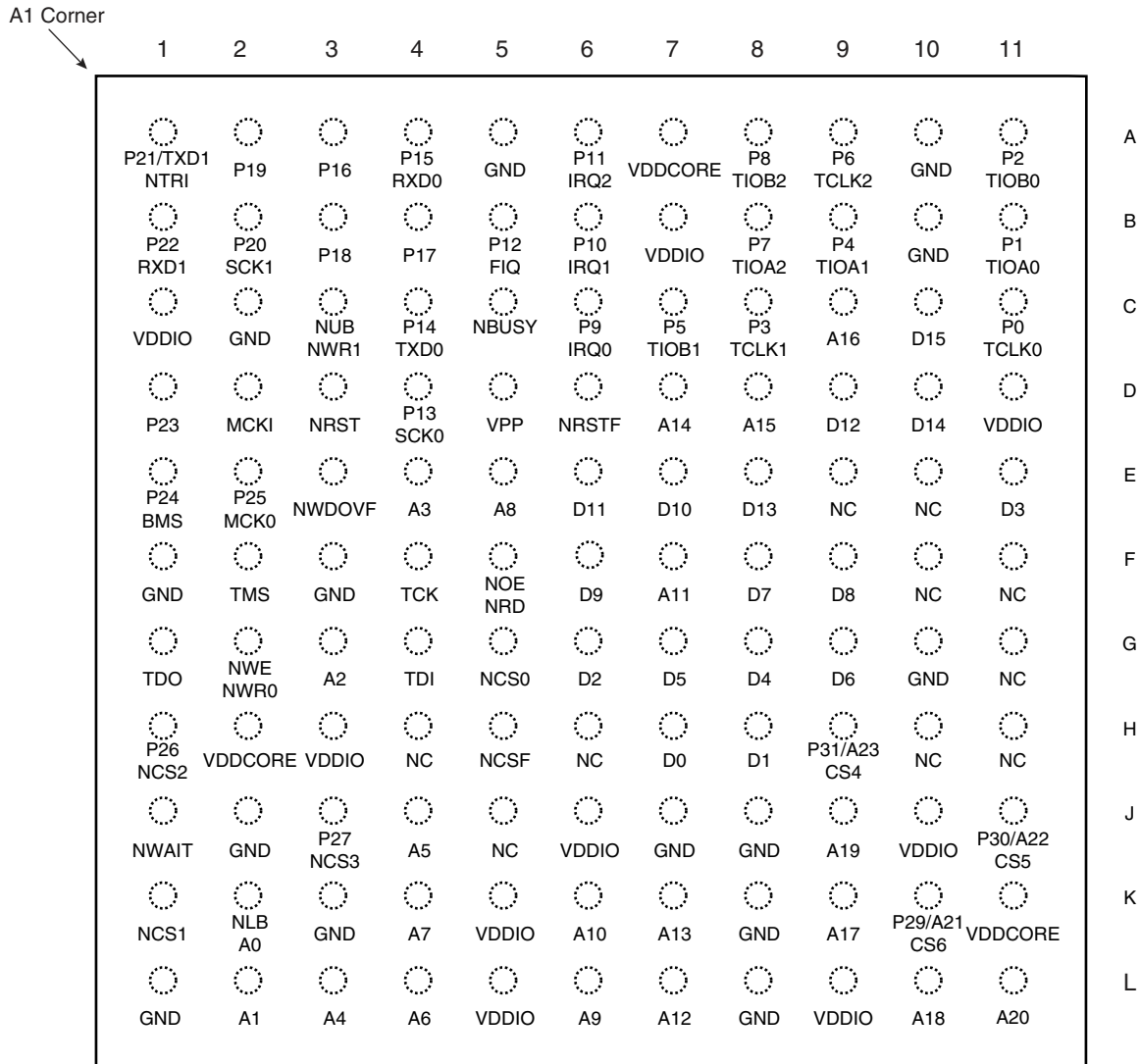

3. Pin Description

Table 3-1. AT91FR40162 Pin Description

Module	Name	Function	Type	Active Level	Comments
EBI	A0 - A23	Address Bus	Output	–	Valid after reset; do not reprogram A20 to I/O, as it is MSB of Flash address
	D0 - D15	Data Bus	I/O	–	
	NCS0 - NCS3	External Chip Select	Output	Low	Used to select external devices
	CS4 - CS7	External Chip Select	Output	High	A23 - A20 after reset
	NWR0	Lower Byte 0 Write Signal	Output	Low	Used in Byte Write option
	NWR1	Upper Byte 1 Write Signal	Output	Low	Used in Byte Write option
	NRD	Read Signal	Output	Low	Used in Byte Write option
	NWE	Write Enable	Output	Low	Used in Byte Select option
	NOE	Output Enable	Output	Low	Used in Byte Select option
	NUB	Upper Byte Select	Output	Low	Used in Byte Select option
	NLB	Lower Byte Select	Output	Low	Used in Byte Select option
	NWAIT	Wait Input	Input	Low	
	BMS	Boot Mode Select	Input	–	Sampled during reset; must be driven low during reset for Flash to be used as boot memory
AIC	FIQ	Fast Interrupt Request	Input	–	PIO-controlled after reset
	IRQ0 - IRQ2	External Interrupt Request	Input	–	PIO-controlled after reset
Timer	TCLK0 - TCLK2	Timer External Clock	Input	–	PIO-controlled after reset
	TIOA0 - TIOA2	Multi-purpose Timer I/O Pin A	I/O	–	PIO-controlled after reset
	TIOB0 - TIOB2	Multi-purpose Timer I/O Pin B	I/O	–	PIO-controlled after reset
USART	SCK0 - SCK1	External Serial Clock	I/O	–	PIO-controlled after reset
	TXD0 - TXD1	Transmit Data Output	Output	–	PIO-controlled after reset
	RXD0 - RXD1	Receive Data Input	Input	–	PIO-controlled after reset
PIO	P0 - P31	Parallel IO Line	I/O	–	
WD	NWDOVF	Watchdog Overflow	Output	Low	Open drain
Clock	MCKI	Master Clock Input	Input	–	Schmidt trigger
	MCKO	Master Clock Output	Output	–	
Reset	NRST	Hardware Reset Input	Input	Low	Schmidt trigger
	NTRI	Tri-state Mode Select	Input	Low	Sampled during reset
ICE	TMS	Test Mode Select	Input	–	Schmidt trigger, internal pull-up
	TDI	Test Data Input	Input	–	Schmidt trigger, internal pull-up
	TDO	Test Data Output	Output	–	
	TCK	Test Clock	Input	–	Schmidt trigger, internal pull-up

Table 3-1. AT91FR40162 Pin Description (Continued)

Module	Name	Function	Type	Active Level	Comments
Flash Memory	NCSF	Flash Memory Select	Input	Low	$\overline{\text{Enables}}$ Flash Memory when pulled low
	NBUSY	Flash Memory Busy Output	Output	Low	Flash RDY/ $\overline{\text{BUSY}}$ signal; open-drain
	NRSTF	Flash Memory Reset Input	Input	Low	Resets Flash to standard operating mode
Power	VDDIO	Power	Power	–	All V_{DDIO} , V_{DDCORE} and all GND pins MUST be connected to their respective supplies by the shortest route
	VDDCORE	Power	Power	–	
	GND	Ground	Ground	–	
	VPP ⁽¹⁾	Faster Program/Erase Voltage	Power	–	See AT49BV/LV1604A/1614A (T) 2-Mbyte (1M x 16/2M x 8) 3-volt Only Flash Memory Datasheet

Note: 1. To be compatible with AT91FR40162S, it is recommended to connect VPP to VDDIO. Please refer to the application note: How to Upgrade an AT91FR40162-based system to an AT91FR40162S-based System. [Atmel literature number 6186](#).

4. Block Diagram

Figure 4-1. AT91FR40162

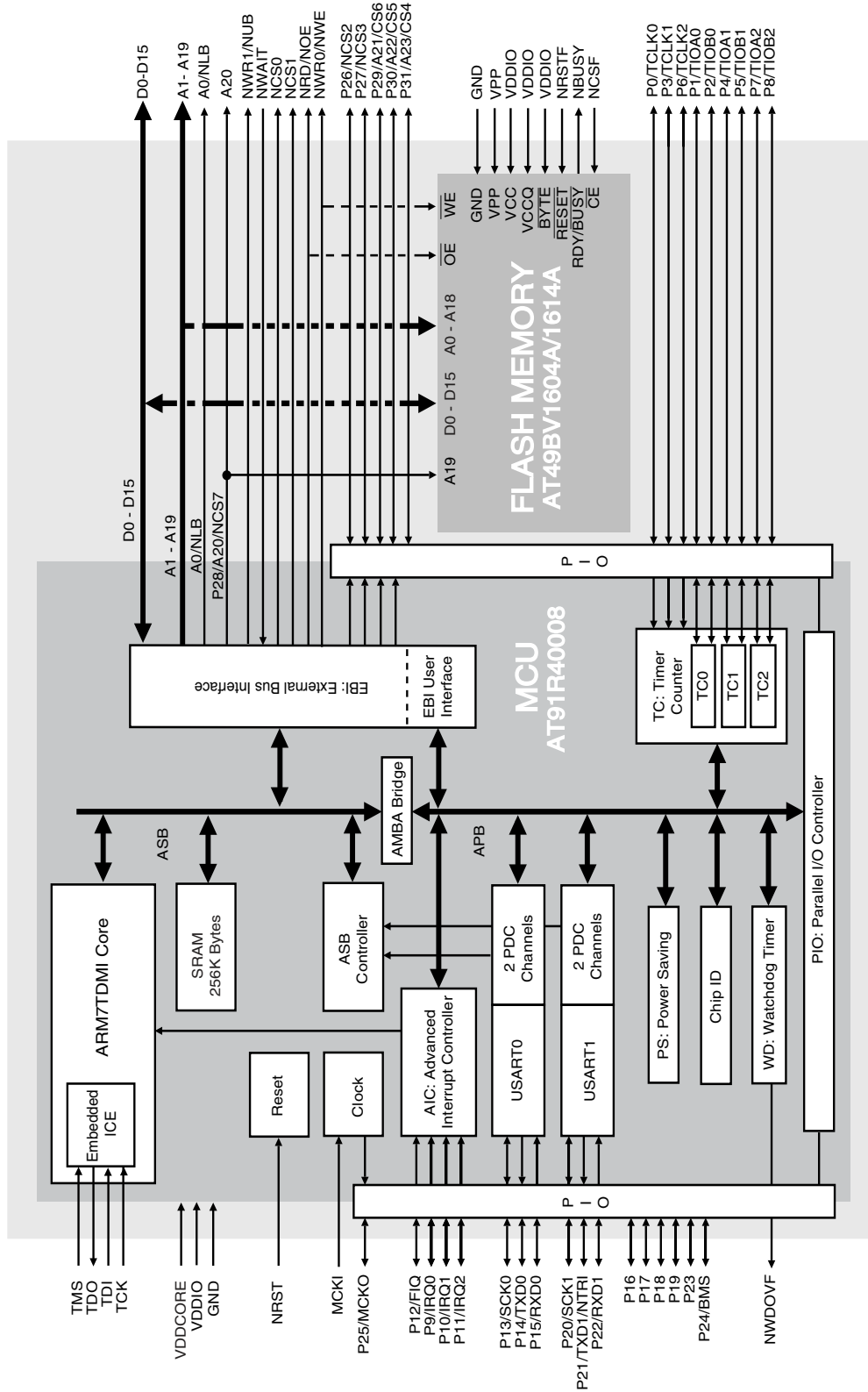

5. Architectural Overview

The AT91FR40162 integrates Atmel's AT91R40008 ARM Thumb processor and an AT49BV1604A/1614A 2-Mbyte (16-Mbit) Flash memory die in a single compact 121-ball BGA package. The address, data and control signals, except the Flash memory enable, are internally interconnected.

The AT91R40008 architecture consists of two main buses, the Advanced System Bus (ASB) and the Advanced Peripheral Bus (APB). Designed for maximum performance and controlled by the memory controller, the ASB interfaces the ARM7TDMI processor with the on-chip 32-bit SRAM memory, the External Bus Interface (EBI) connected to the encapsulated Flash and the AMBA™ Bridge. The AMBA Bridge drives the APB, which is designed for accesses to on-chip peripherals and optimized for low power consumption.

The AT91FR40162 implements the ICE port of the ARM7TDMI processor on dedicated pins, offering a complete, low-cost and easy-to-use debug solution for target debugging.

5.1 Memories

The AT91FR40162 embeds 256K bytes of internal SRAM. The internal memory is directly connected to the 32-bit data bus and is single-cycle accessible. This provides maximum performance of 67 MIPS at 75 MHz by using the ARM instruction set of the processor, minimizing system power consumption and improving on the performance of separate memory solutions.

The AT91FR40162 features an External Bus Interface (EBI), which enables connection of external memories and application-specific peripherals. The EBI supports 8- or 16-bit devices and can use two 8-bit devices to emulate a single 16-bit device. The EBI implements the early read protocol, enabling faster memory accesses than standard memory interfaces.

The AT91FR40162 encapsulates a Flash memory organized as 1024K 16-bit words, accessed via the EBI. A 16-bit Thumb instruction can be loaded from Flash memory in a single access. Separate MCU and Flash memory reset inputs (NRST and NRSTF) are provided for maximum flexibility. The user is thus free to tailor the reset operation to the application.

The AT91FR40162 integrates resident boot software called AT91 Flash Uploader software in the encapsulated Flash. The AT91 Flash Uploader software is able to upload program application software into its Flash memory.

5.2 Peripherals

The AT91FR40162 integrates several peripherals, which are classified as system or user peripherals.

All on-chip peripherals are 32-bit accessible by the AMBA Bridge, and can be programmed with a minimum number of instructions. The peripheral register set is composed of control, mode, data, status and enable/disable/status registers.

An on-chip Peripheral Data Controller (PDC) transfers data between the on-chip USARTs and on- and off-chip memory address space without processor intervention. Most importantly, the PDC removes the processor interrupt handling overhead, making it possible to transfer up to 64K contiguous bytes without reprogramming the start address, thus increasing the performance of the microcontroller, and reducing the power consumption.

5.2.1 System Peripherals

The External Bus Interface (EBI) controls the external memory or peripheral devices via an 8- or 16-bit databus and is programmed through the APB. Each chip select line has its own programming register.

The Power-saving (PS) module implements the Idle Mode (ARM7TDMI core clock stopped until the next interrupt) and enables the user to adapt the power consumption of the microcontroller to application requirements (independent peripheral clock control).

The Advanced Interrupt Controller (AIC) controls the internal interrupt sources from the internal peripherals and the four external interrupt lines (including the FIQ) to provide an interrupt and/or fast interrupt request to the ARM7TDMI. It integrates an 8-level priority controller, and, using the Auto-vectoring feature, reduces the interrupt latency time.

The Parallel Input/Output Controller (PIO) controls up to 32 I/O lines. It enables the user to select specific pins for on-chip peripheral input/output functions, and general-purpose input/output signal pins. The PIO controller can be programmed to detect an interrupt on a signal change from each line.

The Watchdog (WD) can be used to prevent system lock-up if the software becomes trapped in a deadlock.

The Special Function (SF) module integrates the Chip ID, the Reset Status and the Protect registers.

5.2.2 User Peripherals

Two USARTs, independently configurable, enable communication at a high baud rate in synchronous or asynchronous mode. The format includes start, stop and parity bits and up to 8 data bits. Each USART also features a Timeout and a Time Guard register, facilitating the use of the two dedicated Peripheral Data Controller (PDC) channels.

The 3-channel, 16-bit Timer Counter (TC) is highly programmable and supports capture or waveform modes. Each TC channel can be programmed to measure or generate different kinds of waves, and can detect and control two input/output signals. The TC has also 3 external clock signals.

6. Associated Documentation

Associated Documentation

Product	Information	Document Title	
AT91FR40162	Internal architecture of processor ARM/Thumb instruction sets Embedded in-circuit emulator	ARM7TDMI (Thumb) Datasheet	
	External memory interface mapping Peripheral operations Peripheral user interfaces	AT91x40 Series Datasheet	
	DC characteristics Power consumption Thermal and reliability considerations AC characteristics	MCU	AT91R40008 Electrical Characteristics Datasheet
		Flash Memory	AT49BV/LV1604A/1614A(T) 2-Mbyte (1M x 16/2M x 8) 3-volt Only Flash Memory Datasheet
	Product overview Ordering information Packaging information Soldering profile	AT91FR40162 Datasheet (this document)	
	Detailed description of Flash memory	AT49BV/LV1604A/1614A(T) 2-Mbyte (1M x 16/2M x 8) 3-volt Only Flash Memory Datasheet	

7. Product Overview

7.1 Power Supply

The AT91FR40162 device has two types of power supply pins:

- VDDCORE pins that power the chip core (i.e., the AT91R40008 with its embedded SRAM and peripherals)
- VDDIO pins that power the AT91R40008 I/O lines and the Flash memory

An independent I/O supply allows a flexible adaptation to external component signal levels.

7.2 Input/Output Considerations

The AT91FR40162 I/O pads accept voltage levels up to the VDDIO power supply limit. After the reset, the microcontroller peripheral I/Os are initialized as inputs to provide the user with maximum flexibility. It is recommended that in any application phase, the inputs to the microcontroller be held at valid logic levels to minimize the power consumption.

7.3 Master Clock

The AT91FR40162 has a fully static design and works on the Master Clock (MCK), provided on the MCKI pin from an external source.

The Master Clock is also provided as an output of the device on the pin MCKO, which is multiplexed with a general purpose I/O line. While NRST is active, and after the reset, the MCKO is valid and outputs an image of the MCK signal. The PIO Controller must be programmed to use this pin as standard I/O line.

7.4 Reset

Reset restores the default states of the user interface registers (defined in the user interface of each peripheral), and forces the ARM7TDMI to perform the next instruction fetch from address zero. Except for the program counter the ARM7TDMI registers do not have defined reset states.

7.4.1 NRST Pin

NRST is active low-level input. It is asserted asynchronously, but exit from reset is synchronized internally to the MCK. The signal presented on MCKI must be active within the specification for a minimum of 10 clock cycles up to the rising edge of NRST to ensure correct operation. The first processor fetch occurs 80 clock cycles after the rising edge of NRST.

7.4.2 Watchdog Reset

The watchdog can be programmed to generate an internal reset. In this case, the reset has the same effect as the NRST pin assertion, but the pins BMS and NTRI are not sampled. Boot Mode and Tri-state Mode are not updated. If the NRST pin is asserted and the watchdog triggers the internal reset, the NRST pin has priority.

7.5 Emulation Functions

7.5.1 Tri-state Mode

The AT91FR40162 microcontroller provides a tri-state mode, which is used for debug purposes. This enables the connection of an emulator probe to an application board without

having to desolder the device from the target board. In tri-state mode, all the output pin drivers of the AT91FR40008 microcontroller are disabled.

In tri-state mode, direct access to the Flash via external pins is provided. This enables production Flash programming using classical Flash programmers prior to board mounting.

To enter tri-state mode, the NTRI pin must be held low during the last 10 clock cycles before the rising edge of NRST. For normal operation, the NTRI pin must be held high during reset by a resistor of up to 400 k Ω .

NTRI is multiplexed with I/O line P21 and USART1 serial data transmit line TXD1.

7.5.2 JTAG/ICE Debug

ARM-standard embedded In-circuit Emulation is supported via the JTAG/ICE port. The pins TDI, TDO, TCK and TMS are dedicated to this debug function and can be connected to a host computer via the external ICE interface. In ICE Debug Mode, the ARM7TDMI core responds with a non-JTAG chip ID that identifies the microcontroller. This is not fully IEEE1149.1 compliant.

7.6 Memory Controller

The ARM7TDMI processor address space is 4G bytes. The memory controller decodes the internal 32-bit address bus and defines three address spaces:

- Internal memories in the four lowest megabytes
- Middle space reserved for the external devices (memory or peripherals) controlled by the EBI
- Internal peripherals in the four highest megabytes

In any of these address spaces, the ARM7TDMI operates in little-endian mode only.

7.6.1 Internal Memories

The AT91FR40162 microcontroller integrates 256K bytes of internal SRAM. It is 32 bits wide and single-clock cycle accessible. Byte (8-bit), half-word (16-bit) and word (32-bit) accesses are supported and are executed within one cycle. Fetching either Thumb or ARM instructions is supported, and internal memory can store two times as many Thumb instructions as ARM instructions.

The SRAM is mapped at address 0x0 (after the Remap command), allowing ARM7TDMI exception vectors between 0x0 and 0x20 to be modified by the software.

Placing the SRAM on-chip and using the 32-bit data bus bandwidth maximizes the microcontroller performance and minimizes system power consumption. The 32-bit bus increases the effectiveness of the use of the ARM instruction set and the processing of data that is wider than 16 bits, thus making optimal use of the ARM7TDMI advanced performance.

Being able to dynamically update application software in the 256-Kbyte SRAM adds an extra dimension to the AT91FR40162.

The AT91FR40162 also integrates a 2-Mbyte Flash memory that is accessed via the External Bus Interface. All data, address and control lines, except for the Chip Select signal, are connected within the device.

7.6.2 Boot Mode Select

The ARM reset vector is at address 0x0. After the NRST line is released, the ARM7TDMI executes the instruction stored at this address. This means that this address must be mapped in nonvolatile memory after the reset. The input level on the BMS pin during the last 10 clock cycles before the rising edge of the NRST selects the type of boot memory (see Table 1).

If the embedded Flash memory is to be used as boot memory, the BMS input must be pulled down externally and NCS0 must be connected to NCSF externally.

The pin BMS is multiplexed with the I/O line P24 that can be programmed after reset like any standard PIO line.

Table 1. Boot Mode Select

BMS	Boot Memory
1	External 8-bit memory on NCS0
0	External 16-bit memory on NCS0

7.6.3 Remap Command

The ARM vectors (Reset, Abort, Data Abort, Prefetch Abort, Undefined Instruction, Interrupt, Fast Interrupt) are mapped from address 0x0 to address 0x20. In order to allow these vectors to be redefined dynamically by the software, the AT91FR40162 uses a remap command that enables switching between the boot memory and the internal primary SRAM bank addresses. The remap command is accessible through the EBI User Interface by writing one in RCB of EBI_RCR (Remap Control Register). Performing a remap command is mandatory if access to the other external devices (connected to chip selects 1 to 7) is required. The remap operation can only be changed back by an internal reset or an NRST assertion.

7.6.4 Abort Control

The abort signal providing a Data Abort or a Prefetch Abort exception to the ARM7TDMI is asserted when accessing an undefined address in the EBI address space.

No abort is generated when reading the internal memory or by accessing the internal peripherals, whether the address is defined or not.

7.6.5 External Bus Interface

The External Bus Interface handles the accesses between addresses 0x0040 0000 and 0xFFC0 0000. It generates the signals that control access to the external devices, and can be configured from eight 1-Mbyte banks up to four 16-Mbyte banks. It supports byte, half-word and word aligned accesses.

For each of these banks, the user can program:

- Number of wait states
- Number of data float times (wait time after the access is finished to prevent any bus contention in case the device is too long in releasing the bus)
- Data bus width (8-bit or 16-bit)
- With a 16-bit wide data bus, the user can program the EBI to control one 16-bit device (Byte Access Select Mode) or two 8-bit devices in parallel that emulate a 16-bit memory (Byte Write Access Mode).



The External Bus Interface features also the Early Read Protocol, configurable for all the devices, that significantly reduces access time requirements on an external device in the case of single-clock cycle access.

In the AT91FR40162, the External Bus Interface connects internally to the Flash memory.

7.6.6 Flash Memory

The 2-Mbyte Flash memory is organized as 1, 048, 576 words of 16 bits each. The Flash memory is addressed as 16-bit words via the EBI. It uses address lines A1 - A20.

The address, data and control signals, except the Flash memory enable, are internally interconnected. The user should connect the Flash memory enable (NCSF) to one of the active-low chip selects on the EBI; NCS0 must be used if the Flash memory is to be the boot memory. In addition, if the Flash memory is to be used as boot memory, the BMS input must be pulled down externally in order for the processor to perform correct 16-bit fetches after reset.

During boot, the EBI must be configured with correct number of standard wait states. As an example, five standard wait states are required when the microcontroller is running at 66 MHz.

The user must ensure that all VDDIO, VDDCORE and all GND pins are connected to their respective supplies by the shortest route. The Flash memory powers-on in read mode. Command sequences are used to place the device in other operating modes, such as program and erase.

A separate Flash memory reset input pin (NRSTF) is provided for maximum flexibility, enabling the reset operation to adapt to the application. When this input is at a logic high level, the memory is in its standard operating mode; a low level on this input halts the current memory operation and puts its outputs in a high impedance state.

The Flash memory features data polling to detect the end of a program cycle. While a program cycle is in progress, an attempted read of the last word written will return the complement of the written data on I/O7. An open-drain NBUSY output pin provides another method of detecting the end of a program or erase cycle. This pin is pulled low while program and erase cycles are in progress and is released at the completion of the cycle. A toggle bit feature provides a third means of detecting the end of a program or erase cycle.

The Flash memory is segmented into two memory planes. Reads from one memory plane may be performed even while program or erase functions are being executed in the other memory plane. This feature enhances performance by not requiring the system to wait for a program or erase cycle to complete before a read may be performed.

The Flash memory is divided into 39 sectors for erase operations. To further enhance device flexibility, an Erase Suspend feature is offered. This feature puts the erase cycle on hold for an indefinite period and allows the user to read data from, or to write data to, any other sector within the same memory plane. There is no need to suspend an erase cycle if the data to be read is in the other memory plane.

The device has the capability to protect data stored in any sector. Once the data protection for a sector is enabled, the data in that sector cannot be changed while input levels lie between ground and VDDIO.

An optional VPP pin is available to enhance program/erase times.

A 6-byte command sequence (Enter Single Pulse Program Mode) allows the device to be written to directly, using single pulses on the write control lines. This mode (Single-pulse

Programming) is exited by powering down the device or by pulsing the NRSTF pin low for a defined duration⁽¹⁾ and then bringing it back to VDDIO.

The following hardware features protect against inadvertent programming of the Flash memory:

- VDDIO Sense – if VDDIO is below a certain level⁽¹⁾, the program function is inhibited.
- VDDIO Power-on Delay – once VDDIO has reached the VDDIO sense level, the device will automatically time out a certain duration⁽¹⁾ before programming.
- Program Inhibit – holding any one of OE low, CE high or WE high inhibits program cycles.
- Noise Filter – pulses of less than a certain duration⁽¹⁾ on the WE or CE inputs will not initiate a program cycle.

See the AT49BV1604A/1614A(T) 2-Mbyte (1M x 16/2M x 8) 3-volt Only Flash Memory Datasheet for further details on Flash operation and electrical characteristics.

Note: 1. Defined in the AT49BV1614A Flash Memory Datasheet, Atmel lit^o 1411.

7.7 AT91 Flash Uploader Software

All Flash-based AT91 devices are delivered with a pre-programmed software called the AT91 Flash Uploader, which resides in the first sector of the embedded Flash. The Flash Uploader allows programming to the embedded flash through a serial port. Either of the on-chip USARTs can be used by the Flash Uploader.

Figure 7-1. Flash Uploader

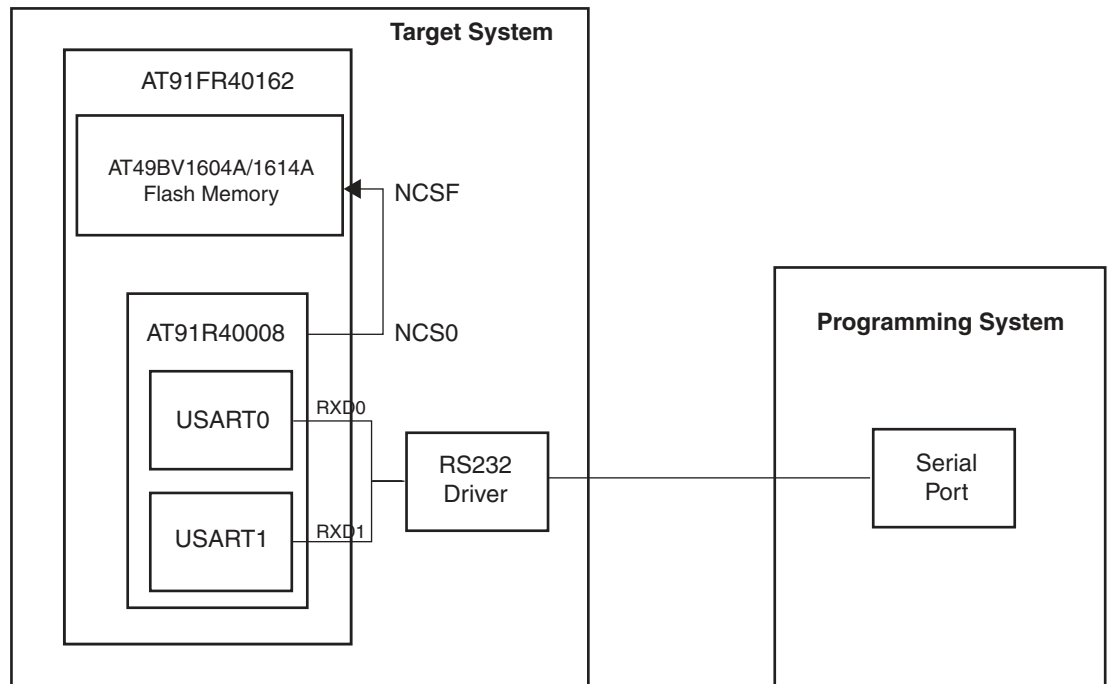

7.7.1 Flash Uploader Operations

The Flash Uploader requires the encapsulated Flash to be used as the AT91FR40162 boot memory and a valid clock to be applied to MCKI. After reset, the Flash Uploader immediately recopies itself into the internal SRAM and jumps to it. The following operation requires this



memory resource only. External accesses are performed only to program the encapsulated Flash.

When starting, PIO input change interrupts are initialized on the RXD lines of both USARTs. When an interrupt occurs, a Timer Counter channel is started. When the next input change is detected on the RXD line, the Timer Counter channel is stopped. This is how the first character length is measured and the USART can be initiated by taking into account the ratio between the device master clock speed and the actual communication baud rate speed.

The Programming System, then, can send commands and data following a proprietary protocol for the Flash device to be programmed. It is up to the Programming System to erase and program the first sector of the Flash as the last step of the operation, in order to reduce, to a minimum, the risk that the Flash Uploader is erased and the power supply shuts down.

Note that in the event that the Flash Uploader is erased from the first sector while the new final application is not yet programmed, and while the target system power supply is switched off, it leads to a non-recoverable error and the AT91FR40162 cannot be re-programmed by using the Flash Uploader.

7.7.2 Programming System

Atmel provides a free Host Loader that runs on an IBM® compatible PC under Windows®95 or Windows®98 operating system. It can be downloaded from the Atmel Web site and requires only a serial cable to connect the Host to the Target.

Communications can be selected on either COM1 or COM2 and the serial link speed is limited to 115200 bauds. Because the serial link is the bottleneck in this configuration, the Flash programming lasts 110 seconds per Mbyte.

Reduced programming time can be achieved by using a faster programming system. An AT91 Evaluation Board is capable of running a serial link at up to 500 Kbits/sec and can match the fastest programming allowed by the Flash, for example, about 40 seconds per Mbyte when the word programming becomes the bottleneck.

7.8 Peripherals

The AT91FR40162 peripherals are connected to the 32-bit wide Advanced Peripheral Bus.

Peripheral registers are only word accessible. Byte and half-word accesses are not supported. If a byte or a half-word access is attempted, the memory controller automatically masks the lowest address bits and generates a word access.

Each peripheral has a 16-Kbyte address space allocated (the AIC only has a 4-Kbyte address space).

7.8.1 Peripheral Registers

The following registers are common to all peripherals:

- Control Register – write only register that triggers a command when a one is written to the corresponding position at the appropriate address. Writing a zero has no effect.
- Mode Register – read/write register that defines the configuration of the peripheral. Usually has a value of 0x0 after a reset.
- Data Registers – read and/or write register that enables the exchange of data between the processor and the peripheral.
- Status Register – read only register that returns the status of the peripheral.

- Enable/Disable/Status Registers are shadow command registers. Writing a one in the Enable Register sets the corresponding bit in the Status Register. Writing a one in the Disable Register resets the corresponding bit and the result can be read in the Status Register. Writing a bit to zero has no effect. This register access method maximizes the efficiency of bit manipulation, and enables modification of a register with a single non-interruptible instruction, replacing the costly read-modify-write operation.

Unused bits in the peripheral registers must be written at 0 for upward compatibility. These bits read 0.

7.8.2 Peripheral Interrupt Control

The Interrupt Control of each peripheral is controlled from the status register using the interrupt mask. The status register bits are ANDed to their corresponding interrupt mask bits and the result is then ORed to generate the Interrupt Source signal to the Advanced Interrupt Controller.

The interrupt mask is read in the Interrupt Mask Register and is modified with the Interrupt Enable Register and the Interrupt Disable Register. The enable/disable/status (or mask) makes it possible to enable or disable peripheral interrupt sources with a non-interruptible single instruction. This eliminates the need for interrupt masking at the AIC or Core level in real-time and multi-tasking systems.

7.8.3 Peripheral Data Controller

The AT91FR40162 has a 4-channel PDC dedicated to the two on-chip USARTs. One PDC channel is dedicated to the receiver and one to the transmitter of each USART.

The user interface of a PDC channel is integrated in the memory space of each USART. It contains a 32-bit Address Pointer Register (RPR or TPR) and a 16-bit Transfer Counter Register (RCR or TCR). When the programmed number of transfers are performed, a status bit indicating the end of transfer is set in the USART Status Register and an interrupt can be generated.

7.9 System Peripherals

7.9.1 PS: Power-saving

The power-saving feature optimizes power consumption, enabling the software to stop the ARM7TDMI clock (idle mode), restarting it when the module receives an interrupt (or reset). It also enables on-chip peripheral clocks to be enabled and disabled individually, matching power consumption and application needs.

7.9.2 AIC: Advanced Interrupt Controller

The Advanced Interrupt Controller has an 8-level priority, individually maskable, vectored interrupt controller, and drives the NIRQ and NFIQ pins of the ARM7TDMI from:

- The external fast interrupt line (FIQ)
- The three external interrupt request lines (IRQ0 - IRQ2)
- The interrupt signals from the on-chip peripherals

The AIC is extensively programmable offering maximum flexibility, and its vectoring features reduce the real-time overhead in handling interrupts.

The AIC also features a spurious vector detection feature, which reduces spurious interrupt handling to a minimum, and a protect mode that facilitates the debug capabilities.

7.9.3 PIO: Parallel I/O Controller

The AT91FR40162 has 32 programmable I/O lines. Six pins are dedicated as general-purpose I/O pins. Other I/O lines are multiplexed with an external signal of a peripheral to optimize the use of available package pins. The PIO controller enables generation of an interrupt on input change and insertion of a simple input glitch filter on any of the PIO pins.

7.9.4 WD: Watchdog

The Watchdog is built around a 16-bit counter and is used to prevent system lock-up if the software becomes trapped in a deadlock. It can generate an internal reset or interrupt, or assert an active level on the dedicated pin NWDOVF. All programming registers are password-protected to prevent unintentional programming.

7.9.5 SF: Special Function

The AT91FR40162 provides registers that implement the following special functions.

- Chip Identification
- RESET Status
- Protect Mode

7.10 User Peripherals

7.10.1 USART: Universal Synchronous/Asynchronous Receiver Transmitter

The AT91FR40162 provides two identical, full-duplex, universal synchronous/asynchronous receiver/transmitters.

Each USART has its own baud rate generator, and two dedicated Peripheral Data Controller channels. The data format includes a start bit, up to 8 data bits, an optional programmable parity bit and up to 2 stop bits.

The USART also features a Receiver Timeout register, facilitating variable length frame support when it is working with the PDC, and a Time-guard register, used when interfacing with slow remote equipment.

7.10.2 TC: Timer Counter

The AT91FR40162 features a Timer Counter block that includes three identical 16-bit timer counter channels. Each channel can be independently programmed to perform a wide range of functions including frequency measurement, event counting, interval measurement, pulse generation, delay timing and pulse width modulation.

The Timer Counter can be used in Capture or Waveform mode, and all three counter channels can be started simultaneously and chained together.

8. Ordering Information

Table 8-1. Ordering Information

Ordering Code	Package	Temperature Operating Range
AT91FR40162-CI	BGA 121	Industrial (-40° C to 85° C)

9. Packaging Information

Figure 9-1. AT91FR40162 Package

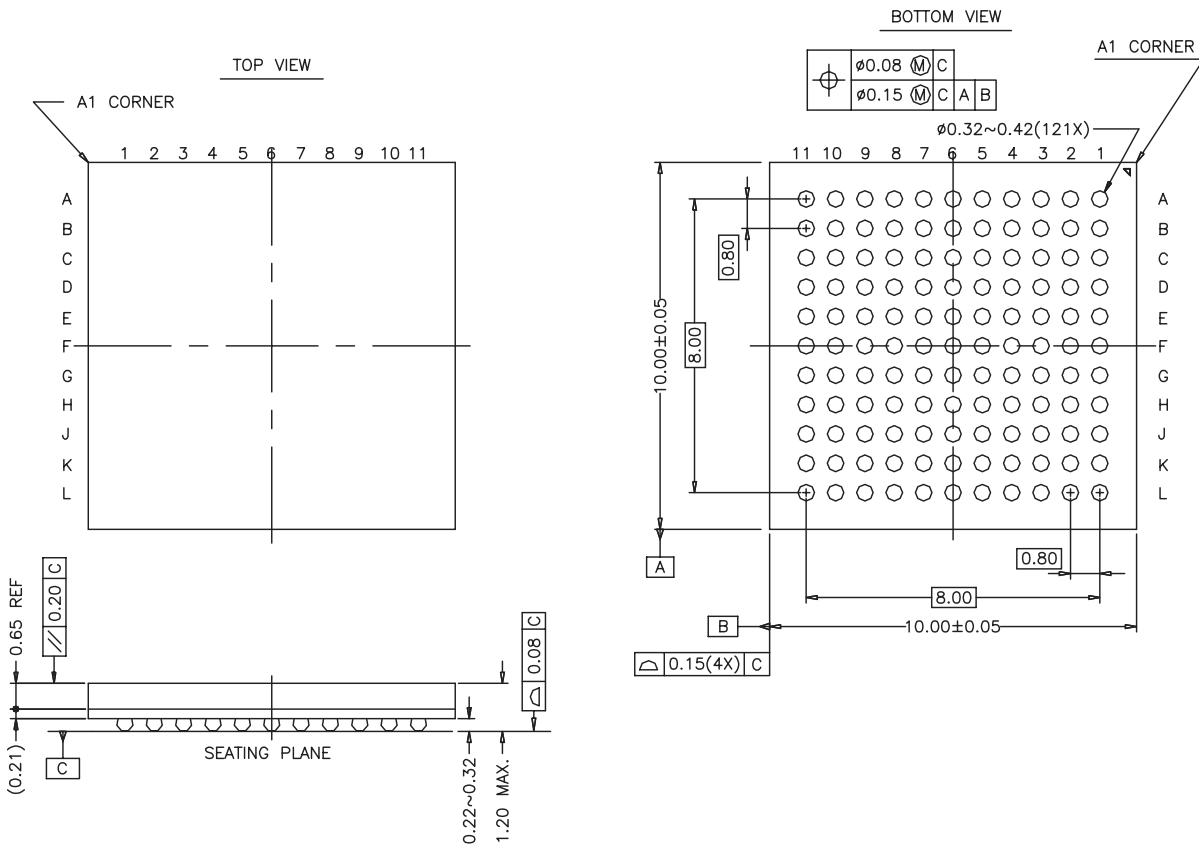

Table 9-1. Thermal Resistance Data

Symbol	Parameter	Condition	Package	Typ	Units
θ_{JA}	Junction-to-ambient thermal resistance	Still Air	121-BGA	33.9	°C/W
θ_{JC}	Junction-to-case thermal resistance		121-BGA	7.7	

Table 9-2. Device and 121-ball BGA Package Maximum Weight

194	mg
-----	----

Table 9-3. 121-ball BGA Package Characteristics

Ball diameter	0.35 mm
Ball land	0.4 ± 0.05 mm
Solder mask opening	0.3 ± 0.05 mm
Plating material	Copper
Solder ball material	Sn/Pb
Moisture Sensitivity Level	3

10. Soldering Profile

Table 10-1 gives the recommended soldering profile from J-STD-20.

Table 10-1. Soldering Profile

	Convection or IR/Convection	VPR
Average Ramp-up Rate (183° C to Peak)	3° C/sec. max.	10° C/sec.
Preheat Temperature 125° C ±25° C	120 sec. max	
Temperature Maintained Above 183° C	60 sec. to 150 sec.	
Time within 5° C of Actual Peak Temperature	10 sec. to 20 sec.	60 sec.
Peak Temperature Range	220 +5/-0° C or 235 +5/-0° C	215 to 219° C or 235 +5/-0° C
Ramp-down Rate	6° C/sec.	10° C/sec.
Time 25° C to Peak Temperature	6 min. max	

Small packages may be subject to higher temperatures if they are reflowed in boards with larger components. In this case, small packages may have to withstand temperatures of up to 235° C, not 220° C (IR reflow).

Recommended package reflow conditions depend on package thickness and volume. See Table 10-2.

Table 10-2. Recommended Package Reflow Conditions ^(1, 2, 3)

Parameter	Temperature
Convection	220 +5/-0° C
VPR	215 to 219° C
IR/Convection	220 +5/-0° C

- Notes:
1. The packages are qualified by Atmel by using IR reflow conditions, not convection or VPR.
 2. By default, the package level 1 is qualified at 220° C (unless 235° C is stipulated).
 3. The body temperature is the most important parameter but other profile parameters such as total exposure time to hot temperature or heating rate may also influence component reliability.

A maximum of three reflow passes is allowed per component.

11. Errata

11.1 Errata for AT91FR40162

This Errata described below refers to:

- The following datasheet:
 - AT91FR40162 Datasheet
- 121-lead BGA devices with the following references in the marking:
AT91FR40162-CI
58A03X

1. Full Chip Erase Command May Not Fully Erase Flash

When using the Full Chip Erase Command to erase the Flash, the Flash may not be fully erased. Some bytes may be different than 0xFF.

Workaround: Erase the Flash sector by sector with the Sector Erase command.

2. Concurrent Read Feature May Lead to Incorrect Flash Accesses

As the Flash is dual-plane, the Concurrent Read feature when programming or erasing is implemented. Using that feature may lead to incorrect Flash accesses.

Workaround: Consider the Flash as single-plane and do not use Concurrent Read feature when programming or erasing.

3. Sector Erase Command May Not Fully Erase the Sector

When using the Sector Erase Command to erase a sector, the Sector Erase operation may not be successful if only few bytes are programmed in the sector.

If there are many programmed bits in the sector, Sector Erase operation is carried out successfully.

Workaround: Before sending a Sector Erase Command, the corresponding sector must be programmed with all bits to 0.

4. Flash Memory Uploader (FMU) Does Not Work at High Speed

Because of lacking wait states, the ROMed FMU does not work at 66 MHz for the following lot IDs: AK1216220, AK2030170, AK3120110, 3R1857, 3.2067, 3R2801, 3R2802, 3R3177, 3R3301, 3S4262, 3S3804 and 3S3805. The maximum frequency for these lots is 40 MHz.

Other lots contain a corrected FMU.

Workaround: None

5. Powering VPP Over VDDIO Might Lead to Partially Erased Sectors.

When using the Sector Erase Command to erase a sector, the Sector Erase operation may not be successful if VPP is higher than VDDIO.

Workaround: VPP must be connected either to ground, VDDIO or left not connected. VPP must not be set to a voltage higher than 3.3V and must be lower or equal to VDDIO.

Note: To be compatible with AT91FR40162S, it is recommended to connect VPP to VDDIO Please refer to the application note: How to Upgrade an AT91FR40162-based system to an AT91FR40162S-based System. [Atmel literature number 6186](#).

Document Details

Title	AT91FR40162 Datasheet
Literature Number	2632
Revision History	
Version A	Publication Date: 28-Feb-02
Version B	Publication Date: 04-Jul-02
<i>Revisions since last issue</i>	
<i>Page: 2</i>	Figure 1 changes: Ball 5H changed to NCSF, ball 5C changed to NBUSY, ball 6D changed to NRSTF.
<i>Page: 18</i>	Table 5, Table 6. Thermal resistance and device and weight data added.
Version C	Publication Date: 24-Mar-04
<i>Revisions since last issue</i>	
<i>Page: 1</i>	Features: 1024K Flash Memory (2M bytes); items removed from list (removed quantified information regarding embedded flash device). Fully Static Operation: changed to 0 Hz to 75 Mhz
<i>Page: 6</i>	Memories: Maximum performance changed to 67 MIPS at 75 MHz.
<i>Page: 12</i>	Flash Memory: Change made to 6-byte command sequence and note added to bullet list (removed quantified information regarding embedded flash device).
<i>Page: 20</i>	Table 7 added, 121-ball BGA Package Characteristics
Version D	
<i>Revisions since last issue</i>	
<i>Global</i>	Section-title numbers introduced in change of template and figure and table numbering properties updated as well.
<i>Page: 4</i>	Table 3-1, "AT91FR40162 Pin Description," on page 3 , Description of VPP to VDDIO detailed in note ⁽¹⁾ to Pin Description with link to Application note.
<i>Page: 20-21</i>	Section 11. "Errata" on page 20 : Errata added to datasheet.



Atmel Corporation

2325 Orchard Parkway
San Jose, CA 95131, USA
Tel: 1(408) 441-0311
Fax: 1(408) 487-2600

Regional Headquarters

Europe

Atmel Sarl
Route des Arsenaux 41
Case Postale 80
CH-1705 Fribourg
Switzerland
Tel: (41) 26-426-5555
Fax: (41) 26-426-5500

Asia

Room 1219
Chinachem Golden Plaza
77 Mody Road Tsimshatsui
East Kowloon
Hong Kong
Tel: (852) 2721-9778
Fax: (852) 2722-1369

Japan

9F, Tonetsu Shinkawa Bldg.
1-24-8 Shinkawa
Chuo-ku, Tokyo 104-0033
Japan
Tel: (81) 3-3523-3551
Fax: (81) 3-3523-7581

Atmel Operations

Memory

2325 Orchard Parkway
San Jose, CA 95131, USA
Tel: 1(408) 441-0311
Fax: 1(408) 436-4314

Microcontrollers

2325 Orchard Parkway
San Jose, CA 95131, USA
Tel: 1(408) 441-0311
Fax: 1(408) 436-4314

La Chantrerie

BP 70602
44306 Nantes Cedex 3, France
Tel: (33) 2-40-18-18-18
Fax: (33) 2-40-18-19-60

ASIC/ASSP/Smart Cards

Zone Industrielle
13106 Rousset Cedex, France
Tel: (33) 4-42-53-60-00
Fax: (33) 4-42-53-60-01

1150 East Cheyenne Mtn. Blvd.
Colorado Springs, CO 80906, USA
Tel: 1(719) 576-3300
Fax: 1(719) 540-1759

Scottish Enterprise Technology Park
Maxwell Building
East Kilbride G75 0QR, Scotland
Tel: (44) 1355-803-000
Fax: (44) 1355-242-743

RF/Automotive

Theresienstrasse 2
Postfach 3535
74025 Heilbronn, Germany
Tel: (49) 71-31-67-0
Fax: (49) 71-31-67-2340

1150 East Cheyenne Mtn. Blvd.
Colorado Springs, CO 80906, USA
Tel: 1(719) 576-3300
Fax: 1(719) 540-1759

Biometrics/Imaging/Hi-Rel MPU/ High Speed Converters/RF Datacom

Avenue de Rochepleine
BP 123
38521 Saint-Egreve Cedex, France
Tel: (33) 4-76-58-30-00
Fax: (33) 4-76-58-34-80

Literature Requests

www.atmel.com/literature

Disclaimer: The information in this document is provided in connection with Atmel products. No license, express or implied, by estoppel or otherwise, to any intellectual property right is granted by this document or in connection with the sale of Atmel products. **EXCEPT AS SET FORTH IN ATMEL'S TERMS AND CONDITIONS OF SALE LOCATED ON ATMEL'S WEB SITE, ATMEL ASSUMES NO LIABILITY WHATSOEVER AND DISCLAIMS ANY EXPRESS, IMPLIED OR STATUTORY WARRANTY RELATING TO ITS PRODUCTS INCLUDING, BUT NOT LIMITED TO, THE IMPLIED WARRANTY OF MERCHANTABILITY, FITNESS FOR A PARTICULAR PURPOSE, OR NON-INFRINGEMENT. IN NO EVENT SHALL ATMEL BE LIABLE FOR ANY DIRECT, INDIRECT, CONSEQUENTIAL, PUNITIVE, SPECIAL OR INCIDENTAL DAMAGES (INCLUDING, WITHOUT LIMITATION, DAMAGES FOR LOSS OF PROFITS, BUSINESS INTERRUPTION, OR LOSS OF INFORMATION) ARISING OUT OF THE USE OR INABILITY TO USE THIS DOCUMENT, EVEN IF ATMEL HAS BEEN ADVISED OF THE POSSIBILITY OF SUCH DAMAGES.** Atmel makes no representations or warranties with respect to the accuracy or completeness of the contents of this document and reserves the right to make changes to specifications and product descriptions at any time without notice. Atmel does not make any commitment to update the information contained herein. Unless specifically provided otherwise, Atmel products are not suitable for, and shall not be used in, automotive applications. Atmel's products are not intended, authorized, or warranted for use as components in applications intended to support or sustain life.



© Atmel Corporation 2005. **All rights reserved.** Atmel®, logo and combinations thereof, Everywhere You Are® and others, are registered trademarks of Atmel Corporation or its subsidiaries. Windows®, and others are the registered trademarks of Microsoft Corporation. ARM®, ARM Powered logo and others are the registered trademarks, or trademarks of ARM, Ltd. Other terms and product names may be the trademarks of others.



Printed on recycled paper.

2632D-ATARM-15-Sep-05

Embedded Secure Document

The file http://atmel.com/dyn/resources/prod_documents/doc6186.pdf is a secure document that has been embedded in this document. Double click the pushpin to view.

