

NCV7430GEVK

Advance Information USB-LIN Interface V3 Evaluation Board User's Manual



ON Semiconductor®

<http://onsemi.com>

EVAL BOARD USER'S MANUAL

Introduction

USB-LIN Interface provides a simple USB interface that connects PC and LIN based slave device. The USB part is self-powered and optically isolated from the LIN transceiver that can be supplied either via dedicated DC input connector or directly via LIN connector. This device is compatible e.g. with NCV7430 Evaluation software which incorporates all the necessary drivers.

The design incorporates the lowest bill of materials, minimized board size and allows easy interconnection in case of multiple nodes network.

Features

- LIN Compliant to 2.0 and 2.1 and J2602 Specification
- USB Driven LIN Master Node
- Bus-powered USB
- Optically Isolated LIN Bus
- Precise LIN Frames Timing
- Wide Supply Voltage Range
- ESD Protected

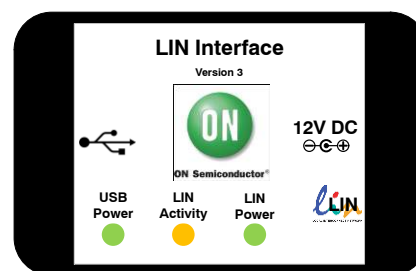

Figure 1. Hardware

Table 1. ABSOLUTE MAXIMUM RATINGS

(ON Semiconductor LIN Interface works in combination with the custom NCV7430 Evaluation GUI interface. No additional power supply is needed other than the supplied 12 V AC/DC adapter which powers the LIN Interface through DC Power Input connector.)

Symbol	Parameter	Min	Max	Units
V_{BUS}	USB Supply Voltage	-0.3	5.5	V
V_{BAT}	External Supply Voltage	-0.3	42	V
I_{BAT}	Maximum supply current	-	2	A
V_{LIN}	Maximum voltage at LIN bus pin	-45	45	V
T_A	Ambient temperature	-40	85	°C

Stresses exceeding Maximum Ratings may damage the device. Maximum Ratings are stress ratings only. Functional operation above the Recommended Operating Conditions is not implied. Extended exposure to stresses above the Recommended Operating Conditions may affect device reliability.

Table 2. RECOMMENDED OPERATING RATINGS

Symbol	Parameter	Min	Max	Units
V_{BUS}	USB Supply Voltage	4.75	5.25	V
V_{BAT}	External Supply Voltage	5.5	18	V
V_{LIN}	Maximum voltage at LIN bus pin	5.5	18	V
T_A	Ambient temperature	-40	85	°C

This document contains information on a new product. Specifications and information herein are subject to change without notice.

NCV7430GEVK

Table 3. PIN FUNCTION DESCRIPTION

Connector	Pin	Pin Name	Description
LIN INTERFACE			
Power			V _{BAT} External Power Supply Input (LIN Bus side)
LIN (RJ11)	1	V _{BAT}	V _{BAT} Supply Voltage Output / Input (LIN Interface can be supplied through this pin)
	2	LIN	LIN Bus Line
	3	GND	Ground Connection
	4	NC	Not Connected
USB			USB Connector

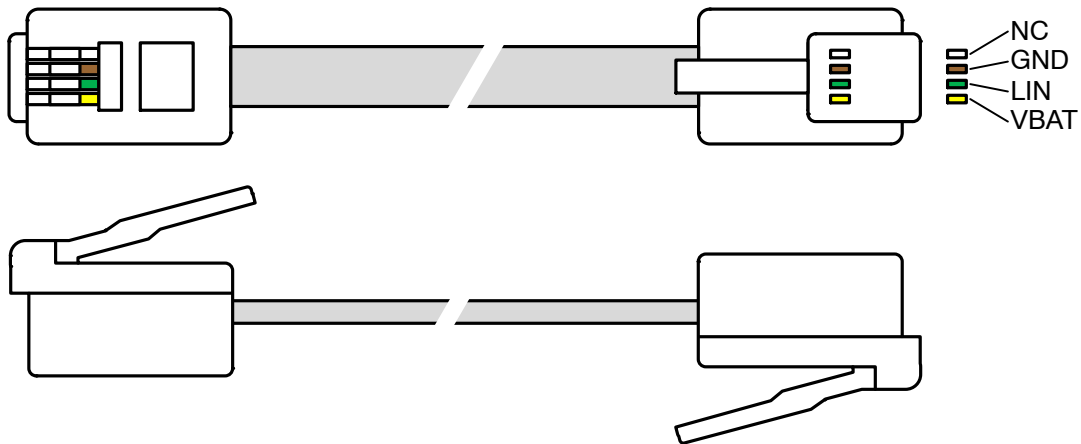

Figure 2. LIN Cable with RJ11 4P4C Connectors (Top View and Side View)

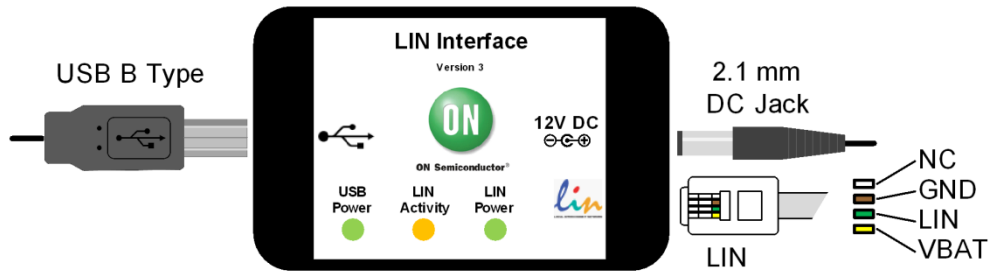

Figure 3. USB-LIN Interface Connectors

NCV7430GEVK

GETTING STARTED

This section contains instructions for the NCV7430 setup configuration and first connection. Only a few steps need be proceeded to get fully working simple LIN RGB LED network.

Please take the following steps to get a functional setup:

1. Install the NCV7430 Evaluation Software (see the NCV7430 Evaluation Software section for details). The USB drivers are included in the installation package. This installation requires administrator rights.

2. Connect LIN Interface to USB and wait until the device is installed. This step requires administrator rights.
3. Connect the boards according to figure below. Initially all the nodes have address set to default value 0. In case the node addresses haven't been set previously, connect only one node to USB-LIN interface to avoid having two nodes with same address connected to the network.

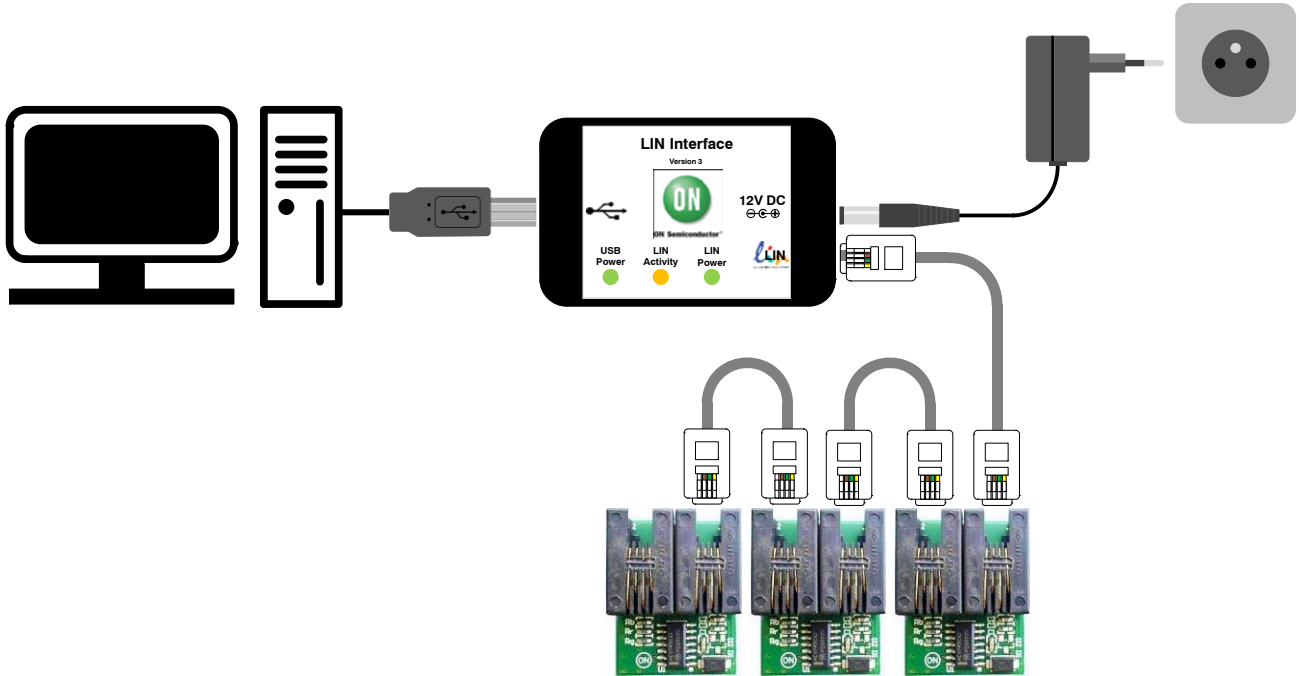

Figure 4. Example of LIN Interface Connection – NCV7430 Evaluation Setup

4. Run the NCV7430 Evaluation Software.

5. Select one of the nodes from “Nodes” table (detected nodes are highlighted in yellow),

NCV7430GEVK

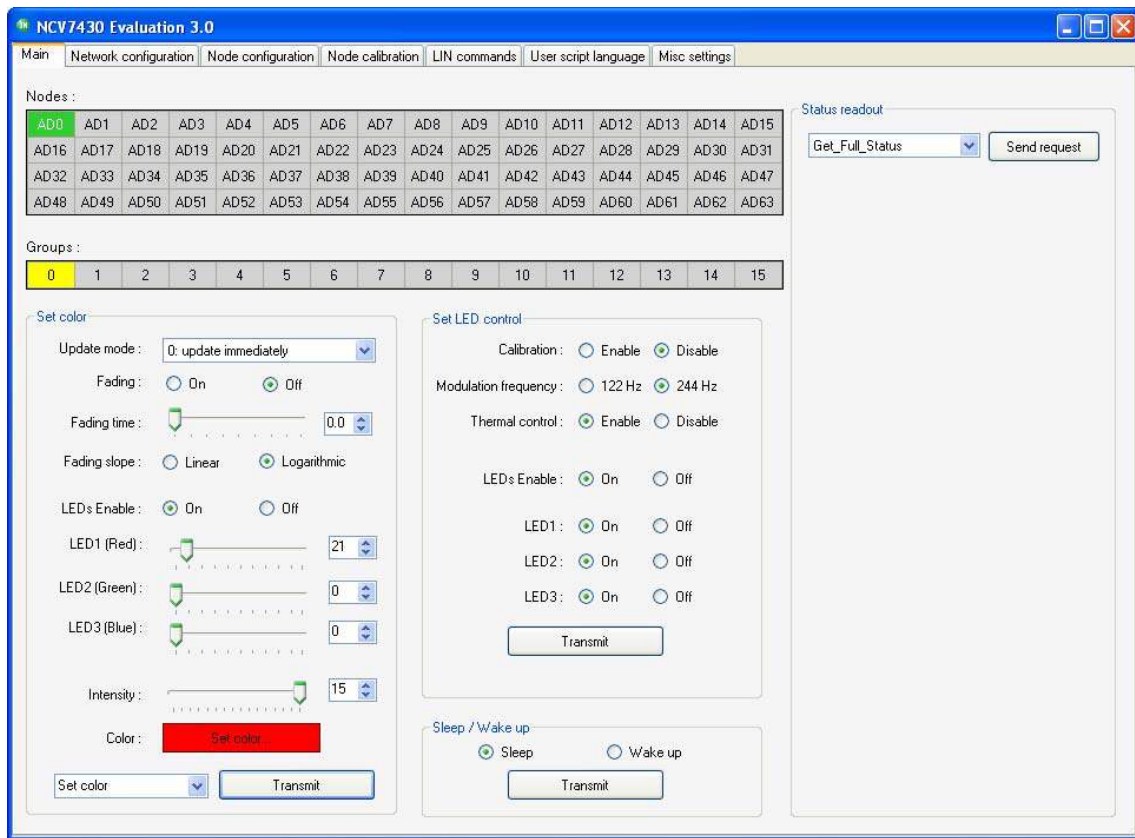

Figure 5. NCV7430 Evaluation Software Preview

6. To switch the LED to On state set the parameters in Set Color group box according to picture below and select Transmit. The color setting can be freely modified. Then set the parameters in

Set LED Control group box and select Transmit. These two commands can be sent in any order.

7. LED should be turned on with preset color.

NCV7430 EVALUATION SOFTWARE

ON Semiconductor LIN Interface works in combination with the custom NCV7430 Evaluation Software.

Minimum Requirements

Operating System

- Windows XP, SP3 (32/64-bit)
- Windows Vista, SP1 (32/64-bit)
- Windows 7 (32/64-bit)
- Microsoft .NET Framework 4.0

Hardware requirements

- Processor 1 GHz
- RAM 512 MB
- Disk Space 850 MB (32-bit system)
2 GB (64-bit system)
- Monitor resolution – minimum 800 x 600 pixels
- USB port

(The minimum disk space requirement is based on Microsoft .NET Framework 4.0 system requirements)

Installation Procedure

1. Please check if Microsoft .NET Framework 4.0 is installed on your computer. If not, run **dotNetFx40_Full_setup.exe** prior to the NCV7430 Evaluation software installation.
2. Run **NCV7430 Evaluation Setup.exe** and follow the installation wizard instructions.

Driver Setup

USB drivers should be installed automatically with the software. Once installed, you can plug the LIN Interface into the USB port. The hardware should be installed automatically and following message should be displayed:

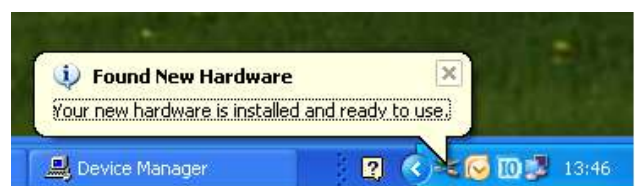

Figure 6. Found New Hardware Message

NCV7430GEVK

The installation can be checked in Device Manager. When the hardware is connected, you should be able to find *USB Serial Converter A* and *B* in *Universal Serial Bus controllers* group.

In case you encounter any problem with the drivers, try installing the drivers manually. The drivers can be found on <http://www.ftdichip.com/Drivers/D2XX.htm> – D2XX drivers – also available as executable file.

LIN Commands Tab

The LIN commands tab has two functions. It monitors all the LIN bus traffic and allows sending a custom frame. Transmitted or received commands are listed in a table together with a time stamp and description of the frame.

In the Frame Creator group box, fill all the necessary fields and click the Data transfer button to send the custom frame.

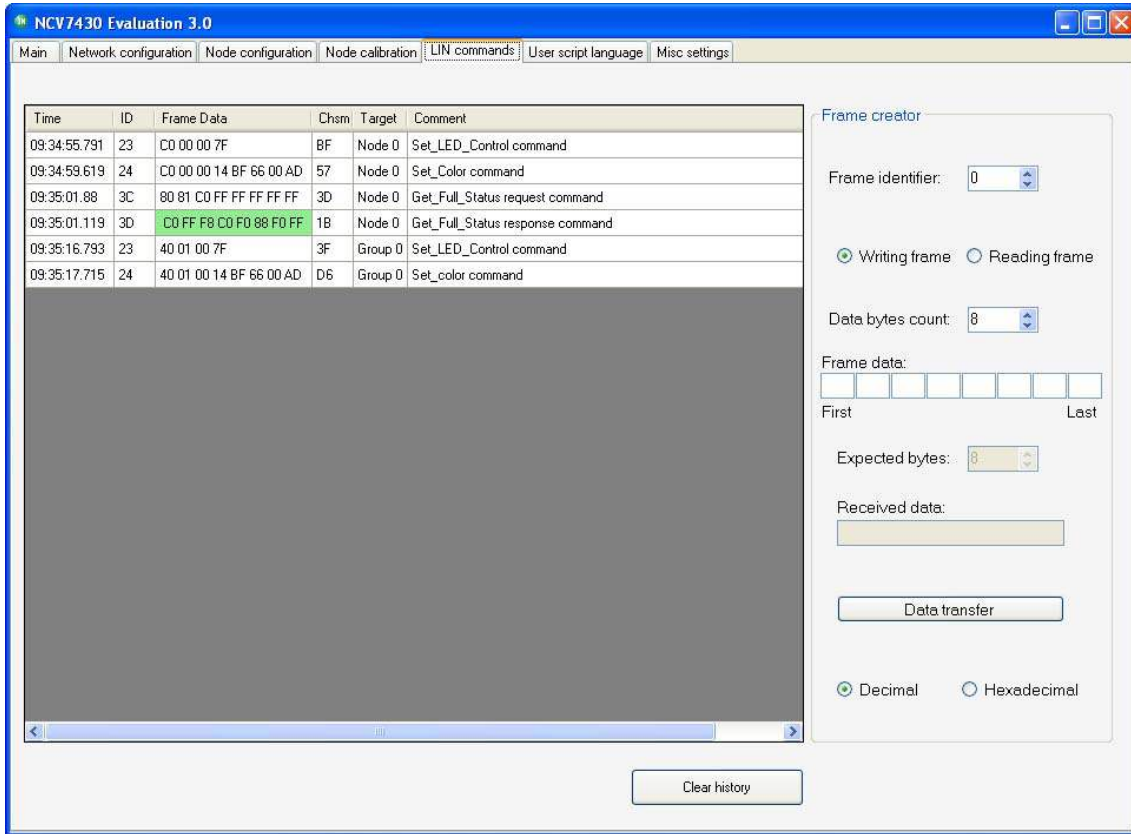

Figure 7. LIN Commands Tab

MISC Settings Tab

The last Misc settings tab is used to set LIN baud-rate and additional OTP programming actions:

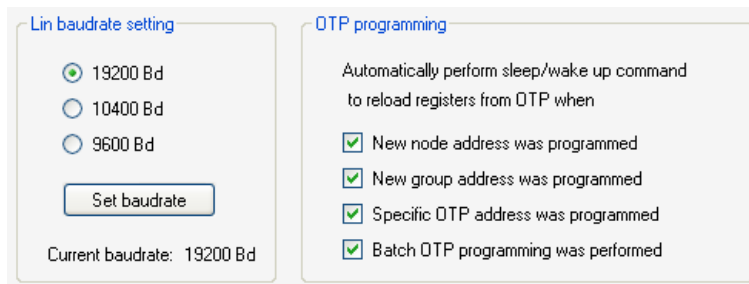
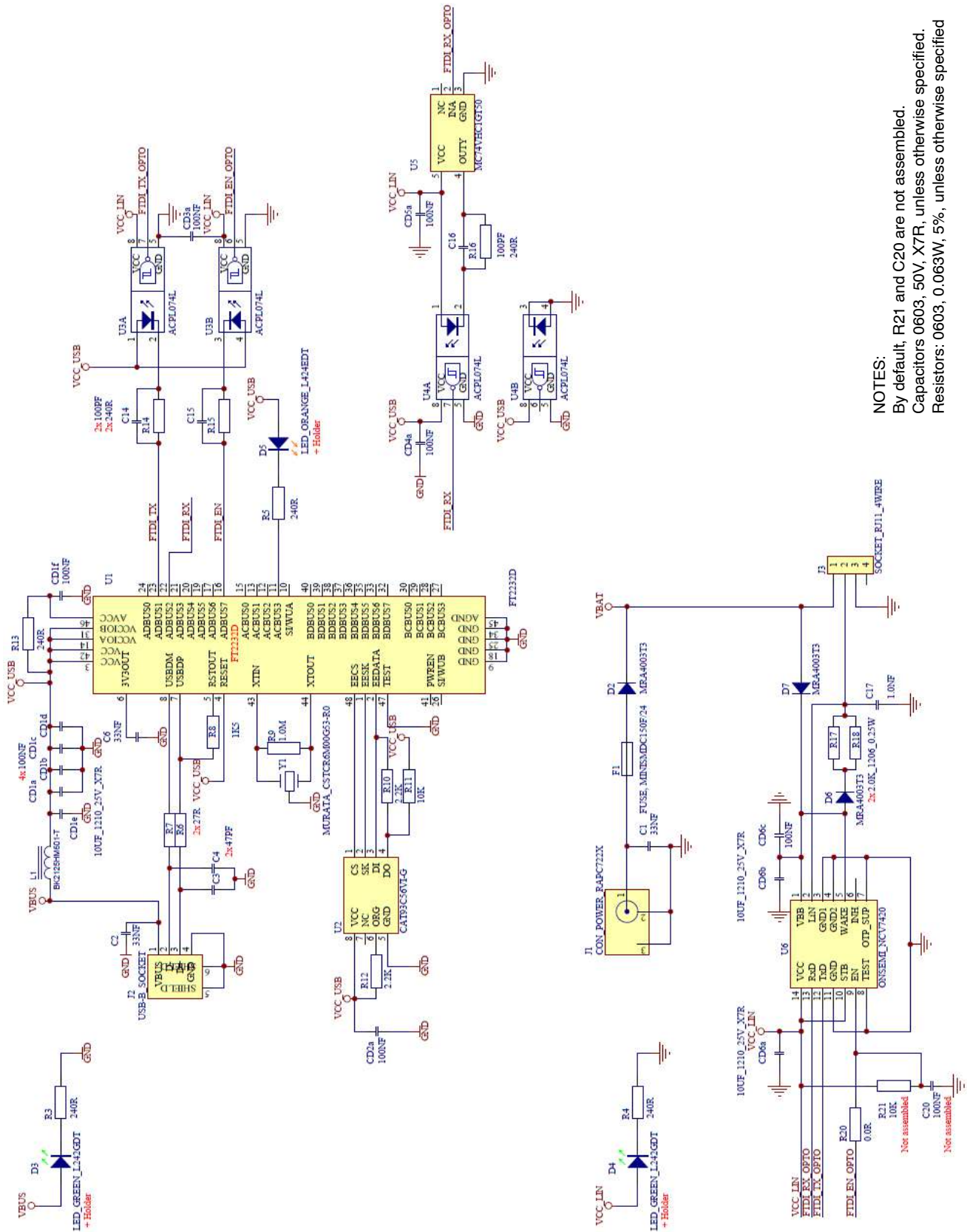

Figure 8. LIN Baud-rate Settings

For more details about the NCV7430 Evaluation software functions and possibilities, please see the NCV74300V1GEVB Evaluation Board User's Manual.

NCV7430GEVK

SCHEMATIC



NOTES:
 By default, R21 and C20 are not assembled.
 Capacitors 0603, 50V, X7R, unless otherwise specified.
 Resistors: 0603, 0.063W, 5%, unless otherwise specified

NCV7430GEVK

BILL OF MATERIALS

Table 4. LIN INTERFACE V3 BILL OF MATERIALS

Designator	Qty	Description	Value	Tol	Footprint	Manufacturer	Manufacturer Part Number	Subst. Allowed
R3, R4, R5, R13, R14, R15, R16	7	Resistor	240 Ω	±5%	0603	MULTICOMP	MC0063W06031240R	Yes
R6, R7	2	Resistor	27 Ω	±5%	0603	MULTICOMP	MC 0.063W 0603 5% 27R	Yes
R8	1	Resistor	1,5 kΩ	±5%	0603	MULTICOMP	MC 0.063W 0603 5% 1K5	Yes
R9	1	Resistor	1.0 MΩ	±5%	0805	MULTICOMP	MC01W080511M	Yes
R10, R12	2	Resistor	2.2 kΩ	±5%	0603	MULTICOMP	MC 0.063W 0603 5% 2K2	Yes
R11, R21	2	Resistor	10 kΩ	±5%	0603	YAGEO (PHYCOMP)	RC0603JR-0710KL	Yes
R17, R18	2	LIN Bus Master Pull-up	2.0 kΩ, 0.25 W	±1%	1206	WELWYN	WCR1206-2KFI	Yes
R20	1	Resistor	0.0 Ω		0603	YAGEO (PHYCOMP)	RC0603JR-070RL	Yes
C1, C2, C6	3	Filter Capacitor	33 nF	±10%	0603	EPCOS	GRM188R71H333KA61D	Yes
C3, C4	2	USB Bus Filter Capacitor	47 pF	±10%	0603	KEMET	C0603C470J5GACTU	Yes
CD1e, CD6a, CD6b	3	Supply Filter Capacitor	10 μF, 25 V	±10%	1210	KEMET	C1210X106K3RACTU	Yes
C20, CD1a, CD1b, CD1c, CD1d, CD1f, CD2a, CD3a, CD4a, CD5a, CD6c	11	Supply Filter Capacitor	100 nF	±10%	0603	KEMET	C0603C104K5RACTU	Yes
C14, C15, C16	3	Capacitor	100 pF	±10%	0603	YAGEO (PHYCOMP)	CC0603KRX7R9BB101	Yes
C17	1	LIN Filter Capacitor	1.0 nF	±10%	0603	MULTICOMP	U0603R102KCT	Yes
D2, D6, D7	3	Reverse Battery Diode	MRA4003T3		SMA	ON SEMICONDUCTOR	MRA4003T3G	No
D3, D4	2	Indication LED	GREEN L242GDT		LED 3MM TH	KINGBRIGHT	L-424GDT	Yes
D5	1	Indication LED	ORANGE L424EDT		LED 3MM TH	KINGBRIGHT	L-424EDT	Yes
H1, H2, H3	3	LED Holder	6.5 mm		Round, 5mm, 2 pin	MULTICOMP	LED-6.5A	Yes
L1	1	Ferrite Chip Bead	600 Ω @100 MHz		0805	TAIYO YUDEN	BK2125HM601-T	Yes
F1	1	PTC Resettable Fuse	MINISMDC150F /24		FUSE_MINISMDC	RAYCHEM	MINISMDC150F/24	Yes
Y1	1	Ceramic Resonator	6.0 MHz		CSTCR6M00G53	MURATA	CSTCR6M00G53-R0	Yes
U1	1	USB-UART Convertor	FT2232D		LQFP48 7X7	FTDI	FT2232D/TR	Yes
U2	1	Serial EEPROM	CAT93C56VI-G		SOIC-8	ON SEMICONDUCTOR	CAT93C56VI-GT3	No
U3, U4	2	Optocoupler	ACPL074L		SOIC-8	AVAGO TECHNOLOGIES	ACPL-074L-000E	Yes
U5	1	CMOS Logic Level Shifter	MC74VHC1GT50		SOT-23-5	ON SEMICONDUCTOR	M74VHC1GT50DTT1G	No
U6	1	LIN Transceiver + 5 V LDO	NCV7420D26G		SOIC-14	ON SEMICONDUCTOR	NCV7420D26G	No
J1	1	DC Supply Socket	RAPC722X		RAPC722X TH	SWITCHCRAFT	RAPC722X	Yes

NCV7430GEVK

Table 4. LIN INTERFACE V3 BILL OF MATERIALS

Designator	Qty	Description	Value	Tol	Footprint	Manufacturer	Manufacturer Part Number	Subst. Allowed
J2	1	USB B-Type Socket	USB_B_SOCKET		USB-B TH	LUMBERG	2411 02	Yes
J3	1	LIN Bus Socket	RJ11_4P4C		87180-044LF TH	FCI	87180-044LF	Yes
CASE1	1	Plastic Enclosure	CASE_HH3466			BUD INDUSTRIES	HH-3466	Yes

PCB DRAWINGS

Assembly Drawings

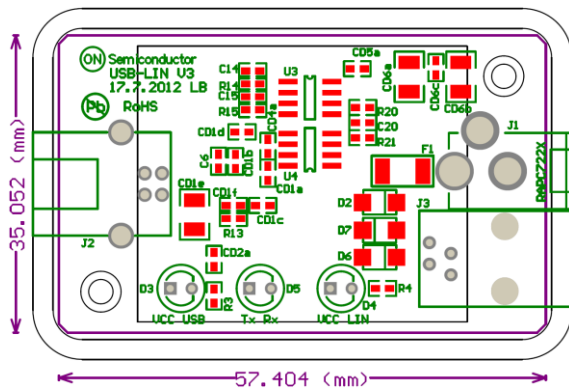

Figure 9. LIN Interface V3 Top Assembly Drawing

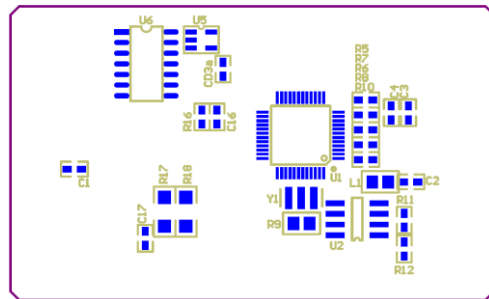

Figure 10. LIN Interface V3 Bottom Assembly Drawing

Composite Drawings

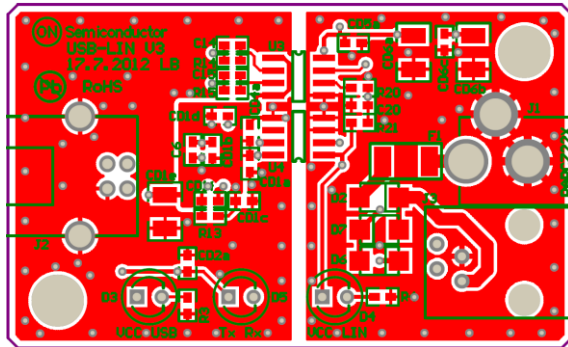

Figure 11. LIN Interface V3 PCB Top Composite Drawing

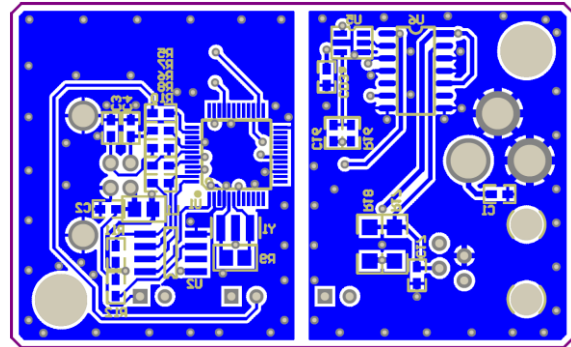



Figure 12. LIN Interface V3 PCB Bottom Composite Drawing

ON Semiconductor and  are registered trademarks of Semiconductor Components Industries, LLC (SCILLC). SCILLC owns the rights to a number of patents, trademarks, copyrights, trade secrets, and other intellectual property. A listing of SCILLC's product/patent coverage may be accessed at www.onsemi.com/site/pdf/Patent-Marking.pdf. SCILLC reserves the right to make changes without further notice to any products herein. SCILLC makes no warranty, representation or guarantee regarding the suitability of its products for any particular purpose, nor does SCILLC assume any liability arising out of the application or use of any product or circuit, and specifically disclaims any and all liability, including without limitation special, consequential or incidental damages. "Typical" parameters which may be provided in SCILLC data sheets and/or specifications can and do vary in different applications and actual performance may vary over time. All operating parameters, including "Typicals" must be validated for each customer application by customer's technical experts. SCILLC does not convey any license under its patent rights nor the rights of others. SCILLC products are not designed, intended, or authorized for use as components in systems intended for surgical implant into the body, or other applications intended to support or sustain life, or for any other application in which the failure of the SCILLC product could create a situation where personal injury or death may occur. Should Buyer purchase or use SCILLC products for any such unintended or unauthorized application, Buyer shall indemnify and hold SCILLC and its officers, employees, subsidiaries, affiliates, and distributors harmless against all claims, costs, damages, and expenses, and reasonable attorney fees arising out of, directly or indirectly, any claim of personal injury or death associated with such unintended or unauthorized use, even if such claim alleges that SCILLC was negligent regarding the design or manufacture of the part. SCILLC is an Equal Opportunity/Affirmative Action Employer. This literature is subject to all applicable copyright laws and is not for resale in any manner.

PUBLICATION ORDERING INFORMATION

LITERATURE FULFILLMENT:

Literature Distribution Center for ON Semiconductor
P.O. Box 5163, Denver, Colorado 80217 USA
Phone: 303-675-2175 or 800-344-3860 Toll Free USA/Canada
Fax: 303-675-2176 or 800-344-3867 Toll Free USA/Canada
Email: orderlit@onsemi.com

N. American Technical Support: 800-282-9855 Toll Free
USA/Canada
Europe, Middle East and Africa Technical Support:
Phone: 421 33 790 2910
Japan Customer Focus Center
Phone: 81-3-5817-1050

ON Semiconductor Website: www.onsemi.com

Order Literature: <http://www.onsemi.com/orderlit>

For additional information, please contact your local
Sales Representative