

注記 NOTES

1. 使用材料 MATERIAL

ハウジング: 液晶ポリマー (LCP) ガラス充填 UL94V-0 (黒)
 HOUSING: LIQUID CRYSTAL POLYMER (GLASS FILLED) UL94V-0 (COLOR: BLACK)
 ターミナル: りん青銅 (t=0.1)
 TERMINAL: PHOSPHOR BRONZE (t=0.1)

2. メッキ仕様 PLATING

ターミナル TERMINAL

金メッキ 0.1 マイクロメートル以上 (コンタクト部)
 GOLD 0.1 MICROMETER MINIMUM (CONTACT AREA)
 金メッキ 0.05 マイクロメートル以上 (テール部)
 GOLD 0.05 MICROMETER MINIMUM (TAIL AREA)
 下地メッキ: ニッケルメッキ 1.0 マイクロメートル以上
 UNDER PLATING: NICKEL 1.0 MICROMETER MINIMUM

※コンタクト部とテール部はニッケルメッキによって分断されている金メッキです。
 DIVIDE INTO PARTS THE GOLD PLATING OF THE CONTACT AND THE TAIL PART BY THE NICKEL PLATING.

※封孔処理品
 SEALING TREATMENT

- △ (全極数/2)=偶数の場合に適用.
 APPLY FOR (CIRCUIT/2)=EVEN.
4. 嵌合相手: 503108 シリーズ
 MATE WITH: 503108 SERIES.
5. テール平坦度は、0.1 以下
 TAIL COPLANARITY TO BE 0.1 MAXIMUM.
6. ELV 及び RoHS 適合品
 ELV AND ROHS COMPLIANT.

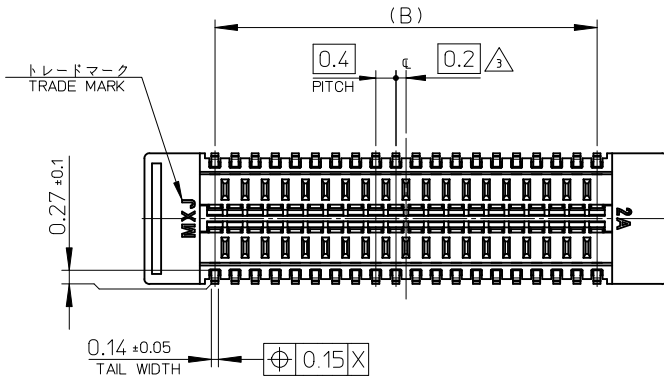
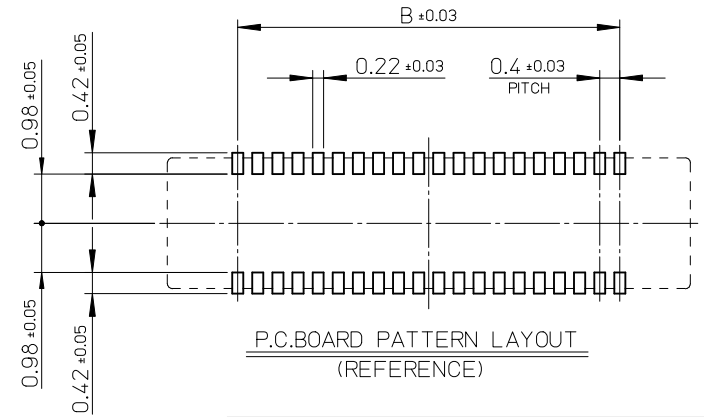
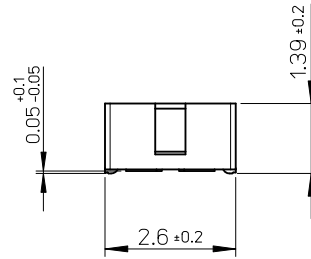
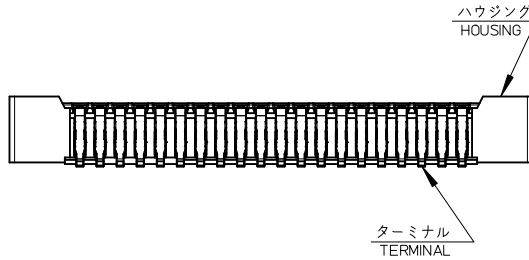
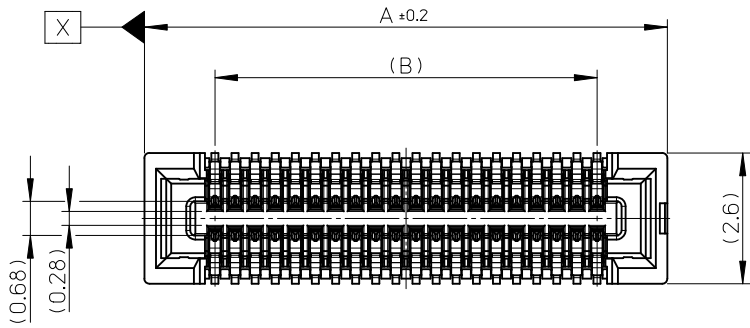

9.6	12.4	503105-5010	50
8.4	11.2	503105-4410	44
7.6	10.4	503105-4010	40
5.6	8.4	503105-3010	30
B	A	EMBOSSED TAPE	CKT.
		ORDER No. オーダー番号	
		CONNECTOR SERIES No.: 503105-***19	

REVISED EC NO.: J2011-0740 DRWNK: TOYODA 2010/11/29 CHKD: MSASAO 2010/11/29 APPR: MSASAO 2011/02/21	GENERAL TOLERANCES (UNLESS SPECIFIED)		DIMENSION STYLE MM ONLY		SCALE 10:1	DESIGN UNITS METRIC	THIRD ANGLE PROJECTION
	10 UNDER	± ---	DRAWN BY RTAKEUCHI	DATE 2008/07/02	TITLE 0.4 B-TO-B CONN. HGT=1.5 W=2.6 W/O NAIL REC ASSY		
	10 OVER 30 UNDER	± ---	CHECKED BY MSASAO	DATE 2008/07/02	MOLEX INCORPORATED		
	30 OVER	± ---	APPROVED BY MSASAO	DATE 2008/07/02	DOCUMENT NO. SD-503105-001	SHEET NO. 1 OF 1	
REV	DESCRIPTION	ANGULAR ± --- °	MATERIAL NO. SEE CHART		THIS DRAWING CONTAINS INFORMATION THAT IS PROPRIETARY TO MOLEX INCORPORATED AND SHOULD NOT BE USED WITHOUT WRITTEN PERMISSION		
		DRAFT WHERE APPLICABLE MUST REMAIN WITHIN DIMENSIONS					

注記 NOTES

- 製品詳細寸法については製品単体図面を参照下さい。
RE DETAILED DIMENSION, SEE PRODUCT DRAWING.
- 梱包数量：3000 個/リール
NUMBER OF CONNECTORS : 3000PCS/REEL
- リードテープ長さ LEAD TAPE LENGTH

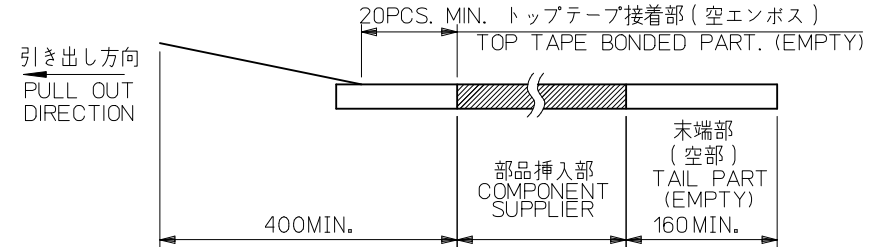

- トップテープの剥離強度：0.1N~1.3N(10gf~130gf)
(剥離方向は下図参照)
尚、本規格値は出荷時に適用。(但し、輸送時に剥離が発生しないこと。)
PEELING OFF FORCE OF TOP TAPE : 0.1N~1.3N(10gf~130gf)
(PEELING DIRECTION AS SHOWN IN FOLLOWING FIG.)
THIS REQUIREMENT SHOULD BE APPLIED AT SHIPMENT.
PEEL OFF SHOULD NOT BE ALLOWED , DURING TRANSPORTION.

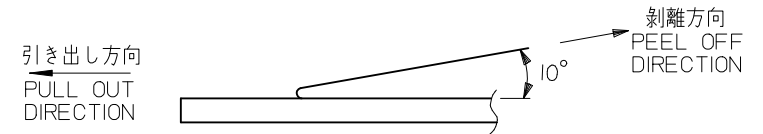

- 材料 MATERIAL
キャリアテープ (CARRIER TAPE) : ポリスチレン (POLYSTYRENE)
トップテープ (TOP TAPE) : PET , PE , PEF
リール (REEL) : ポリスチレン (PS) <リサイクル材を含む>
POLYSTYRENE (PS) <RECYCLE MATERIAL CONTAINED>
- ELV 及び RoHS適合品
ELV AND RoHS COMPLIANT

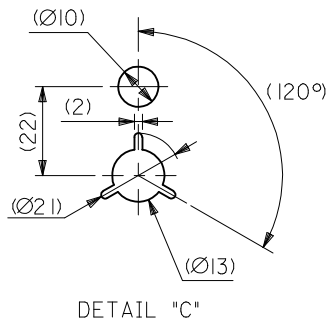
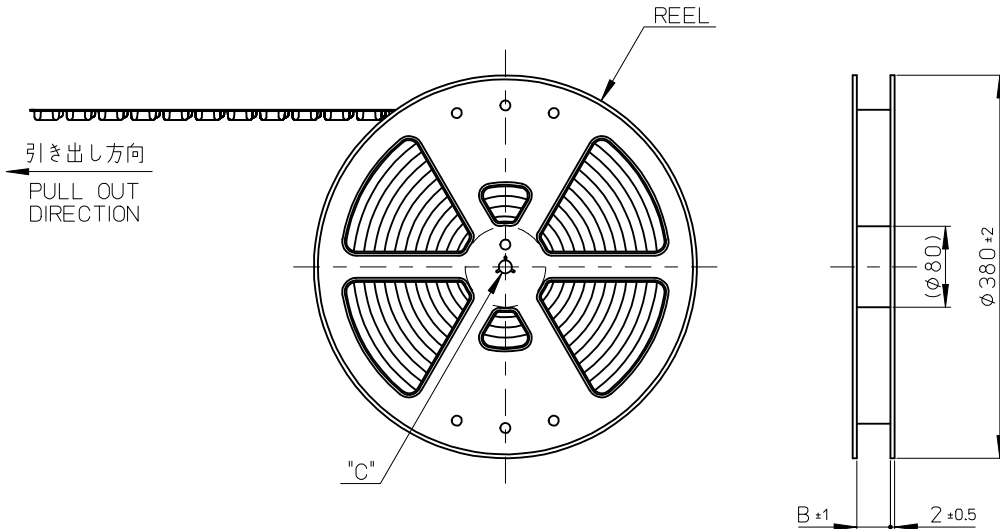

REVISED EC NO: J2013-1009 DRWN:KTOYODA 2013/03/13 CHKD:TASAKAWA 2013/03/13 APPR:MSASAO 2013/03/13	DESCRIPTION REV	GENERAL TOLERANCES (UNLESS SPECIFIED)		DIMENSION STYLE MM ONLY	SCALE ---	DESIGN UNITS METRIC	MODEL NO. 503105-**10	
		10 UNDER	±---	DRAWN BY RTAKEUCHI	DATE 2008/08/20	TITLE 0.4 B-TO-B CONN. HGT=1.5 REC ASSY EMBSTP PKG		
		10 OVER 30 UNDER	±---	CHECKED BY THIRATA	DATE 2008/08/20			
		30 OVER	±---	APPROVED BY MSASAO	DATE 2008/08/20			
ANGULAR ±---°		DRAFT WHERE APPLICABLE MUST REMAIN WITHIN DIMENSIONS		MATERIAL NO. SEE CHART	DOCUMENT NO. SD-503105-002	SHEET NO. 1 OF 3		
THIS DRAWING CONTAINS INFORMATION THAT IS PROPRIETARY TO MOLEX INCORPORATED AND SHOULD NOT BE USED WITHOUT WRITTEN PERMISSION								

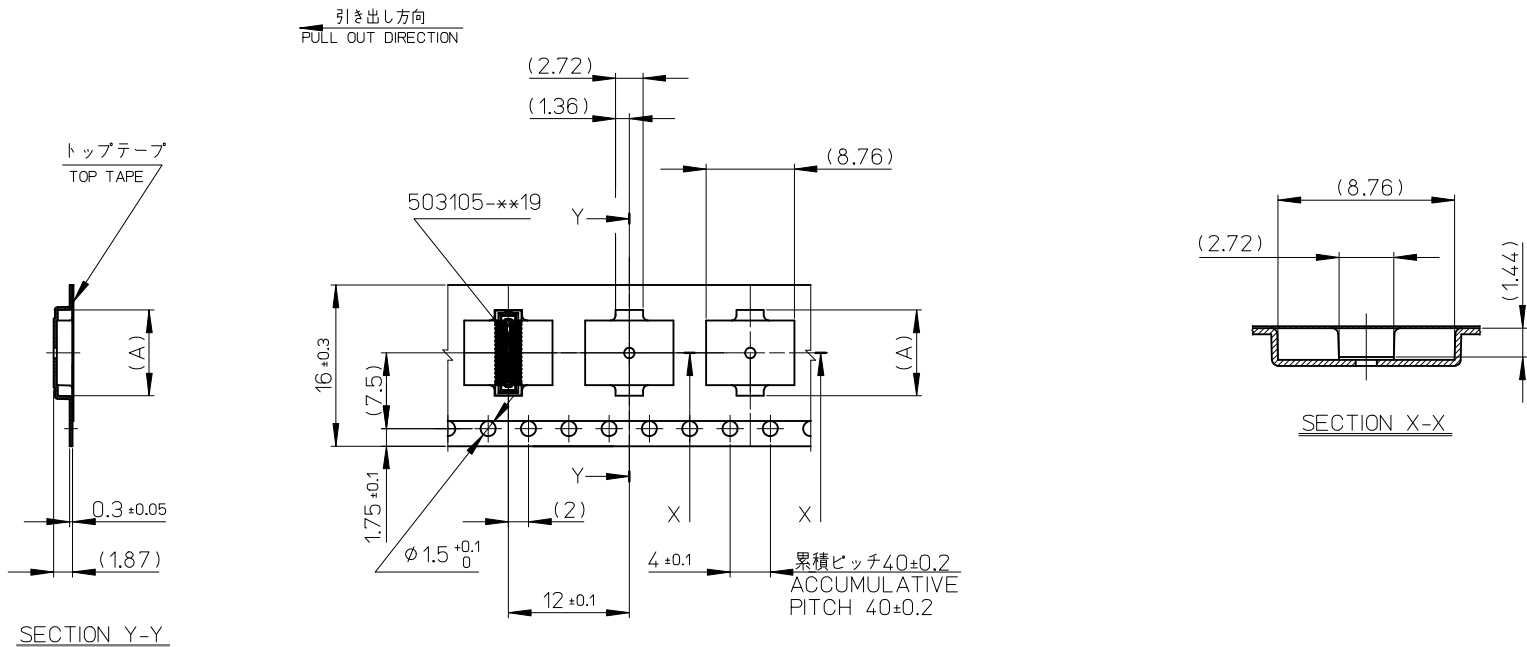

16mm 幅キャリアテープ
16mm WIDTH CARRIER TAPE

16	17.4	8.52	503105-3010	30
キャリアテープ幅 CARRIER TAPE WIDTH	B	(A)	MATERIAL No.	CKT.
			MODEL No.	503105-**10

SEE SHEET 1 OF 3 EC NO.: J2013-1009 DRWNG: TOYODA 2013/03/13 CHK'D: TASAKAWA 2013/03/13 APPR: MSASAO 2013/03/13	GENERAL TOLERANCES (UNLESS SPECIFIED)	DIMENSION STYLE MM ONLY	SCALE ---	DESIGN UNITS METRIC	THIRD ANGLE PROJECTION
	10 UNDER ± --- 10 OVER 30 UNDER ± --- 30 OVER ± --- ANGULAR ± --- ° DRAFT WHERE APPLICABLE MUST REMAIN WITHIN DIMENSIONS	DRAWN BY: RTAKEUCHI DATE: 2008/08/20 CHECKED BY: THIRATA DATE: 2008/08/20 APPROVED BY: MSASAO DATE: 2008/08/20	TITLE 0.4 B-TO-B CONN. HGT=1.5 REC ASSY EMBSTP PKG		molex DOCUMENT NO. SD-503105-002 SHEET NO. 2 OF 3
		MATERIAL NO.	SEE CHART		
			SIZE A3	THIS DRAWING CONTAINS INFORMATION THAT IS PROPRIETARY TO MOLEX INCORPORATED AND SHOULD NOT BE USED WITHOUT WRITTEN PERMISSION	

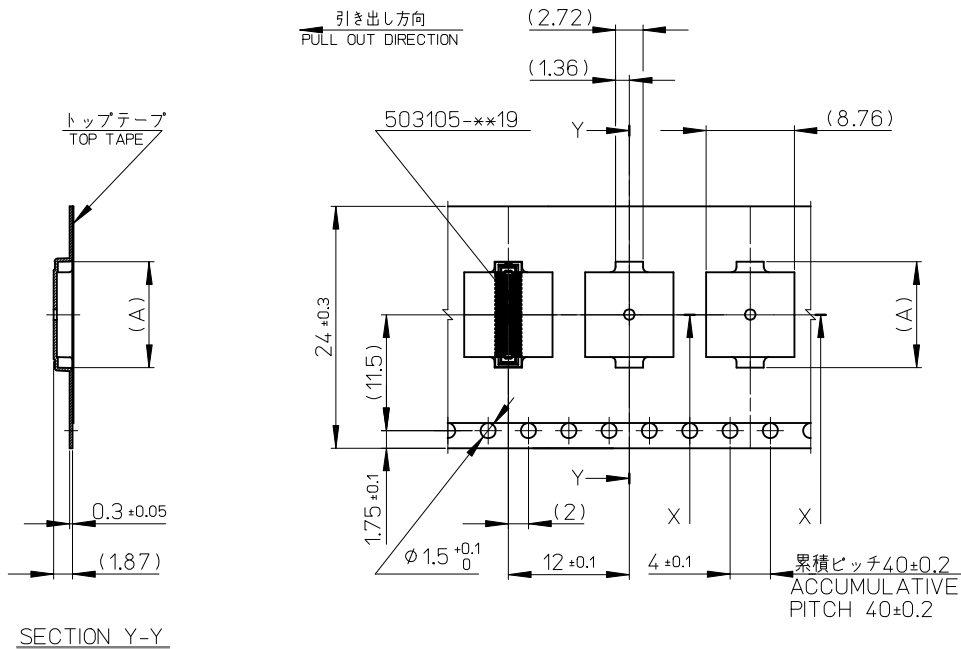

24mm 幅キャリアテープ
24mm WIDTH CARRIER TAPE

24	25.5	12.52	503105-5010	50
		11.32	503105-4410	44
		10.52	503105-4010	40
キャリアテープ幅 CARRIER TAPE WIDTH	B	(A)	MATERIAL No.	CKT.
			MODEL No.	503105-**-**10

SEE SHEET 1 OF 3 EC NO.: J2013-1009 DRW:KTOYODA 2013/03/13 CHKD:TASAKAWA 2013/03/13 APPR:MSASAO 2013/03/13	GENERAL TOLERANCES (UNLESS SPECIFIED)	DIMENSION STYLE MM ONLY	SCALE ---	DESIGN UNITS METRIC	THIRD ANGLE PROJECTION
	10 UNDER ±---	DRAWN BY RTAKEUCHI	DATE 2008/08/20	TITLE 0.4 B-TO-B CONN. HGT=1.5 REC ASSY EMBSTP PKG	
	10 OVER 30 UNDER ±---	CHECKED BY THIRATA	DATE 2008/08/20	molex	
	30 OVER ±---	APPROVED BY MSASAO	DATE 2013/03/13		
	ANGULAR ±---°	MATERIAL NO.	SEE CHART	DOCUMENT NO. SD-503105-002	SHEET NO. 3 OF 3
DRAFT WHERE APPLICABLE MUST REMAIN WITHIN DIMENSIONS	SIZE A3	THIS DRAWING CONTAINS INFORMATION THAT IS PROPRIETARY TO MOLEX INCORPORATED AND SHOULD NOT BE USED WITHOUT WRITTEN PERMISSION			