



Embedded Storage

FerriSSD[®] SATA Gen 3 DRAM BGA SSD

Dx Series

Datasheet

(Simplified Edition)

Document Confidentiality Statement

The information contained in these documents is confidential, privileged and only for the information of the intended recipient and should not be disclosed to any other person. It may not be used, published or redistributed in whole, or in part, nor may any of the information contained therein be disclosed without the prior written consent of Silicon Motion, Inc. and its affiliates (collectively "SMI").

The recipient hereby agrees that reading of this datasheet is strictly limited to her/him as authorized by SMI. If any statement, notice, requirement and/or disclaimer set forth hereunder is unacceptable, the recipient shall return this document to SMI's contact window without any delay or it is deemed to be agreed and accepted by the recipient and her/his representing companies, incorporations, or any legal entity of these statements, notices, requirements and/or disclaimers.

IMPORTANT NOTICE

INFORMATION IN THIS DOCUMENT IS PROVIDED IN CONNECTION WITH PRODUCTS OF SILICON MOTION, INC. AND ITS AFFILIATES (COLLECTIVELY "SMI"). ALL PRODUCT, PRODUCT SPECIFICATIONS AND DATA ARE SUBJECT TO CHANGE WITHOUT NOTICE TO IMPROVE RELIABILITY, FUNCTION OR DESIGN OR OTHERWISE. NO LICENSE, EXPRESS OR IMPLIED, BY ESTOPPEL OR OTHERWISE, TO ANY INTELLECTUAL PROPERTY RIGHTS IS GRANTED BY THIS DOCUMENT. EXCEPT AS PROVIDED IN SMI'S TERMS AND CONDITIONS OF SALE FOR SUCH PRODUCTS, SMI ASSUMES NO LIABILITY WHATSOEVER, AND SMI DISCLAIMS ANY EXPRESS OR IMPLIED WARRANTY, RELATING TO SALE AND/OR USE OF SMI PRODUCTS INCLUDING LIABILITY OR WARRANTIES FOR FITNESS FOR A PARTICULAR PURPOSE, MERCHANTABILITY, OR INFRINGEMENT OF ANY PATENT, COPYRIGHT OR OTHER INTELLECTUAL PROPERTY RIGHT.

SMI, its agents, and employees, and all persons acting on its or their behalf, disclaim any and all liability for any errors, inaccuracies or incompleteness contained in any datasheet or in any other disclosure relating to any product.

Statements regarding the suitability of products for certain types of applications are based on SMI's knowledge of typical requirements that are often placed on SMI's products in generic applications. Such statements are not binding statements about the suitability of products for a particular application. It is customer's responsibility to validate that a particular product with the properties described in the product specification and/or datasheet is suitable for use in a particular application.

SMI products are not intended for use in medical, life saving, life sustaining, critical control or safety systems, or in nuclear facility applications. SMI may make changes to specifications and product descriptions at any time, without notice. SMI may have patents or pending patent applications, trademarks, copyrights, or other intellectual property rights that relate to the presented subject matter. The furnishing of documents and other materials and information does not constitute any license, express or implied, by estoppel or otherwise, to any such patents, trademarks, copyrights, or other intellectual property rights. The information in this document is furnished for informational use only, is subject to change without notice, and should not be construed as a commitment by SMI. SMI assumes no responsibility or liability for any errors or inaccuracies that may appear in this document or any software that may be provided in association with this document. Except as permitted by the permitted use abovementioned, no part of this document may be reproduced, stored in a retrieval system, or transmitted in any form or by any means without the express written consent of SMI. Contact your local SMI sales office or your distributor to obtain the latest specifications and before placing your product order.

Silicon Motion and Silicon Motion logo are registered trademarks of SMI and/or its affiliates. Other brand names mentioned herein are for identification purposes only and may be trademarks and/or registered trademarks of their respective owners.

Revision History

Revision	Date	Description
0.1	Aug 31, 2017	Initial release
0.2	Nov 6, 2017	Updated Key Features (1.2)
0.3	Dec 13, 2017	Minor text update
0.4	Feb 1, 2018	Minor text update
0.5	Nov 30, 2018	Released the simplified edition

Table of Contents

1. Overview	5
1.1 Product Description	5
1.2 Key Features	5
1.3 Functional Description	7
1.4 Block Diagram	8
2. Ordering Information	9
2.1 Product Coding Rule	9
2.2 Top Marking.....	10

1. Overview

1.1 Product Description

The FerriSSD[®] is designed optimally for a wide range of embedded applications requiring faster access speed, small flexible form factor, and reliable SATA storage. By combining industry proven controller technology, NAND flash and passive components into a small single BGA package, FerriSSD[®] simplifies design efforts, reduces time-to-market while protecting from NAND technology migration concerns.

The new generation FerriSSD Dx series with 3D NAND Flash leveraging Silicon Motion's advanced technologies, including IntelligentScan[™], DataRefresh[™], high bandwidth LDPC code correction with proprietary RAID engine, and end-to-end data path protection to provide unsurpassed data integrity in a non-volatile storage device. The DRAM FerriSSD stands for the ultimate storage solution for embedded computing devices such as navigation, thin-client, POS, MFP, telecommunications, factory automation, as well as varieties of server applications.

1.2 Key Features

- Host Interface
 - Industrial Standard SATA Revision 3.1 compliant
 - Industrial Standard ATA/ATAPI-8 and ACS-2 command compliant
 - Supports SATA interface rate of 6Gb/s (backward compatible to 1.5Gb/s and 3Gb/s)
 - Native Command Queuing up to 32 commands
 - SATA Device Sleep (DevSleep)
 - Data Set Management command (TRIM)
 - Supports 28-bit and 48-bit LBA (Logical Block Addressing) mode commands
- Robust Data Protection and Data Reliability
 - Advanced system level protection against unstable power supply
 - SRAM and DRAM ECC protection
 - End-to-end data path protection
 - Hardware LDPC ECC engine with hard-decision and soft-decision decoding
 - RAID engine offers additional level of data protection
 - Internal data shaping optimizes the data endurance
 - StaticDataRefresh and EarlyRetirement technologies ensure data integrity and prevent read disturbance
 - Early weak block retirement feature
 - PowerShield and DataPhoenix technologies support power-down data protection and recovery

- SSD Status Monitoring
 - Supports Self-Monitoring, Analysis, and Reporting Technology (S.M.A.R.T.) commands
- Advanced Global Wear Leveling
 - Fully utilizes all memory blocks across management units/die(s)
 - Maximizes product lifespan with minimal wear leveling and write amplification overhead
- Advanced Security
 - Supports ATA8 security feature set
- Architecture
 - 32-bit RISC CPU
 - High-efficiency 64-bit system bus
 - Automatic sleep and wake-up mechanism to save power
 - Built-in voltage detectors for power failure protection
 - Built-in temperature sensor for SSD temperature detection
 - Supports the JTAG interface and UART (RS-232) interface for on-system debug
- Optional digitally signed firmware with eFuse for added firmware upgrade security
- Easy-to-Use
 - The Plug & Play device only requires format/fdisk prior to use
- Temperature Range
 - Commercial Operating Temperature: 0°C ~ 70°C
 - Extended Operating Temperature: -40°C ~ +85°C
 - Non-Operating and Storage Temperature: -55°C ~ +85°C
- Package
 - Small Form Factor: 16mm x 20mm
 - Green Package
 - RoHS Compliant

1.3 Functional Description

Data Transfer

The flash controller enables multi-way interleaving for multi-bank flash connection to obtain optimal performance. The FerriSSD uses a superior DMA technology to transfer data between the host and the NAND flash interface. The DMA technology transfers data at a very high rate in both directions (read and write) and in doing so, effectively decreases the loading of micro processor.

ECC Correction

The LDPC ECC engine executes parity generation and error detection/correction features, and enhances decoding throughput and data reliability. With LDPC of correction capability $1e-2$ RBER, the hard and soft decoding mechanism provides powerful error correction. Hence the FerriSSD can enhance the endurance and retention of SSD.

RAID Protection

In case of uncorrectable errors occurring within a superblock (a pre-defined area which consists of a particular set of blocks across physical NAND units), the RAID engine recovers the uncorrectable error chunk by using a certain storage space of parity bits. Incorporated with LDPC, the RAID ensures a comprehensive level of data integrity while providing a broad range of RAID overhead protection.

SMART and Data Security

The FerriSSD supports SMART commands that allow users to read spare and bad block information. The users can thus evaluate drive health at run time and receive an early warning before the flash drive lifespan ends. In addition, the users can use security commands to lock and unlock the drive by password or a hardware switch and protect sensitive data stored in the SSD.

Power Management

The FerriSSD supports SATA DEVSLP to greatly save power consumption. In addition, the embedded PLL circuits run the system clock and the frequency can be programmed to fit different NAND flash timings. With the power-on reset (POR) circuit, the SSD provides a reset signal for the core logic after power on.

1.4 Block Diagram

Figure 1: FerriSSD Block Diagram

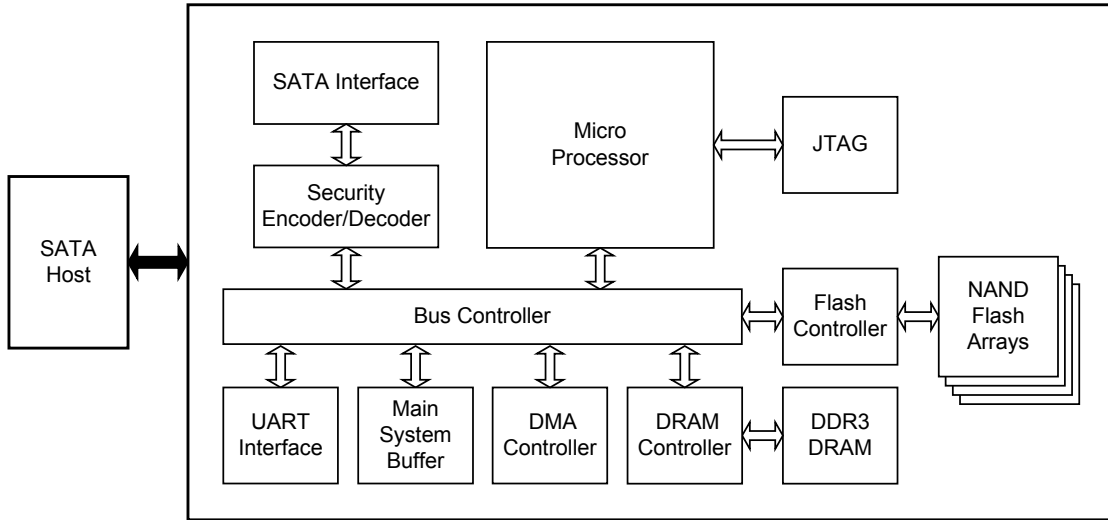

2. Ordering Information

2.1 Product Coding Rule

Table 1: Product Code Definitions

Example: SM 6 1 9 G E E □ DE □	
SM	Silicon Motion
6	Ferri Family
1	SATA Interface
9	9 = Embedded DRAM
G	Package: MCM TFBGA
E	Operating Temperature <ul style="list-style-type: none"> • X = 0°C ~ 70°C (C-temp) • E = -40°C ~ +85°C (I-temp) • A = -40°C ~ +85°C °C (Automotive AEC-Q100 Grade 3)
E	Capacity <ul style="list-style-type: none"> • A = 16GB • B = 32GB • C = 64GB • D = 128GB • E = 256GB
□	Blank (Reserved)
DE	Product Revision
□	Blank ('T' or 'S' for specified NAND vendor)

Note: See FerriSSD Product Selection Guide for specific ordering numbers.

2.2 Top Marking

Figure 2: FerriSSD Top Marking (Example)

