

PART NUMBER	REVISION	DESCRIPTION	FEED TYPE
2151443-2	J	FINE CRIMP HEIGHT ADJUST	PNEUMATIC
5-2151443-2	J	SEAL STRIPPER CRIMPER TERMINATING UNIT	PNEUMATIC
7-2151443-2	J	PNEUMATIC AND CRIMP TOOLING KIT	PNEUMATIC
7-2151443-7	J	CRIMP TOOLING KIT	-

ATLANTIC VERSION TERMINATOR INTERFACE ADAPTER

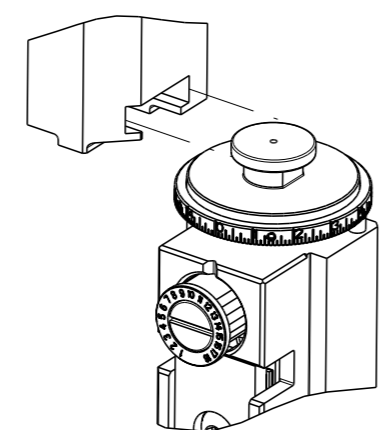

APPLICATOR DATA		
CRIMP	SIZE	TYPE
WIRE	0.80 mm [.031]	F
INSUL	0.85 mm [.033]	F

APPLICATOR INSTRUCTIONS
408-35042

TERMINAL DATA: MOLEX TERMINAL		MOLEX CRIMP SPECIFICATION	
TERMINAL NAME: 1.25 WIRE TO BOARD CONN, CRIMP RECEPT.			
WIRE STRIP LENGTH		INSULATION DIAMETER RANGE	
1.40-1.90 mm [.055-.075 IN]		∅0.51-0.99 mm [.020-.039 IN]	
TERMINAL APPLICATION SPECIFICATION	SPEC 63900-3700 Rev D		
TERMINALS APPLIED			
TE TERMINAL	MOLEX TERMINAL	TE TERMINAL	MOLEX TERMINAL
993820-1	50079-8000		

TERMINAL DATA: MOLEX TERMINAL		MOLEX CRIMP SPECIFICATION	
TERMINAL NAME: 1.25 WIRE TO BOARD CONN, CRIMP RECEPT.			
WIRE STRIP LENGTH		INSULATION DIAMETER RANGE	
1.40-1.90 mm [.055-.075 IN]		∅0.51-0.99 mm [.020-.039 IN]	
TERMINAL APPLICATION SPECIFICATION	SPEC 63900-3700 Rev D		
TERMINALS APPLIED			
TE TERMINAL	MOLEX TERMINAL	TE TERMINAL	MOLEX TERMINAL
993820-2	50058-8000		

WIRE SIZE	CRIMP HEIGHT mm [INCH]	CRIMP HEIGHT REFERENCE SETTING
26 AWG OR 0.12mm2	0.635+/-0.025 [.024+/- .001]	6.4
28 AWG OR 0.08mm2	0.585+/-0.025 [.023+/- .001]	6.9

WIRE SIZE	CRIMP HEIGHT mm [INCH]	CRIMP HEIGHT REFERENCE SETTING
28 AWG OR 0.08mm2	0.535+/-0.025 [.021+/- .001]	8.1
30 AWG OR 0.05mm2	0.505+/-0.025 [.020+/- .001]	8.4
32 AWG OR 0.03mm2	0.485+/-0.025 [.019+/- .001]	8.7

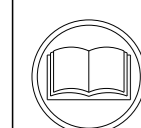

- 1 RECOMMENDED SPARE PARTS
- 2 REFER TO SUPPLIED INSTRUCTION SHEET FOR CLEANING, LUBRICATION AND STORAGE OF APPLICATOR.
- 3 APPLY PART NUMBER 2-23419-6 LOCTITE TO THREADS OF ITEM 242. APPLY PART NUMBER 1-23419-5 LOCTITE TO THREADS OF ITEM 180.
- 4 CRIMP HEIGHT REFERENCE SETTING WAS THE SETTING USED WHEN THE APPLICATOR WAS QUALIFIED AT THE FACTORY. ADJUSTMENT MAY BE NECESSARY WHEN RUNNING APPLICATOR IN THE FIELD.
- 5. UNLESS SPECIFIED OTHERWISE TORQUE VALUES SHALL BE USED PER DOCUMENT, 101-35000.
- 6 TERMINAL PITCH NOT COMPATIBLE WITH MECHANICAL FEED.
- 7 THIS APPLICATOR DOES NOT CUT CARRIER STRIP.
- 8. ADJUSTMENTS MAY BE REQUIRED WHEN CHANGING TERMINALS.
- 9 TERMINAL LUBRICANT IS RECOMMENDED.

***WARNING**
ON INSTALLATION, SET WIRE DISC TO CRIMP HEIGHT REFERENCE SETTING FOR LARGEST WIRE SIZE. CRIMP HEIGHT REFERENCE SETTINGS GREATER THAN THE VALUE SHOWN MAY CAUSE DAMAGE TO THE CRIMP TOOLING, REFER TO THE INSTRUCTION SHEET FOR PROPER SETUP AND ADJUSTMENTS.

REVISIONS					
#	LY#	DESCRIPTION	DATE	OWN	APVD
G		ECR-19-2151443	25JUN2019	JAH	TE
H		ECR-19-017381	08NOV2019	TB	TE
J		ECR-20-011293	10AUG2020	JWC	GB

-	-	1	-	1803515-3	RAM ASSEMBLY, SF ATLANTIC	293	
-	-	1	-	2-1803583-1	APPLICATOR BASIC ASSEMBLY, SF	292	
-	2	2	2	22281-8	SPRING, COMPRESSION	279	
-	2	2	2	2-18032-5	SCR, SET, FLT PNT, M5 X 20.0	278	
-	1	1	1	1-22281-8	SPRING, COMPRESSION	277	
-	1	1	1	2168083-6	SCR, SKT HD CAP, RoHS, M5 X 65	276	
-	1	1	1	980371-4	SCR, SKT HD SHLDR 5.0 DIA X 6.0	275	
-	1	1	1	356835-1	LEVER, DRAG RELEASE	274	
-	1	1	1	240792-1	DRAG, TERMINAL	273	
-	2	2	2	2168083-1	SCR, SKT HD CAP, RoHS, M3 X 8.0	271	
-	1	1	1	1-690438-0	FRONT STRIP GUIDE	270	
-	1	1	1	2119641-1	FEED CAM, AIR FEED	248	
-	1	1	1	2119082-1	CAM, SNAIL, INSULATION ADJUSTMENT	244	
-	1	1	1	2079764-1	WASHER, WAVE SPRING, CREST-TO-CREST	243	
-	1	1	1	2119083-1	RETAINER, INSULATION DIAL	242	
-	1	1	1	2844940-1	AIR FEED MODULE	238	
-	-	1	-	1803237-1	STRIPPER, SIDE FEED	182	
-	-	1	-	1-5018030-0	NUT, HEX, REG, RoHS, M3.5	181	
-	-	1	-	1-1752354-5	STANDOFF, HOLD-DOWN	180	
-	-	1	-	9931111-1	PIN, SLOTTED SPRING 3.0 X 20.0	177	
-	-	1	-	5-22280-0	SPRING, COMPRESSION	176	
-	-	1	-	1752353-3	GUIDE PIN, HOLDDOWN	175	
-	-	1	-	1901680-2	GUIDE PIN, HOLDDOWN	174	
-	REF	REF	REF	994970-2	COUNTER, MAGNETIC	164	
-	1	1	1	2119955-1	ASSY, LUBRICATOR, SIDE FEED	113	
-	1	1	1	2844908-1	SCREW, LOCKING	99	
-	1	1	1	2844907-1	POST, LOCKING	98	
-	1	1	1	1803607-3	DOCUMENTATION PACKAGE	71	
-	1	1	1	2-2119791-2	DEPRESSOR, WIRE	70	
-	1	1	1	2119740-1	TAG, IDENTIFICATION	67	
-	2	2	2	2168078-1	SCREW, DRIVE, RH, RoHS, 2 x .188	66	
-	1	1	1	2168083-2	SCR, SKT HD CAP, RoHS, M4 X 8.0	60	
-	1	1	1	5-18022-5	SCR, HEX HD CAP, M4 X 6.0	59	
-	1	1	1	1338685-1	PAWL, FEED	56	
-	4	4	4	2168083-3	SCR, SKT HD CAP, RoHS, M4 X 12.0	54	
-	1	1	1	18023-9	SCR, SKT HD CAP M4 X 6.0	49	
-	1	-	1	1803583-9	APPLICATOR BASIC ASSEMBLY, SF	46	
-	1	-	1	1803515-1	RAM ASSEMBLY, SF ATLANTIC	44	
-	1	1	1	1803602-1	SCR, BHSC, RoHS (M8 X 25)	41	
-	1	1	1	2-1752356-6	SUPPORT, TERMINAL	34	
-	2	2	2	2079383-5	SCR, BHSC, RoHS (M4 X 20)	33	
-	2	2	2	2-2844962-3	SPACER, CYLINDRICAL, STRIP GUIDE	30	
-	1	1	1	2-2844938-0	PLATE, STRIP GUIDE	29	
-	1	1	1	1320928-2	STRIP GUIDE	24	
-	1	-	1	2168083-2	SCR, SKT HD CAP, RoHS, M4 X 8.0	21	
-	2	1	2	1-18028-2	WASHER, FLAT, REG M4	20	
-	1	-	1	2119533-3	STRIPPER, SIDE FEED	19	
-	1	1	1	3-22280-3	SPRING, COMPRESSION	12	
-	1	1	1	1-356885-5	STOP, SHEAR	11	
-	1	1	1	2119805-1	SHEAR HOLDER, FRONT	10	
-	1	1	1	1803095-6	FLOATING SHEAR, FRONT	9	
-	1	2	1	1	4-1633621-5	ANVIL, COMBINATION	8
-	-	-	-	-	-	7	
-	-	-	-	-	-	6	
-	1	1	1	2-2119757-2	DEPRESSOR, SHEAR	5	
-	1	1	1	2-238011-5	BLOCK, CRIMPER SPACER	4	
-	1	2	1	1	1803167-5	CRIMPER, INSULATION F SPECIAL	3
-	1	1	1	455888-1	SPACER, CRIMPER	2	
-	1	2	1	1	5-1803407-6	CRIMPER, WIRE PREMIUM	1

THIS DRAWING IS A CONTROLLED DOCUMENT.		OWN: X ZHAO 25MAY2012	TE Connectivity
		CHK: T ELBIN 25MAY2012	
DIMENSIONS:	TOLERANCES UNLESS OTHERWISE SPECIFIED:	APVD: S XI 25MAY2012	NAME: Ocean Side Feed Applicator
mm	0 PLC ± 1 PLC ± 2 PLC ± 3 PLC ± 4 PLC ±	PRODUCT SPEC	
MATERIAL		APPLICATION SPEC	SIZE: CAGE CODE DRAWING NO
		FINISH	RESTRICTED TO
		WEIGHT	A100779C=2151443
		CUSTOMER DRAWING	SCALE: 1:2 SHEET 1 OF 4 REV J

ATLANTIC VERSION
Shown on sheets 1 of 4 & 2 of 4
(Pacific version shown on sheets 3 of 4 & 4 of 4)

REVISIONS				
P	LY#	DESCRIPTION	DATE	OWN
-	-	SEE SHEET 1	-	-

FEED TYPE

PNEUMATIC

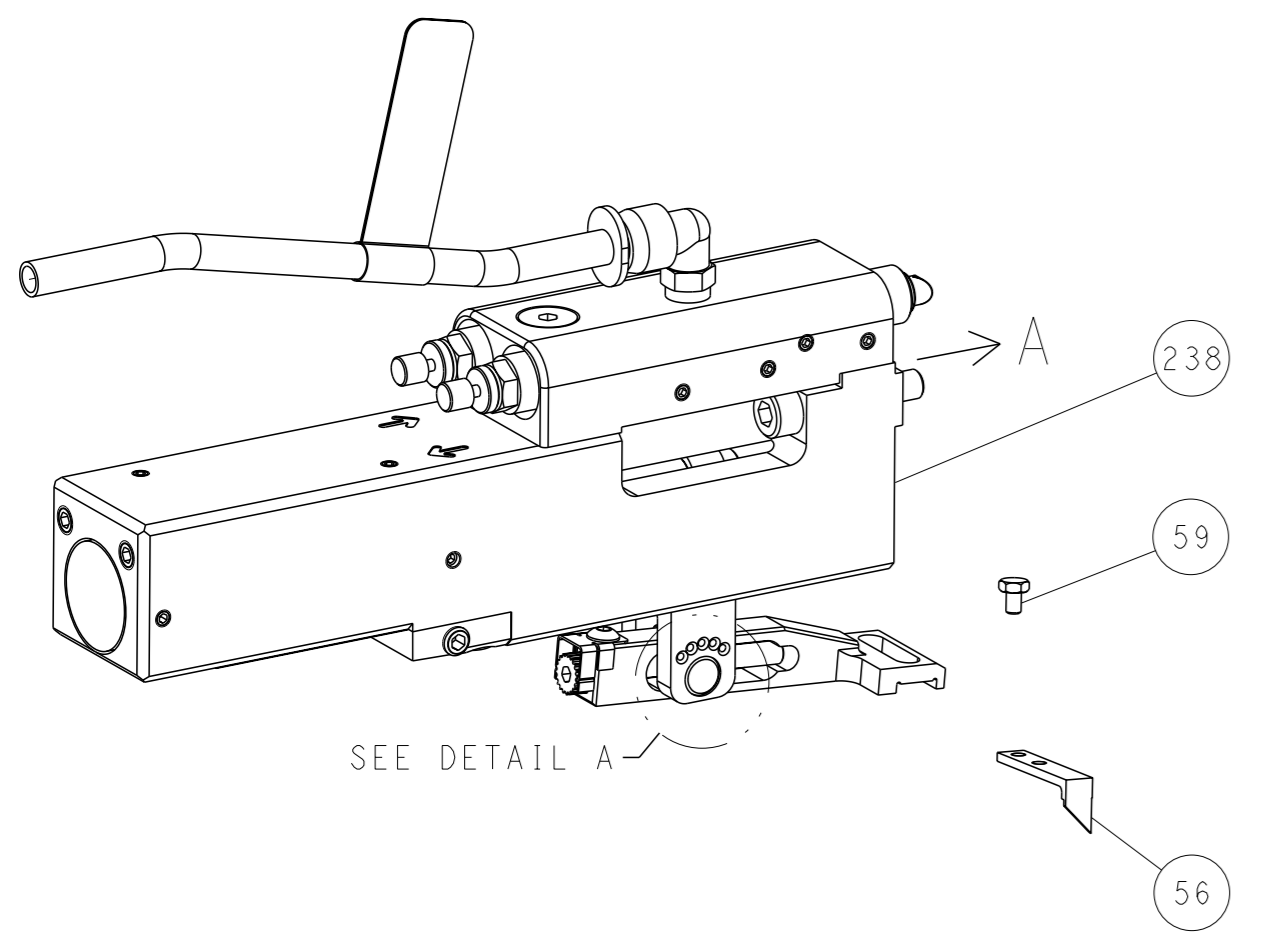

FEED SPRING SETTING POSITION (SHOWN FROM REAR SIDE)

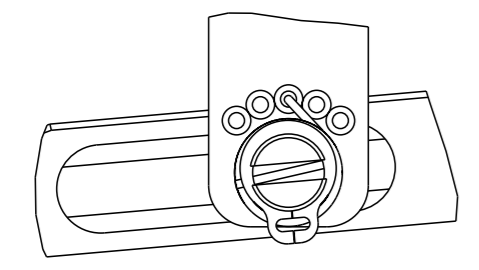

DETAIL A

CAM POSITION

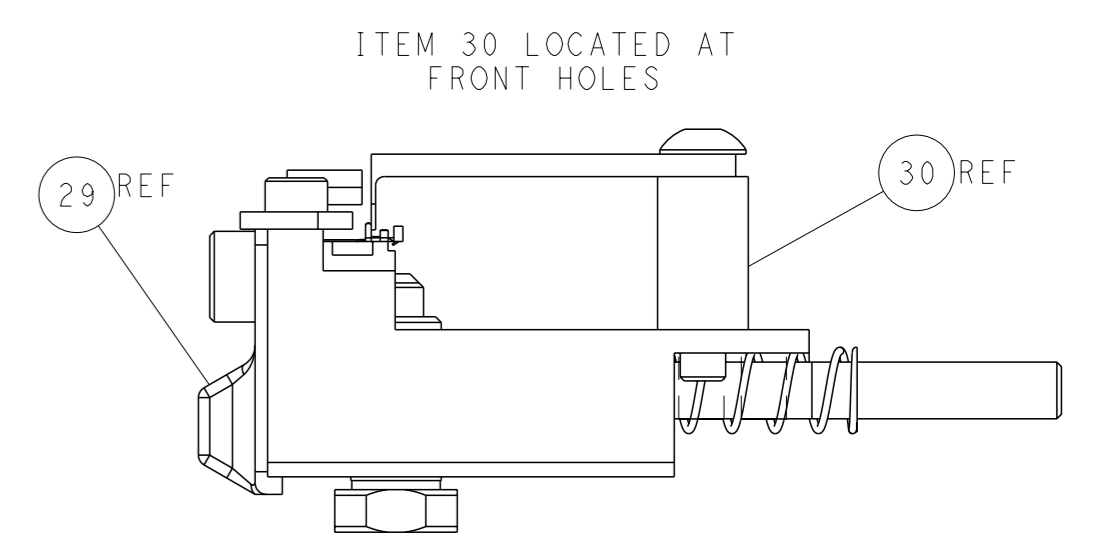
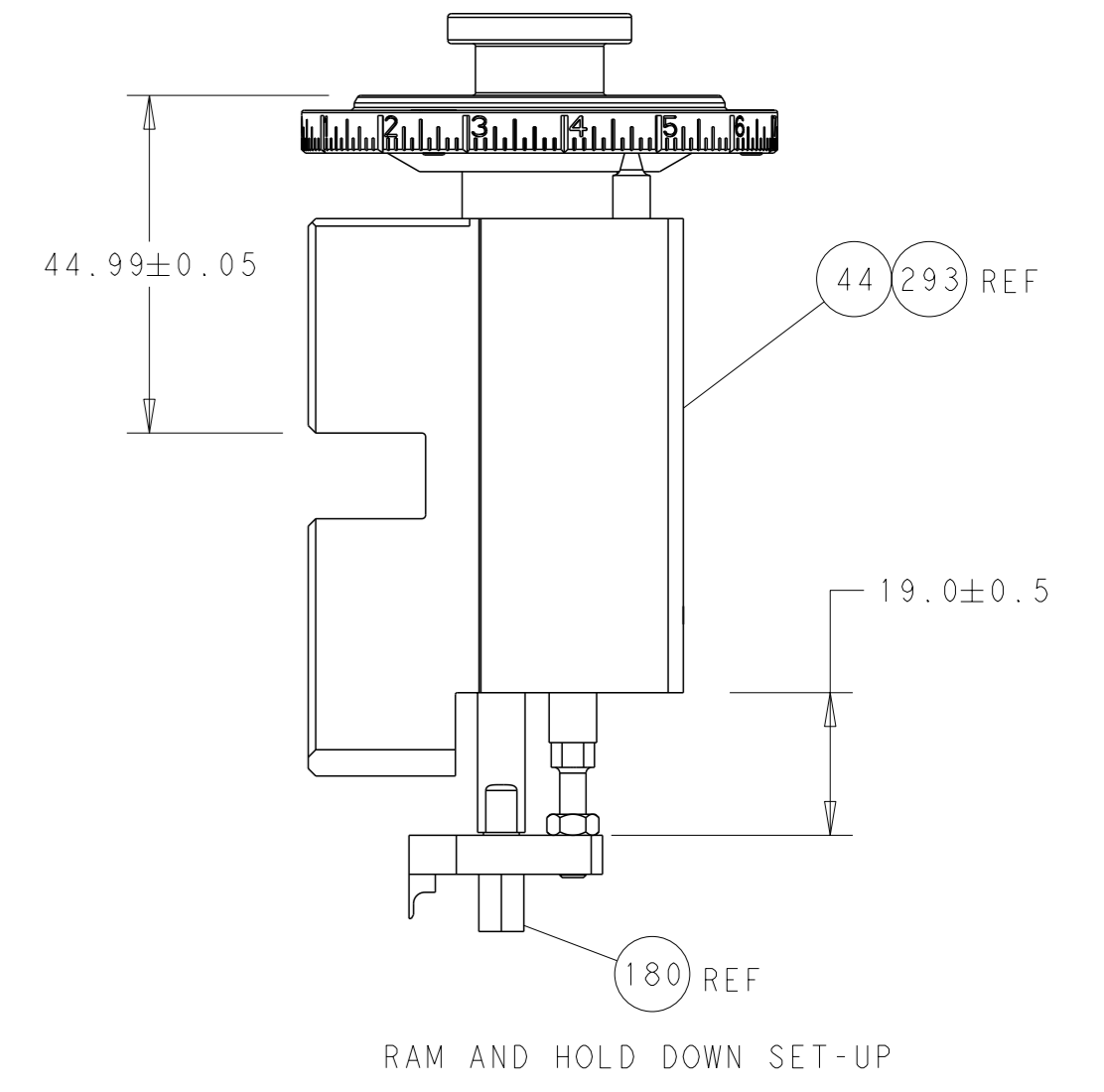
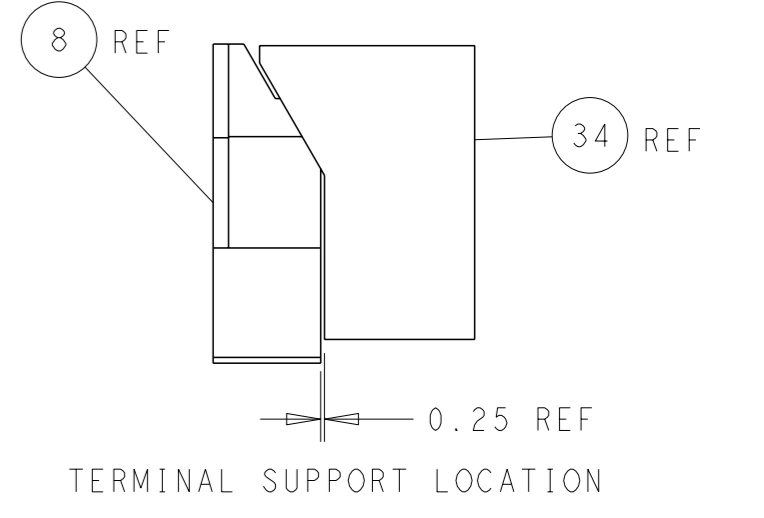
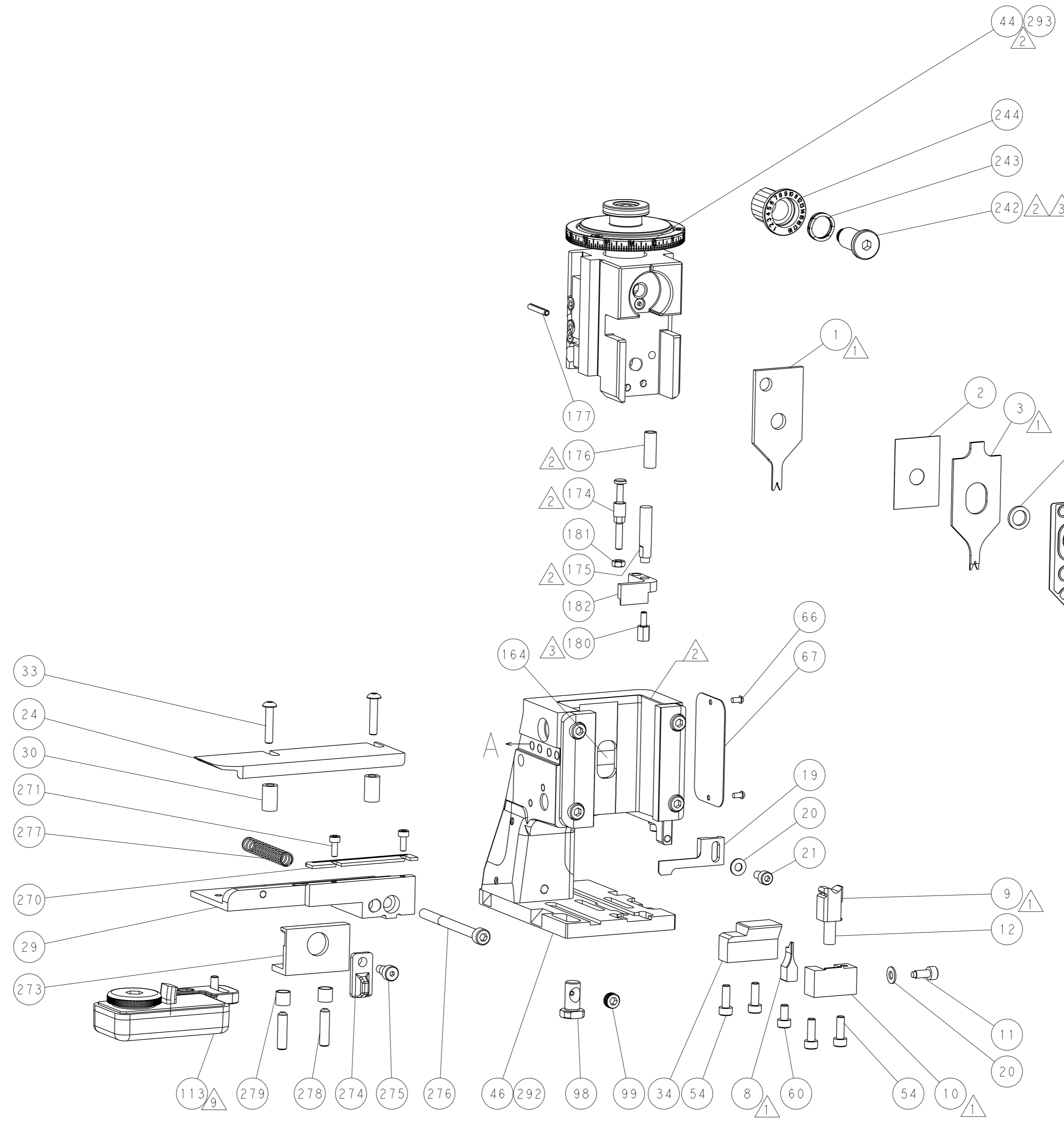
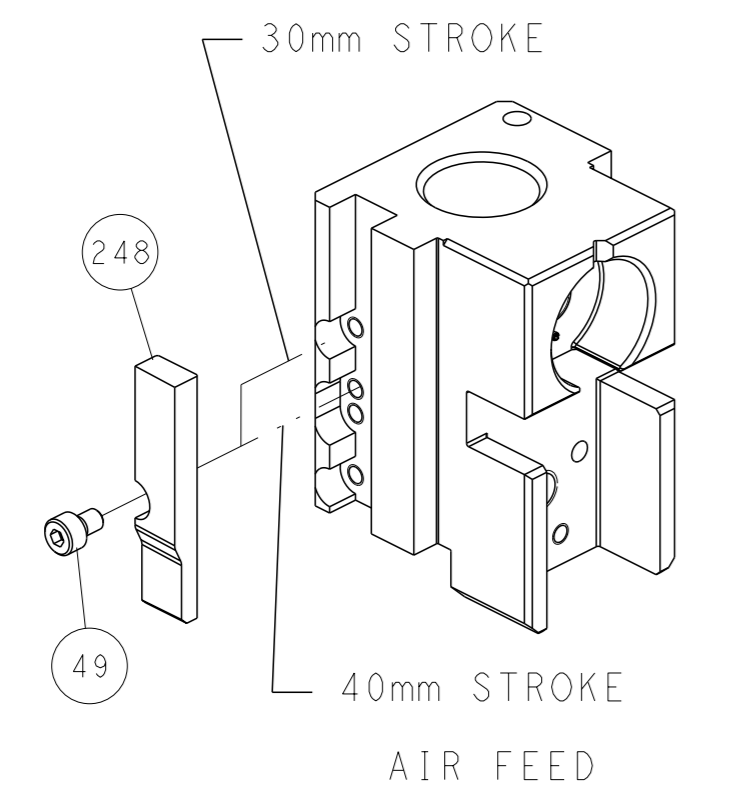

ATLANTIC VERSION
 Shown on sheets 1 of 4 & 2 of 4
 (Pacific version shown on sheets 3 of 4 & 4 of 4)

THIS DRAWING IS A CONTROLLED DOCUMENT.		OWN: X_ZHAO 25MAY2012	 TE Connectivity
DIMENSIONS: mm		CHK: T_ELBIN 25MAY2012	
TOLERANCES UNLESS OTHERWISE SPECIFIED:		APVD: S_XI 25MAY2012	
0 PLC ± 1 PLC ± 2 PLC ± 3 PLC ± 4 PLC ± ANGLES FINISH ±		NAME: Ocean Side Feed Applicator	
MATERIAL: -	FINISH: -	WEIGHT: -	SIZE: A 00779 C=2151443
CUSTOMER DRAWING		SCALE: 1:2	SHEET 2 OF 4 REV J

PART NUMBER	REVISION	DESCRIPTION	FEED TYPE
2-2151443-2	J	FINE CRIMP HEIGHT ADJUST	PNEUMATIC
7-2151443-7	J	CRIMP TOOLING KIT	-

PACIFIC VERSION TERMINATOR
INTERFACE ADAPTER

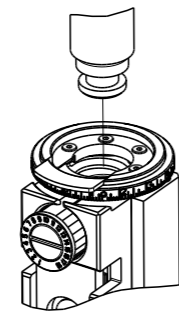

REVISIONS				
#	LY#	DESCRIPTION	DATE	OWN
-	-	SEE SHEET 1	-	-

APPLICATOR DATA		
CRIMP	SIZE	TYPE
WIRE	0.80 mm [.031]	F
INSUL	0.85 mm [.033]	F

APPLICATOR INSTRUCTIONS
408-35042

TERMINAL DATA: MOLEX TERMINAL		MOLEX CRIMP SPECIFICATION	
TERMINAL NAME: 1.25 WIRE TO BOARD CONN, CRIMP RECEPT.			
WIRE STRIP LENGTH		INSULATION DIAMETER RANGE	
1.40-1.90 mm [.055-.075 IN]		∅0.51-0.99 mm [.020-.039 IN]	
TERMINAL APPLICATION SPECIFICATION	SPEC 63900-3700 Rev D	-	-
TERMINALS APPLIED			
TE TERMINAL	MOLEX TERMINAL	TE TERMINAL	MOLEX TERMINAL
993820-1	50079-8000		

TERMINAL DATA: MOLEX TERMINAL		MOLEX CRIMP SPECIFICATION	
TERMINAL NAME: 1.25 WIRE TO BOARD CONN, CRIMP RECEPT.			
WIRE STRIP LENGTH		INSULATION DIAMETER RANGE	
1.40-1.90 mm [.055-.075 IN]		∅0.51-0.99 mm [.020-.039 IN]	
TERMINAL APPLICATION SPECIFICATION	SPEC 63900-3700 Rev D	-	-
TERMINALS APPLIED			
TE TERMINAL	MOLEX TERMINAL	TE TERMINAL	MOLEX TERMINAL
993820-2	50058-8000		

WIRE SIZE	CRIMP HEIGHT mm [INCH]	CRIMP HEIGHT REFERENCE SETTING
26 AWG OR 0.12mm2	0.625+/-0.025 [.024+/- .001]	6.4
28 AWG OR 0.08mm2	0.585+/-0.025 [.023+/- .001]	6.9

WIRE SIZE	CRIMP HEIGHT mm [INCH]	CRIMP HEIGHT REFERENCE SETTING
28 AWG OR 0.08mm2	0.535+/-0.025 [.021+/- .001]	8.1
30 AWG OR 0.05mm2	0.505+/-0.025 [.020+/- .001]	8.4
32 AWG OR 0.03mm2	0.485+/-0.025 [.019+/- .001]	8.7

-	2	22281-8	SPRING, COMPRESSION	279	
-	2	2-18032-5	SCR, SET, FLT PNT, M5 X 20.0	278	
-	1	1-22281-8	SPRING, COMPRESSION	277	
-	1	2168083-6	SCR, SKT HD CAP, RoHS, M5 X 6.5	276	
-	1	980371-4	SCR, SKT HD SHLDR 5.0 DIA X 6.0	275	
-	1	356835-1	LEVER, DRAG RELEASE	274	
-	1	240792-1	DRAG, TERMINAL	273	
-	2	2168083-1	SCR, SKT HD CAP, RoHS, M3 X 8.0	271	
-	1	1-690438-0	FRONT STRIP GUIDE	270	
-	1	2119082-1	CAM, SNAIL, INSULATION ADJUSTMENT	244	
-	1	2079764-1	WASHER, WAVE SPRING, CREST-TO-CREST	243	
-	1	2119083-1	RETAINER, INSULATION DIAL	242	
-	1	2844940-1	AIR FEED MODULE	238	
-	REF	994970-2	COUNTER, MAGNETIC	164	
-	1	2119641-2	FEED CAM, AIR FEED	151	
-	1	2168083-8	SCR, SKT HD CAP, RoHS, M4 X 16	144	
-	4	2168083-9	SCR, SKT HD CAP, RoHS, M4 X 20	143	
-	1	1-1803583-0	APPLICATOR BASIC ASSEMBLY, SF	141	
-	1	1803516-1	RAM ASSEMBLY, SF PACIFIC	140	
-	1	2119955-1	ASSY, LUBRICATOR, SIDE FEED	113	
-	1	2844908-1	SCREW, LOCKING	99	
-	1	2844907-1	POST, LOCKING	98	
-	1	1803607-3	DOCUMENTATION PACKAGE	71	
-	1	2-2119791-2	DEPRESSOR, WIRE	70	
-	1	2119740-1	TAG, IDENTIFICATION	67	
-	2	2168078-1	SCREW, DRIVE, RH, RoHS, 2 x .188	66	
-	1	5-18022-5	SCR, HEX HD CAP, M4 X 6.0	59	
-	1	1338685-1	PAWL, FEED	56	
-	1	18023-9	SCR, SKT HD CAP M4 X 6.0	49	
-	1	1803602-1	SCR, BHSC, RoHS (M8 X 25)	41	
-	1	2-1752356-6	SUPPORT, TERMINAL	34	
-	2	2079383-5	SCR, BHSC, RoHS (M4 X 20)	33	
-	2	2-2844962-3	SPACER, CYLINDRICAL, STRIP GUIDE	30	
-	1	2-2844938-0	PLATE, STRIP GUIDE	29	
-	1	1320928-2	STRIP GUIDE	24	
-	1	2168083-2	SCR, SKT HD CAP, RoHS, M4 X 8.0	21	
-	2	1-18028-2	WASHER, FLAT, REG M4	20	
-	1	2119533-3	STRIPPER, SIDE FEED	19	
-	1	3-22280-3	SPRING, COMPRESSION	12	
-	1	1-356885-5	STOP, SHEAR	11	
-	1	2119805-1	SHEAR HOLDER, FRONT	10	
-	1	1803095-6	FLOATING SHEAR, FRONT	9	
-	1	4-1633621-5	ANVIL, COMBINATION	8	
-	-	-	-	7	
-	-	-	-	6	
-	1	2-2119757-2	DEPRESSOR, SHEAR	5	
-	1	2-238011-5	BLOCK, CRIMPER SPACER	4	
-	1	1803167-5	CRIMPER, INSULATION F SPECIAL	3	
-	1	455888-1	SPACER, CRIMPER	2	
-	1	5-1803407-6	CRIMPER, WIRE PREMIUM	1	
-	77	-22	PART NO	DESCRIPTION	ITEM NO



- 1 RECOMMENDED SPARE PARTS
- 2 REFER TO SUPPLIED INSTRUCTION SHEET FOR CLEANING, LUBRICATION AND STORAGE OF APPLICATOR.
- 3 APPLY PART NUMBER 2-23419-6 LOCTITE TO THREADS OF ITEM 242.
- 4 CRIMP HEIGHT REFERENCE SETTING WAS THE SETTING USED WHEN THE APPLICATOR WAS QUALIFIED AT THE FACTORY. ADJUSTMENT MAY BE NECESSARY WHEN RUNNING APPLICATOR IN THE FIELD.
5. UNLESS SPECIFIED OTHERWISE TORQUE VALUES SHALL BE USED PER DOCUMENT, 101-35000.
- 6 TERMINAL PITCH NOT COMPATIBLE WITH MECHANICAL FEED.
- 7 THIS APPLICATOR DOES NOT CUT CARRIER STRIP.
8. ADJUSTMENTS MAY BE REQUIRED WHEN CHANGING TERMINALS.
- 9 TERMINAL LUBRICANT IS RECOMMENDED.

***WARNING**
ON INSTALLATION, SET WIRE DISC TO CRIMP HEIGHT REFERENCE SETTING FOR LARGEST WIRE SIZE. CRIMP HEIGHT REFERENCE SETTINGS GREATER THAN THE VALUE SHOWN MAY CAUSE DAMAGE TO THE CRIMP TOOLING, REFER TO THE INSTRUCTION SHEET FOR PROPER SETUP AND ADJUSTMENTS.

PACIFIC VERSION
Shown on sheets 3 of 4 & 4 of 4
(Atlantic version shown on sheets 1 of 4 & 2 of 4)

THIS DRAWING IS A CONTROLLED DOCUMENT.		OWN X ZHAO 25MAY2012	TE Connectivity	
DIMENSIONS: mm		CHK T. ELBIN 25MAY2012	NAME Ocean Side Feed Applicator	
TOLERANCES UNLESS OTHERWISE SPECIFIED:		APVD S XI 25MAY2012	PRODUCT SPEC	
0 PLC ±		APPLICATION SPEC		
1 PLC ±		SIZE CAGE CODE DRAWING NO		
2 PLC ±		RESTRICTED TO		
3 PLC ±		A100779C=2151443		
4 PLC ±		SCALE 1:2 SHEET 3 OF 4 REV J		
ANGLES FINISH		CUSTOMER DRAWING		

REVISIONS				
P	LYR	DESCRIPTION	DATE	OWN / APVD
-	-	SEE SHEET 1	-	-

FEED TYPE PNEUMATIC

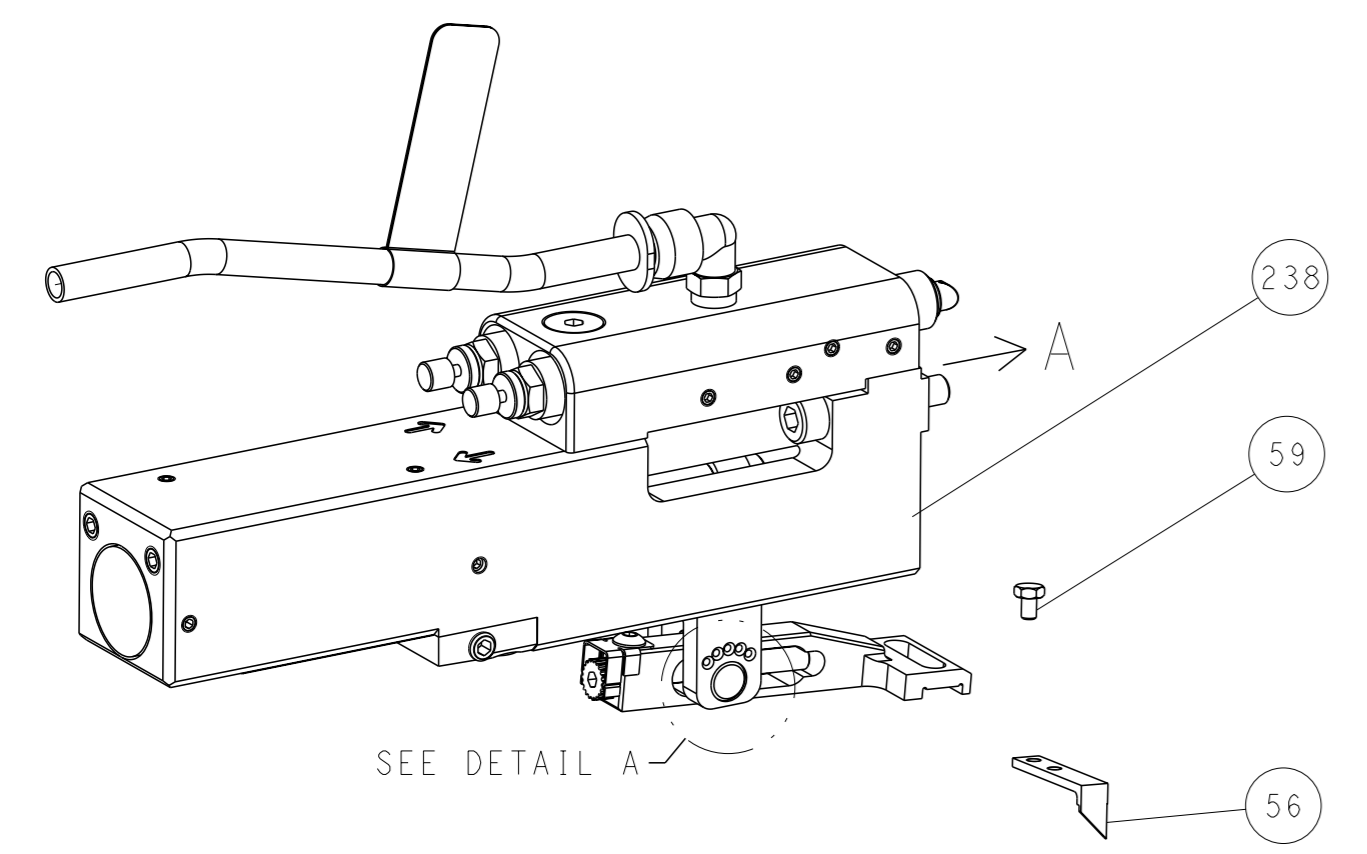

SEE DETAIL A

FEED SPRING SETTING POSITION (SHOWN FROM REAR SIDE)

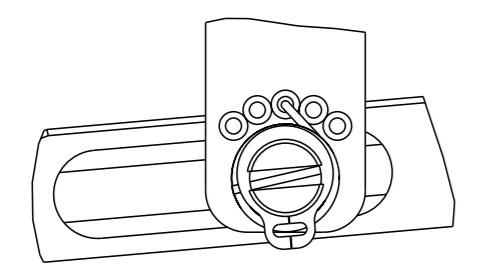

DETAIL A

CAM POSITION

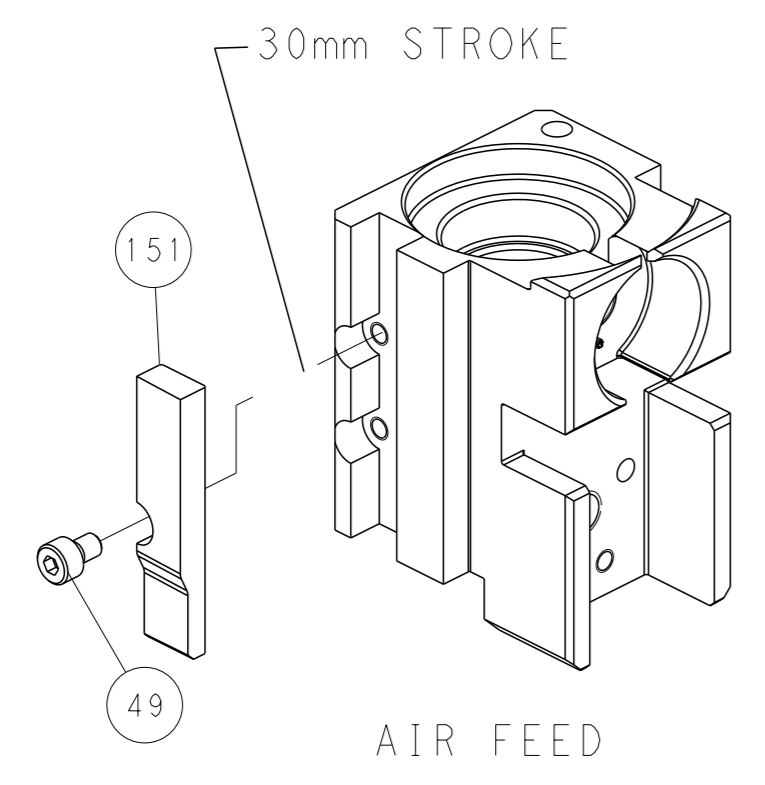

AIR FEED

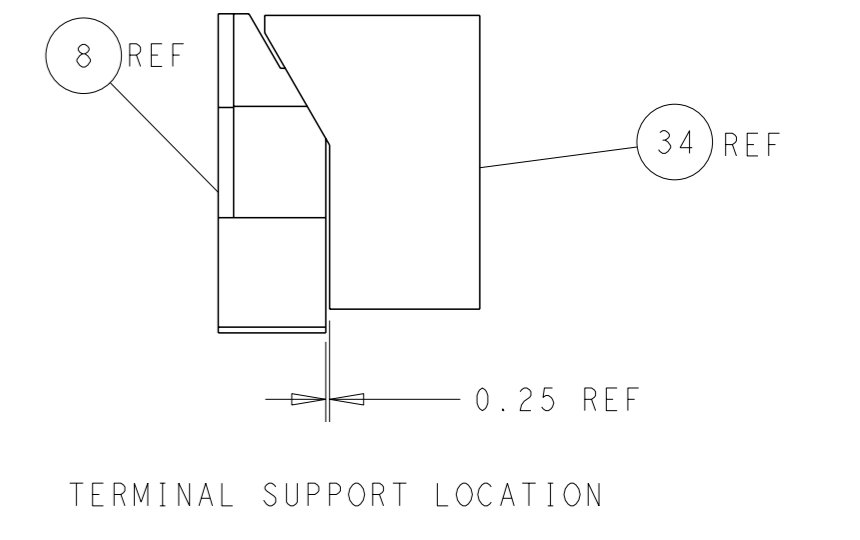
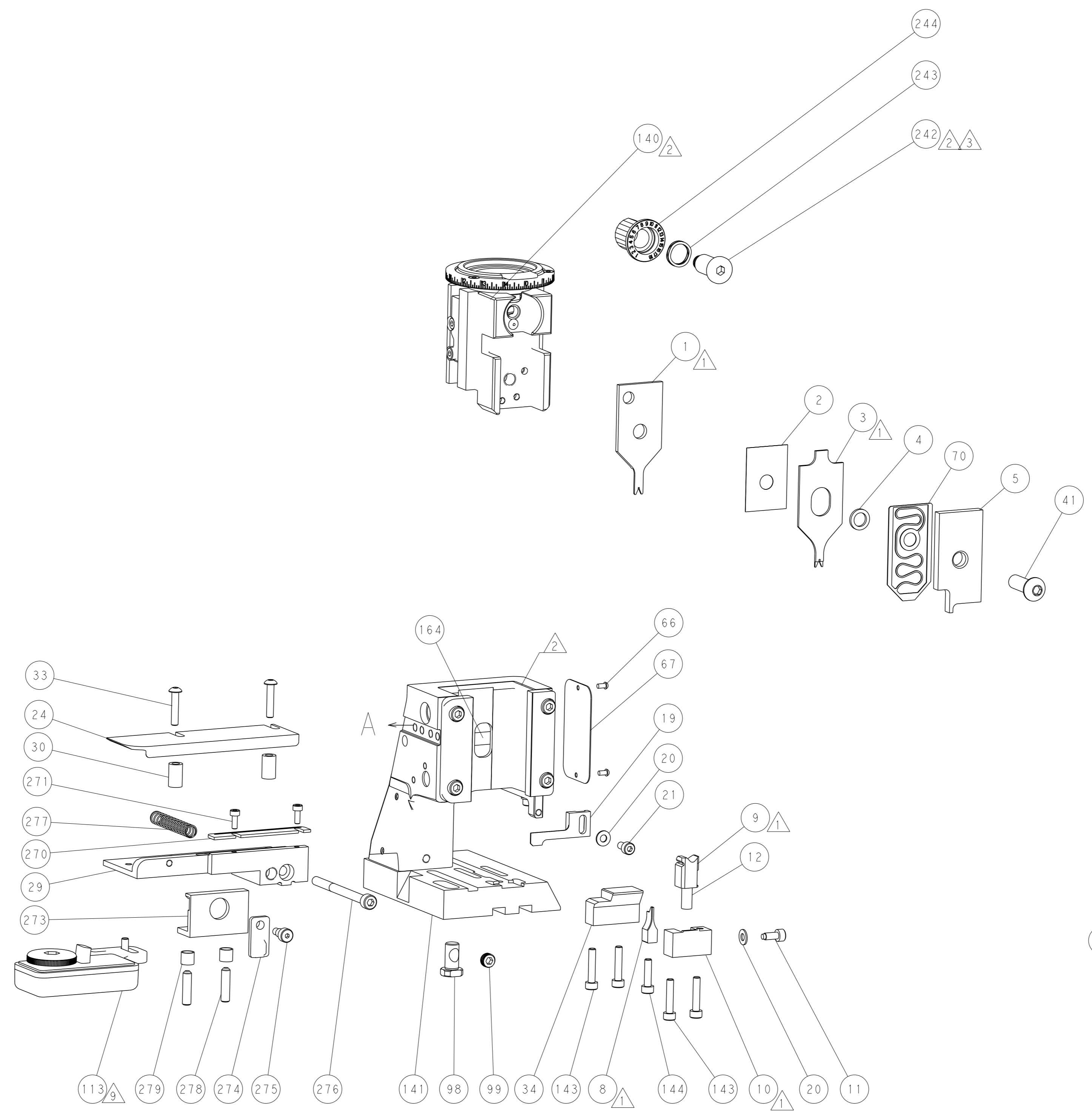

TERMINAL SUPPORT LOCATION

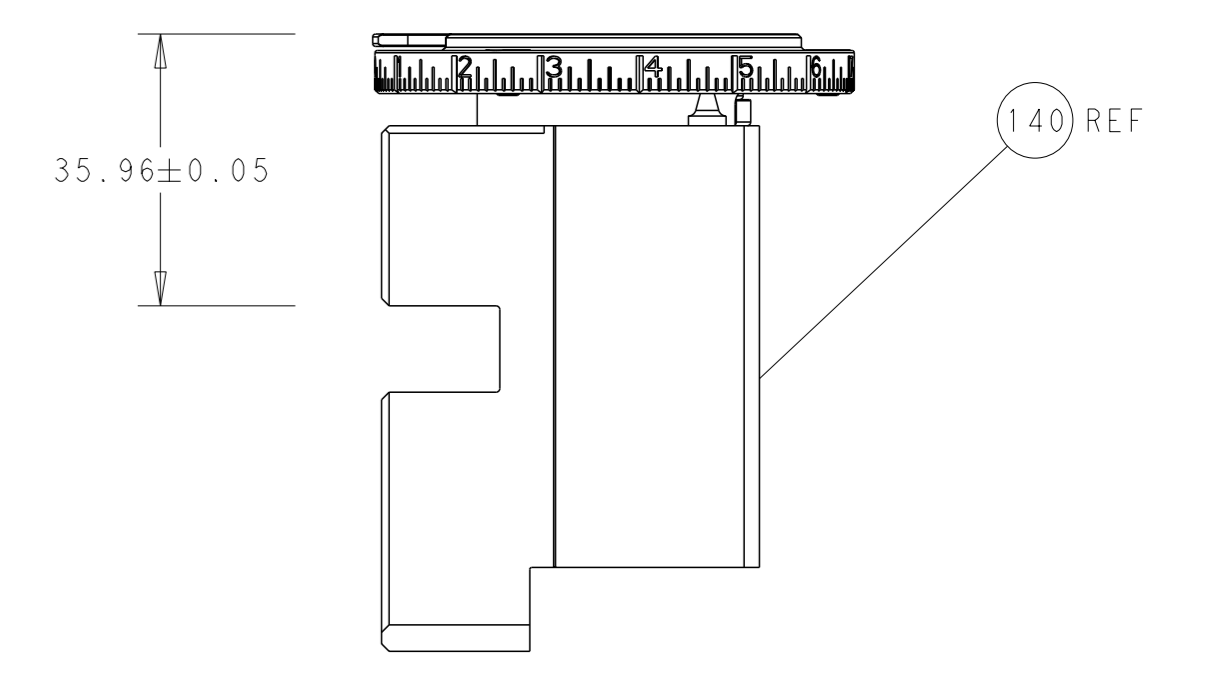

RAM SET-UP

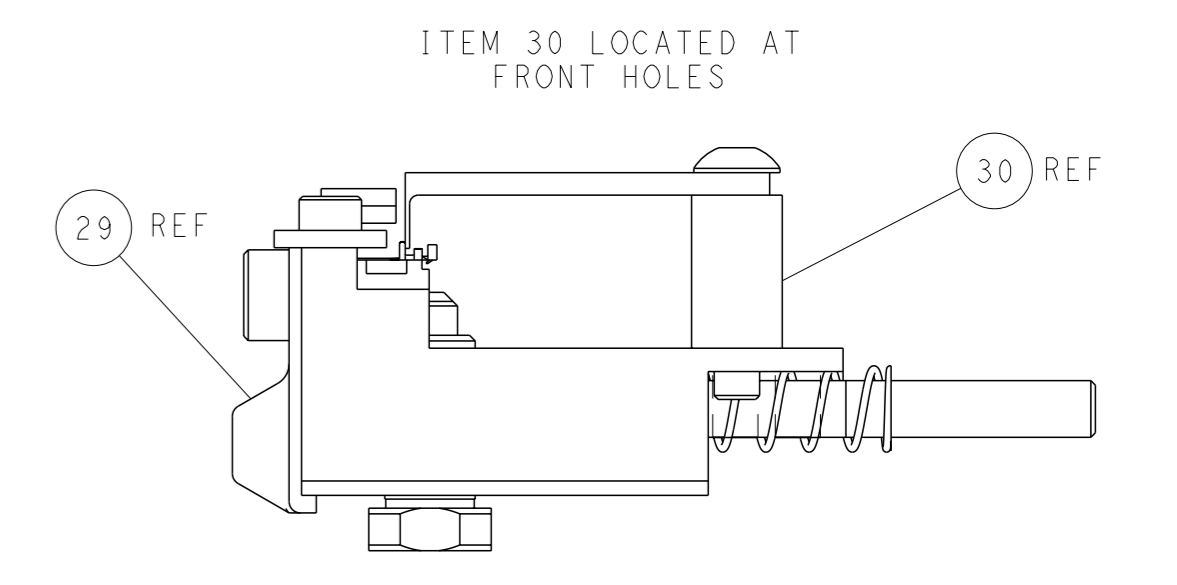

FEED TRACK POSITION
GUIDE BY INSULATION BARREL

PACIFIC VERSION
Shown on sheets 3 of 4 & 4 of 4
(Atlantic version shown on sheets 1 of 4 & 2 of 4)

THIS DRAWING IS A CONTROLLED DOCUMENT.		OWN: X_ZHAO	25MAY2012	TE TE Connectivity
		CHK: T_ELBIN	25MAY2012	
DIMENSIONS:		APVD: S_XI	25MAY2012	NAME: Ocean Side Feed Applicator
mm		PRODUCT SPEC		
TOLERANCES UNLESS OTHERWISE SPECIFIED:		APPLICATION SPEC		SIZE: CAGE CODE DRAWING NO. RESTRICTED TO
0 PLC ±		-		
1 PLC ±		-		A 00779 ©=2151443
2 PLC ±		-		
3 PLC ±		-		SCALE: 1:2 SHEET 4 OF 4 REV J
4 PLC ±		-		
ANGLES FINISH *		CUSTOMER DRAWING		