

CABLE PRINT - according to WN-00017
(Molex "Material-No" MXyyww)

Connector pin assignment
Plug M23 5+PE MA

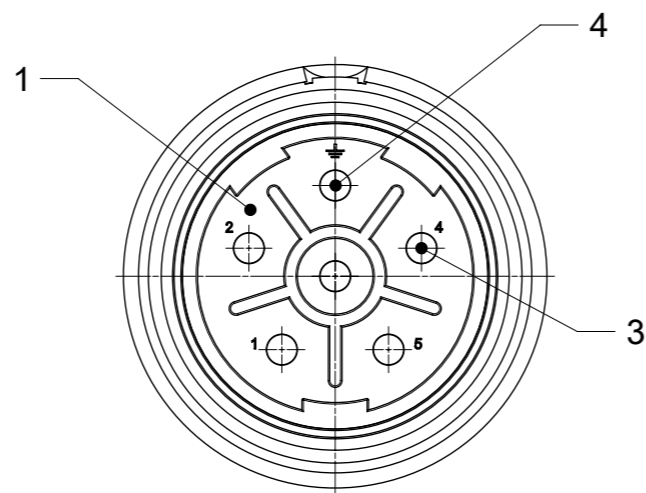

SCALE 2:1

Wiring Diagram
Connection: IN-LINE

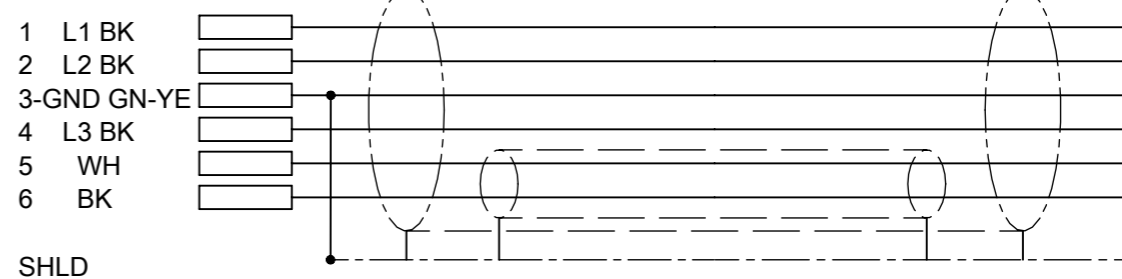

Technical Data:

Number of positions	5 + PE
Number of contacts	6
Contact Ø [mm]	2
Nominal current [A]	18
Nominal voltage [V~]	600
Degree of pollution 3	
Test voltage [V~]	3000
Max. contact resistance [mΩ]	3
Insulation resistance [MΩ]	> 10 ¹³
Protection	IP 67 (connected)
Temperature range (fixed)	-40°C to 90°C
Temperature range (flex)	-25°C to 80°C

Packaging:
The cordsets delivered packed into carton without PE-bag.

TABLE 1

MOLEX P/N	ENGINEERING No.	L [mm]	Tol.[mm]
1204800810	K0P6S06W01M005	500	+40
1204800532	K0P6S06W01M010	1000	+40
1204800533	K0P6S06W01M020	2000	+60
1204800534	K0P6S06W01M030	3000	+60
1204800535	K0P6S06W01M040	4000	+60
1204800536	K0P6S06W01M050	5000	+60
1204800537	K0P6S06W01M100	10000	+80
1204800538	K0P6S06W01M150	15000	+140
1204800539	K0P6S06W01M200	20000	+140

TABLE 2

POS	QTY	DESCRIPTION	MATERIAL	FINISH
1	1	INSERT M23 MA	PA	BLACK
2	1	SHELL M23 MA	BRASS	NICKEL PLATED
3	5	CONTACT 20 MA	COPPER ALLOY	GOLD OVER NICKEL
4	1	GROUNDING 20 MA	COPPER ALLOY	GOLD OVER NICKEL
5	1	GASKET OR	NBR	BLACK
6	1	OVERMOLD	TPU	BLACK
7	1	CABLE	WSOR	ORANGE

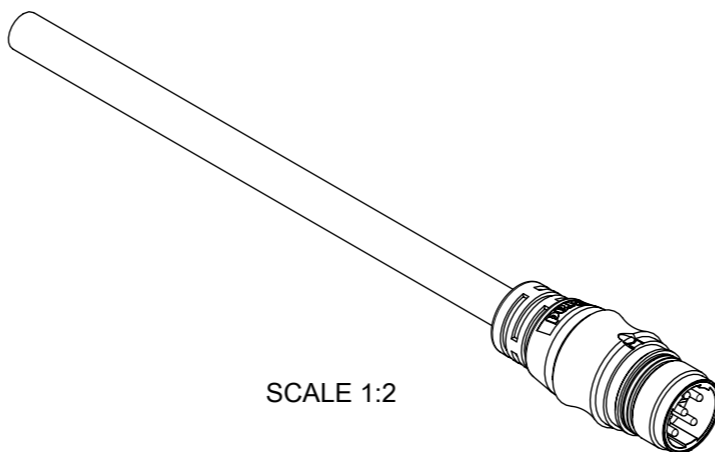

SCALE 1:2

FUNCTIONAL SYMBOLS ▽A = 0 ▽E = 0 ▽V = 0	THIS DRAWING CONTAINS INFORMATION THAT IS PROPRIETARY TO MOLEX ELECTRONIC TECHNOLOGIES, LLC AND SHOULD NOT BE USED WITHOUT WRITTEN PERMISSION	CURRENT REV DESC:		molex
	DIMENSION UNITS: mm SCALE: 1:1	GENERAL TOLERANCES (UNLESS SPECIFIED): ANGULAR TOL ± 1.0° 4 PLACES ± 3 PLACES ± 0.0 2 PLACES ± 0.05 1 PLACE ± 0.3 0 PLACES ± 0.5		
DIVISIONAL SYMBOLS	EC NO: 720467	DRWN: APWLAK01	2022/09/07	PRODUCT CUSTOMER DRAWING
	CHK'D: RSILLER	APPR: RSILLER	2022/09/08	
INITIAL REVISION:		DRWN: FGAIK	2015/12/01	DOC TYPE: PSD
DRAFT WHERE APPLICABLE MUST REMAIN WITHIN DIMENSIONS		APPR: RSILLER	2016/01/28	DOC PART: 000
THIRD ANGLE PROJECTION		DRAWING: A3-SIZE	SERIES: 120480	REVISION: B
MATERIAL NUMBER: see table 1		CUSTOMER: GENERAL MARKET		SHEET NUMBER: 1 OF 1