

ISL21070

25µA Micropower Voltage References

FN7599
Rev 4.00
September 3, 2015

The ISL21070 voltage references are analog voltage references featuring low supply voltage operation at ultra-low 25µA max operating current.

Additionally, the ISL21070 family features guaranteed initial accuracy as low as ±0.2% and 30ppm/°C temperature coefficient.

These references are ideal for general purpose applications for performance at lower cost. The ISL21070 is provided in an industry standard 3 Ld SOT-23 pinout.

The ISL21070 offers output voltages that can be used as precision voltage sources for control loops, standby voltages for low power states for DSP, FPGA, Data path Controllers, Microcontrollers and other core voltages: 0.600V, 2.048V, and 2.5V.

Applications

- Battery management/monitoring
- Low power standby voltages
- Portable instrumentation
- Consumer/medical electronics
- Wearable Electronics
- Lower Cost industrial and instrumentation
- Power regulation circuits
- Control loops and compensation networks
- LED/diode supply

Features

- Reference output voltage 0.600V, 2.048V, 2.500V
- Initial accuracy: 0.600V ±1.0%
- Initial accuracy: 2.048V ±0.25%
- Initial accuracy: 2.5V ±0.2%
- Input voltage range
 - ISL21070-06 2.7V to 5.5V
 - ISL21070-20 2.7V to 5.5V
 - ISL21070-25 2.7V to 5.5V
- Output voltage noise 30µV_{P-P} (0.1Hz to 10Hz)
- Supply current 25µA (max)
- Tempco (0.600V only) 50ppm/°C
- Tempco (all others) 30ppm/°C
- Output current capability ±10mA
- Operating temperature range -40°C to +85°C
- Package 3 Ld SOT-23
- Pb-Free (RoHS compliant)

Related Literature

- [AN1533](#), “X-Ray Effects on Intersil FGA References”
- [AN1494](#), “Reflow and PC Board Assembly Effects on Intersil FGA References”

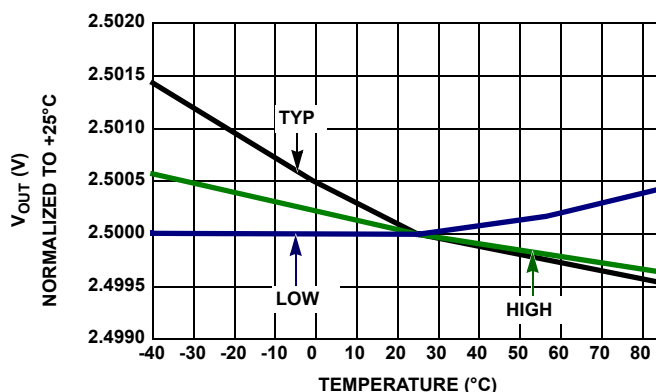
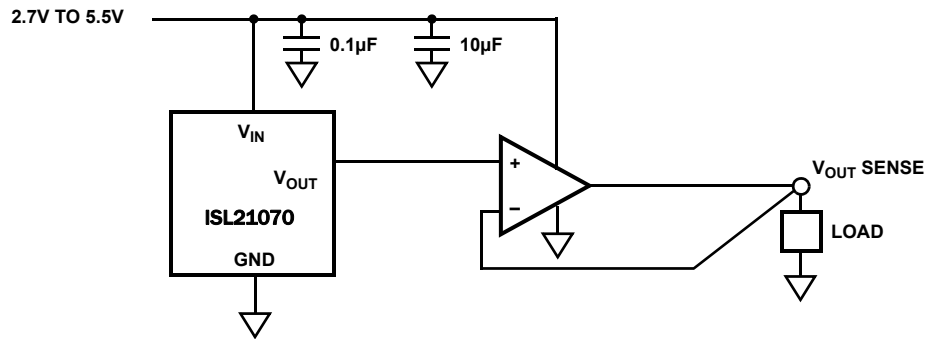
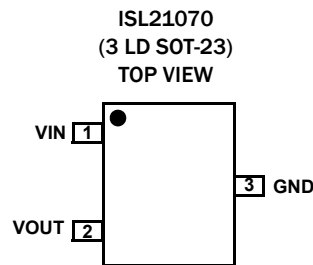

FIGURE 1. V_{OUT} vs TEMPERATURE NORMALIZED to +25°C

Typical Application Circuit



Pin Configuration



Pin Descriptions

| PIN NUMBER | PIN NAME | DESCRIPTION |
|------------|----------|--|
| 1 | VIN | Input Voltage Connection. Range: 2.7 to 5.5V |
| 2 | VOUT | Voltage Reference Output. |
| 3 | GND | Ground Connection |

Ordering Information

| PART NUMBER (Notes 1, 2, 3) | PART MARKING (Note 4) | V _{OUT} OPTION (V) | GRADE | TEMP. RANGE (°C) | PACKAGE Tape & Reel (Pb-Free) | PKG. DWG. # |
|---|--------------------------|--------------------------------|------------------|---------------------|-------------------------------------|----------------|
| ISL21070DIH306Z-TK (No longer available, recommended replacement: ISL21070CIH325Z-TK) | BDNA | 0.600 | ±1.0%, 50ppm/°C | -40 to +85 | 3 Ld SOT-23 | P3.064 |
| ISL21070CIH320Z-TK | BCHA | 2.048 | ±0.25%, 30ppm/°C | -40 to +85 | 3 Ld SOT-23 | P3.064 |
| ISL21070CIH325Z-TK | BCJA | 2.5 | ±0.2%, 30ppm/°C | -40 to +85 | 3 Ld SOT-23 | P3.064 |

NOTES:

- Please refer to [TB347](#) for details on reel specifications.
- These Intersil Pb-free plastic packaged products employ special Pb-free material sets, molding compounds/die attach materials, and 100% matte tin plate plus anneal (e3 termination finish, which is RoHS compliant and compatible with both SnPb and Pb-free soldering operations). Intersil Pb-free products are MSL classified at Pb-free peak reflow temperatures that meet or exceed the Pb-free requirements of IPC/JEDEC J STD-020.
- For Moisture Sensitivity Level (MSL), please see device information page for [ISL21070](#). For more information on MSL please see techbrief [TB363](#).
- The part marking is located on the bottom of the part.

Absolute Voltage Ratings

| | |
|---|-------------------------|
| Max Voltage | |
| V_{IN} to GND | -0.5V to +6.5V |
| V_{OUT} (pin) to GND (10s) | -0.5V to $V_{OUT} + 1V$ |
| ESD Ratings | |
| Human Body Model (Tested per JESD22-A114) | 6000V |
| Machine Model (Tested per JESD22-A115) | 500V |
| Charged Device Model (Tested per JESD22-C101) | 2kV |
| Latch Up (Tested Per JESD-78) | 100mA |

Environmental Operating Conditions

| | |
|-------------------------|--------|
| X-Ray Exposure (Note 5) | 10mRem |
|-------------------------|--------|

CAUTION: Do not operate at or near the maximum ratings listed for extended periods of time. Exposure to such conditions may adversely impact product reliability and result in failures not covered by warranty.

NOTES:

- Measured with no filtering, distance of 10" from source, intensity set to 55kV and 70mA current, 30s duration. Other exposure levels should be analyzed for Output Voltage drift effects. See "Applications Information" on page 7.
- θ_{JA} is measured with the component mounted on a high effective thermal conductivity test board in free air. See Tech Brief [TB379](#) for details.
- For θ_{JC} , the "case temp" location is taken at the package top center.
- Post-reflow drift for the ISL21070 devices will range from 100 μ V to 1.0mV based on experimental results with devices on FR4 double sided boards. The design engineer must take this into account when considering the reference voltage after assembly.

Thermal Information

| | | |
|---|---|---------------------------------|
| Thermal Resistance (Typical) | θ_{JA} ($^{\circ}$ C/W) | θ_{JC} ($^{\circ}$ C/W) |
| 3 Ld SOT-23 (Notes 6, 7) | 275 | 110 |
| Continuous Power Dissipation ($T_A = +85^{\circ}$ C) | 99mW | |
| Storage Temperature Range | -65 $^{\circ}$ C to +150 $^{\circ}$ C | |
| Pb-Free Reflow Profile (Note 8) | see link below http://www.intersil.com/pbfree/Pb-FreeReflow.asp | |

Recommended Operating Conditions

| | |
|--------------------------------|--------------------------------------|
| Temperature Range (Industrial) | -40 $^{\circ}$ C to +85 $^{\circ}$ C |
| Supply Voltage | 2.7V to 5.5V |

Electrical Specifications (ISL21070-06, $V_{OUT} = 0.600V$) $V_{IN} = 3.0V$, $T_A = -40^{\circ}$ C to +85 $^{\circ}$ C, $I_{OUT} = 0$, unless otherwise specified. **Boldface limits apply over the operating temperature range, -40 $^{\circ}$ C to +85 $^{\circ}$ C.**

| SYMBOL | PARAMETER | CONDITIONS | MIN (Note 12) | TYP | MAX (Note 12) | UNITS |
|---------------------------------|---|--|------------------|-------|------------------|------------------------|
| V_{OUT} | Output Voltage | | | 0.600 | | V |
| V_{OA} | V_{OUT} Accuracy @ $T_A = +25^{\circ}$ C | ISL21070 D-grade | -1.0 | | +1.0 | % |
| TC V_{OUT} | Output Voltage Temperature Coefficient (Note 9) | ISL21070 D-grade | | | 50 | ppm/ $^{\circ}$ C |
| V_{IN} | Input Voltage Range | | 2.7 | | 5.5 | V |
| I_{IN} | Supply Current | | | 11 | 25 | μ A |
| $\Delta V_{OUT}/\Delta V_{IN}$ | Line Regulation | $2.7V \leq V_{IN} \leq 5.5V$ | | 20 | 250 | μ V/V |
| $\Delta V_{OUT}/\Delta I_{OUT}$ | Load Regulation | Sourcing: $0mA \leq I_{OUT} \leq 10mA$ | | 3 | 100 | μ V/mA |
| | | Sinking: $-10mA \leq I_{OUT} \leq 0mA$ | | 6 | 100 | μ V/mA |
| I_{SC} | Short Circuit Current | $T_A = +25^{\circ}$ C, V_{OUT} tied to GND | | 50 | | mA |
| t_R | Turn-on Settling Time | $V_{OUT} = \pm 0.1\%$ | | 150 | | μ s |
| | Ripple Rejection | $f = 10kHz$ | | -20 | | dB |
| e_N | Output Voltage Noise | $0.1Hz \leq f \leq 10Hz$ | | 30 | | μ V _{P-P} |
| V_N | Broadband Voltage Noise | $10Hz \leq f \leq 10kHz$ | | 10 | | μ V _{RMS} |
| $\Delta V_{OUT}/\Delta T_A$ | Thermal Hysteresis (Note 10) | $\Delta T_A = +125^{\circ}$ C | | 20 | | ppm |
| $\Delta V_{OUT}/\Delta t$ | Long Term Stability (Note 11) | $T_A = +25^{\circ}$ C | | 70 | | ppm |

Electrical Specifications (ISL21070-20, $V_{OUT} = 2.048V$) $V_{IN} = 3.0V$, $T_A = -40^\circ C$ to $+85^\circ C$, $I_{OUT} = 0$, unless otherwise specified. **Boldface limits apply over the operating temperature range, $-40^\circ C$ to $+85^\circ C$**

| SYMBOL | PARAMETER | CONDITIONS | MIN (Note 12) | TYP | MAX (Note 12) | UNIT |
|---------------------------------|---|---|------------------|-------|------------------|-----------------|
| V_{OUT} | Output Voltage | | | 2.048 | | V |
| V_{OA} | V_{OUT} Accuracy @ $T_A = +25^\circ C$ | ISL21070 C-grade: 2.048 | -0.25 | | +0.25 | % |
| TC V_{OUT} | Output Voltage Temperature Coefficient (Note 9) | ISL21070 C-grade | | | 30 | ppm/ $^\circ C$ |
| V_{IN} | Input Voltage Range | | 2.7 | | 5.5 | V |
| I_{IN} | Supply Current | | | 11 | 25 | μA |
| $\Delta V_{OUT}/\Delta V_{IN}$ | Line Regulation | $2.7V \leq V_{IN} \leq 5.5V$ | | 25 | 250 | $\mu V/V$ |
| $\Delta V_{OUT}/\Delta I_{OUT}$ | Load Regulation | Sourcing: $0mA \leq I_{OUT} \leq 10mA$ | | 3 | 100 | $\mu V/mA$ |
| | | Sinking: $-10mA \leq I_{OUT} \leq 0mA$ | | 6 | 100 | $\mu V/mA$ |
| I_{SC} | Short Circuit Current | $T_A = +25^\circ C$, V_{OUT} tied to GND | | 50 | | mA |
| t_R | Turn-on Settling Time | $V_{OUT} = \pm 0.1\%$ | | 150 | | μs |
| | Ripple Rejection | $f = 10kHz$ | | -20 | | dB |
| e_N | Output Voltage Noise | $0.1Hz \leq f \leq 10Hz$ | | 30 | | μV_{P-P} |
| V_N | Broadband Voltage Noise | $10Hz \leq f \leq 10kHz$ | | 10 | | μV_{RMS} |
| $\Delta V_{OUT}/\Delta T_A$ | Thermal Hysteresis (Note 10) | $\Delta T_A = +125^\circ C$ | | 40 | | ppm |
| $\Delta V_{OUT}/\Delta t$ | Long Term Stability (Note 11) | $T_A = +25^\circ C$ | | 50 | | ppm |

Electrical Specifications (ISL21070-25, $V_{OUT} = 2.5V$) $V_{IN} = 3.0V$, $T_A = -40^\circ C$ to $+85^\circ C$, $I_{OUT} = 0$, unless otherwise specified. **Boldface limits apply over the operating temperature range, $-40^\circ C$ to $+85^\circ C$**

| SYMBOL | PARAMETER | CONDITIONS | MIN (Note 12) | TYP | MAX (Note 12) | UNIT |
|---------------------------------|---|---|------------------|-----|------------------|-----------------|
| V_{OUT} | Output Voltage | | | 2.5 | | V |
| V_{OA} | V_{OUT} Accuracy @ $T_A = +25^\circ C$ | ISL21070 C-grade | -0.2 | | +0.2 | % |
| TC V_{OUT} | Output Voltage Temperature Coefficient (Note 9) | ISL21070 C-grade | | | 30 | ppm/ $^\circ C$ |
| V_{IN} | Input Voltage Range | | 2.7 | | 5.5 | V |
| I_{IN} | Supply Current | $V_{EN} = V_{IN}$ | | 11 | 25 | μA |
| $\Delta V_{OUT}/\Delta V_{IN}$ | Line Regulation | $2.7V \leq V_{IN} \leq 5.5V$ | | 15 | 250 | $\mu V/V$ |
| $\Delta V_{OUT}/\Delta I_{OUT}$ | Load Regulation | Sourcing: $0mA \leq I_{OUT} \leq 7mA$ | | 6 | 100 | $\mu V/mA$ |
| | | Sourcing: $0mA \leq I_{OUT} \leq 10mA$ ($T_A = +70^\circ C$) | | 133 | | $\mu V/mA$ |
| | | Sinking: $-10mA \leq I_{OUT} \leq 0mA$ | | 10 | 100 | $\mu V/mA$ |
| I_{SC} | Short Circuit Current | $T_A = +25^\circ C$, V_{OUT} tied to GND | | 30 | | mA |
| t_R | Turn-on Settling Time | $V_{OUT} = \pm 0.1\%$ | | 150 | | μs |
| | Ripple Rejection | $f = 10kHz$ | | -20 | | dB |
| e_N | Output Voltage Noise | $0.1Hz \leq f \leq 10Hz$ | | 30 | | μV_{P-P} |
| V_N | Broadband Voltage Noise | $10Hz \leq f \leq 10kHz$ | | 10 | | μV_{RMS} |
| $\Delta V_{OUT}/\Delta T_A$ | Thermal Hysteresis (Note 10) | $\Delta T_A = +125^\circ C$ | | 20 | | ppm |
| $\Delta V_{OUT}/\Delta t$ | Long Term Stability (Note 11) | $T_A = +25^\circ C$ | | 50 | | ppm |

NOTES:

- Over the specified temperature range. Temperature coefficient is measured by the box method whereby the change in V_{OUT} is divided by the temperature range; in this case, $-40^\circ C$ to $+85^\circ C = +125^\circ C$.
- Thermal Hysteresis is the change of V_{OUT} measured @ $T_A = +25^\circ C$ after temperature cycling over a specified range, ΔT_A . V_{OUT} is read initially at $T_A = +25^\circ C$ for the device under test. The device is temperature cycled and a second V_{OUT} measurement is taken at $+25^\circ C$. The difference between the initial V_{OUT} reading and the second V_{OUT} reading is then expressed in ppm. For $\Delta T_A = +125^\circ C$, the device under test is cycled from $+25^\circ C$ to $+85^\circ C$ to $-40^\circ C$ to $+25^\circ C$.
- Long term drift is logarithmic in nature and diminishes over time. Drift after the first 1000 hours will be approximately $10ppm/\sqrt{1khrs}$
- Compliance to datasheet limits is assured by one or more methods: production test, characterization and/or design.

Typical Performance Characteristics Curves

$V_{OUT} = 2.5V$, $V_{IN} = 3V$, $I_{OUT} = 0mA$, $T_A = +25^\circ C$ unless otherwise specified.

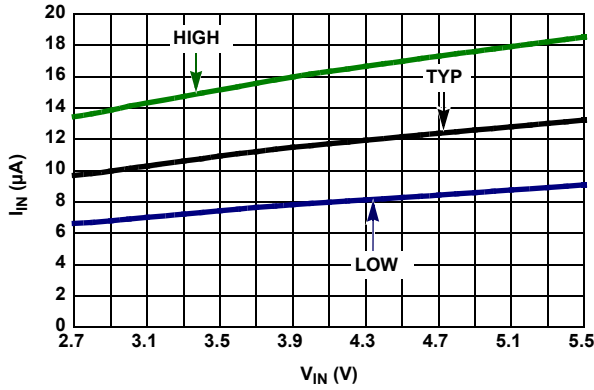

FIGURE 2. I_{IN} vs V_{IN} , 3 UNITS

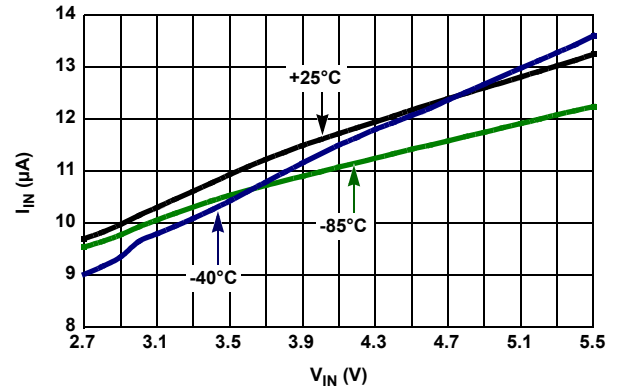

FIGURE 3. I_{IN} vs V_{IN} OVER-TEMPERATURE

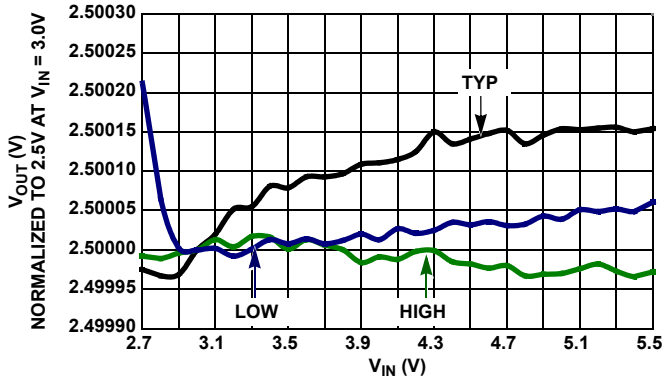

FIGURE 4. LINE REGULATION, 3 UNITS

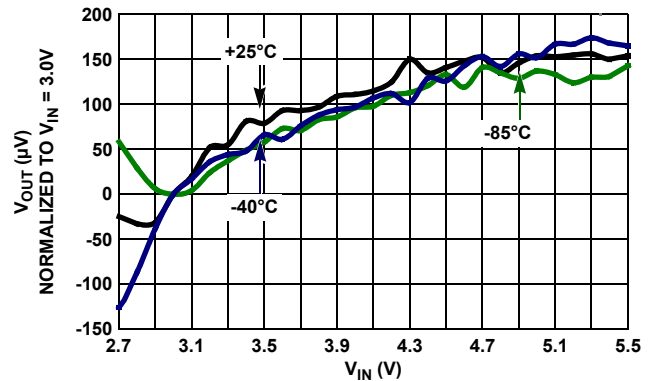

FIGURE 5. LINE REGULATION OVER-TEMPERATURE

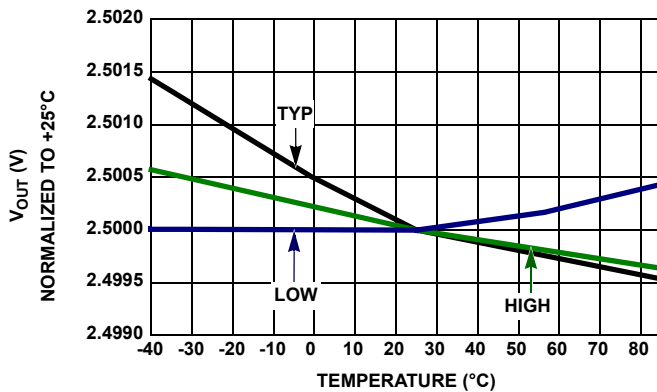

FIGURE 6. V_{OUT} vs TEMPERATURE NORMALIZED TO $+25^\circ C$

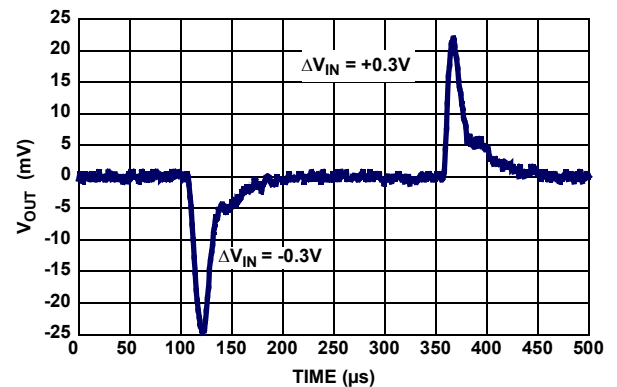

FIGURE 7. LINE TRANSIENT RESPONSE, WITH 1nF CAPACITIVE LOAD

Typical Performance Characteristics Curves

$V_{OUT} = 2.5V$, $V_{IN} = 3V$, $I_{OUT} = 0mA$, $T_A = +25^\circ C$ unless otherwise specified. (Continued)

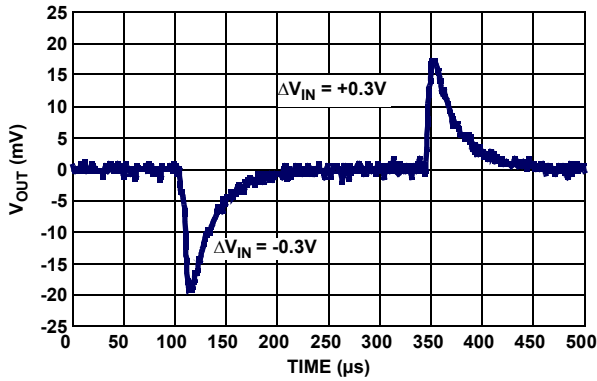

FIGURE 8. LINE TRANSIENT RESPONSE, WITH NO CAPACITIVE LOAD

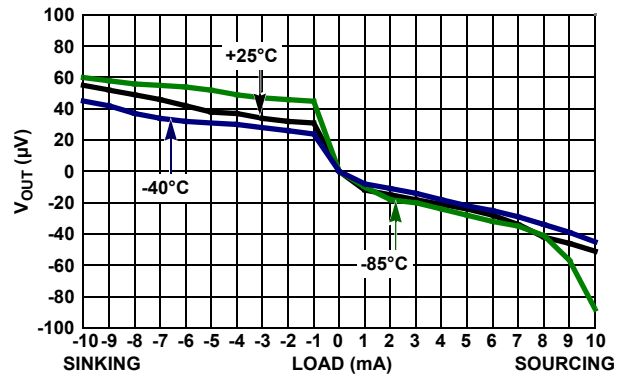

FIGURE 9. LOAD REGULATION OVER-TEMPERATURE

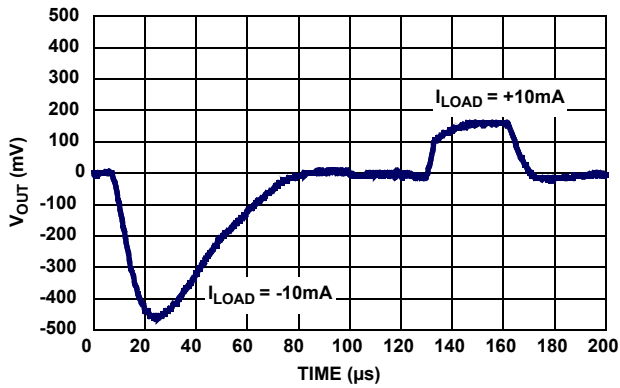

FIGURE 10. LOAD TRANSIENT RESPONSE

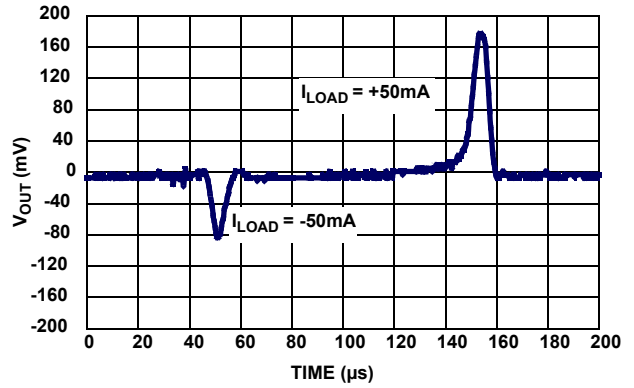

FIGURE 11. LOAD TRANSIENT RESPONSE

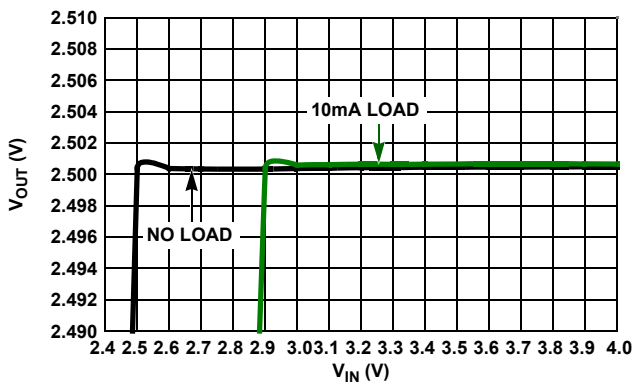

FIGURE 12. DROPOUT

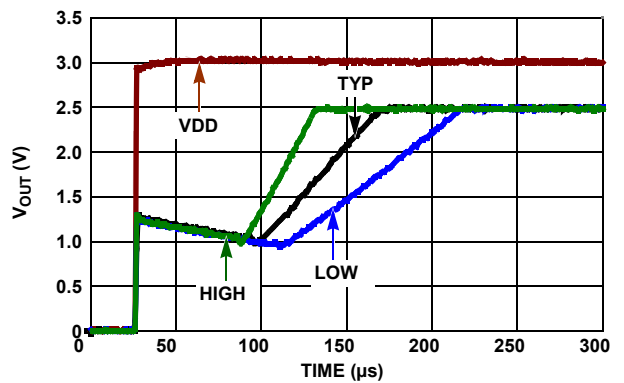

FIGURE 13. TURN-ON TIME

Typical Performance Characteristics Curves

$V_{OUT} = 2.5V$, $V_{IN} = 3V$, $I_{OUT} = 0mA$, $T_A = +25^\circ C$ unless otherwise specified. (Continued)

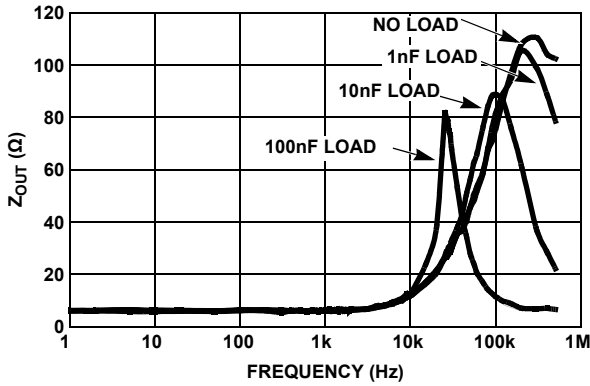

FIGURE 14. Z_{OUT} vs f vs C_L

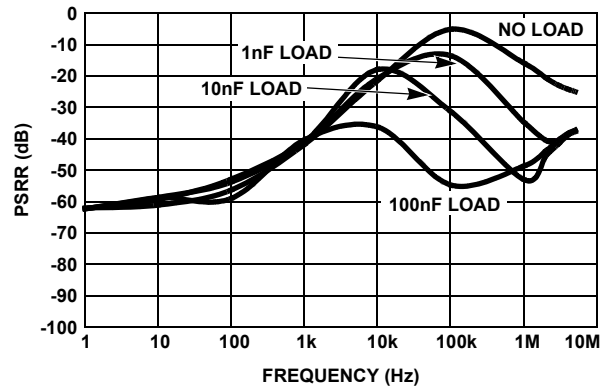

FIGURE 15. PSRR vs FREQUENCY

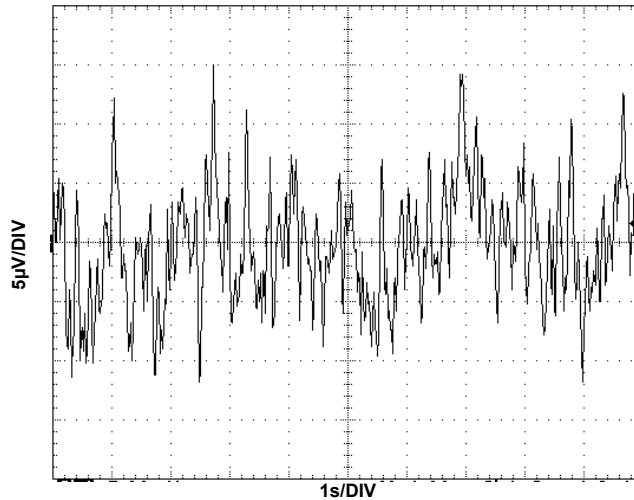

FIGURE 16. V_{OUT} NOISE, 0.1Hz TO 10Hz

Applications Information

FGA Technology

The ISL21070 series of voltage references use the floating gate technology to create references with very low drift and supply current. Essentially, the charge stored on a floating gate cell is set precisely in manufacturing. The reference voltage output itself is a buffered version of the floating gate voltage. The resulting reference device has excellent characteristics which are unique in the industry: very low temperature drift, high initial accuracy, and almost zero supply current. Also, the reference voltage itself is not limited by voltage bandgaps or zener settings, so a wide range of reference voltages can be programmed (standard voltage settings are provided, but customer-specific voltages are available).

The process used for these reference devices is a floating gate CMOS process, and the amplifier circuitry uses CMOS transistors for amplifier and output transistor circuitry. While providing

excellent accuracy, there are limitations in output noise level and load regulation due to the MOS device characteristics. These limitations are addressed with circuit techniques discussed in other sections.

Handling and Board Mounting

FGA references provide excellent initial accuracy and low temperature drift at the expense of very little power drain. There are some precautions to take to insure this accuracy is not compromised. Excessive heat during solder reflow can cause excessive initial accuracy drift, so the recommended $+260^\circ C$ max temperature profile should not be exceeded. Expect up to 1mV drift from the solder reflow process.

FGA references are susceptible to excessive X-radiation like that used in PC board manufacturing. Initial accuracy can change 10mV or more under extreme radiation. If an assembled board needs to be X-rayed, care should be taken to shield the FGA reference device.

Board Mounting Considerations

For applications requiring the highest accuracy, board mounting location should be reviewed. Placing the device in areas subject to slight twisting can cause degradation of the accuracy of the reference voltage due to die stresses. It is normally best to place the device near the edge of a board, or the shortest side, as the axis of bending is most limited at that location. Obviously, mounting the device on flexprint or extremely thin PC material will likewise cause loss of reference accuracy.

Board Assembly Considerations

FGA references provide high accuracy and low temperature drift but some PC board assembly precautions are necessary. Normal Output voltage shifts of 100 μ V to 1mV can be expected with Pb-free reflow profiles or wave solder on multi-layer FR4 PC boards. Precautions should be taken to avoid excessive heat or extended exposure to high reflow or wave solder temperatures, this may reduce device initial accuracy.

Post-assembly x-ray inspection may also lead to permanent changes in device output voltage and should be minimized or avoided. If x-ray inspection is required, it is advisable to monitor the reference output voltage to verify excessive shift has not occurred. If large amounts of shift are observed, it is best to add an X-ray shield consisting of thin zinc (300 μ m) sheeting to allow clear imaging, yet block x-ray energy that affects the FGA reference.

Special Applications Considerations

In addition to post-assembly examination, there are also other X-ray sources that may affect the FGA reference long term accuracy. Airport screening machines contain X-rays and will have a cumulative effect on the voltage reference output accuracy. Carry-on luggage screening uses low level X-rays and is not a major source of output voltage shift, however, if a product is expected to pass through that type of screening over 100 times, it may need to consider shielding with copper or aluminum. Checked luggage X-rays are higher intensity and can cause output voltage shift in much fewer passes, thus devices expected to go through those machines should definitely consider shielding. Note that just two layers of 1/2 ounce copper planes will reduce the received dose by over 90%. The leadframe for the device which is on the bottom also provides similar shielding.

If a device is expected to pass through luggage X-ray machines numerous times, it is advised to mount a 2-layer (minimum) PC board on the top, and along with a ground plane underneath will effectively shield it from 50 to 100 passes through the machine. Since these machines vary in X-ray dose delivered, it is difficult to produce an accurate maximum pass recommendation.

Noise Performance and Reduction

The output noise voltage in a 0.1Hz to 10Hz bandwidth is typically 30 μ V_{p.p.} The noise measurement is made with a bandpass filter made of a 1 pole high-pass filter with a corner frequency at 0.1Hz and a 2-pole low-pass filter with a corner frequency at 12.6Hz to create a filter with a 9.9Hz bandwidth. Wideband noise is reduced by adding capacitor to the output, but the value should be limited to 1nF or less to insure stability.

Temperature Drift

The limits stated for output accuracy over-temperature are governed by the method of measurement. For the -40 °C to 85 °C temperature range, measurements are made at +25 °C and the two extremes. This measurement method combined with the fact that FGA references have a fairly linear temperature drift characteristic insures that the limits stated will not be exceeded over the temperature range.

ISL21070 Used as a Low Cost Precision Current Source

Using an N-JET and the ISL21070, a precision, low cost, high impedance current source can be created. The precision of the current source is largely dependent on the tempco and accuracy of the reference. The current setting resistor contributes less than 20% of the error.

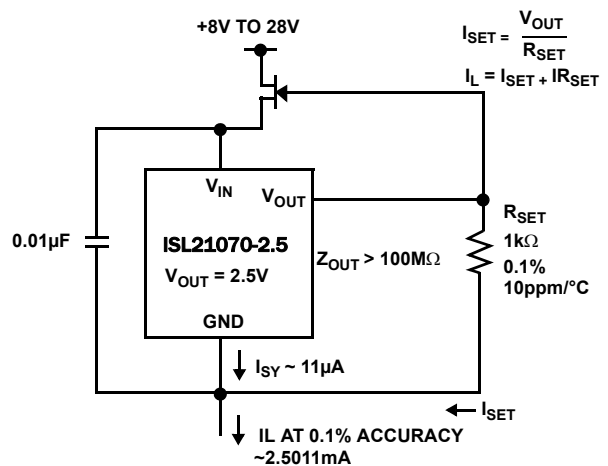

FIGURE 17. ISL21070 USED AS A LOW COST PRECISION CURRENT SOURCE

Typical Application Circuits

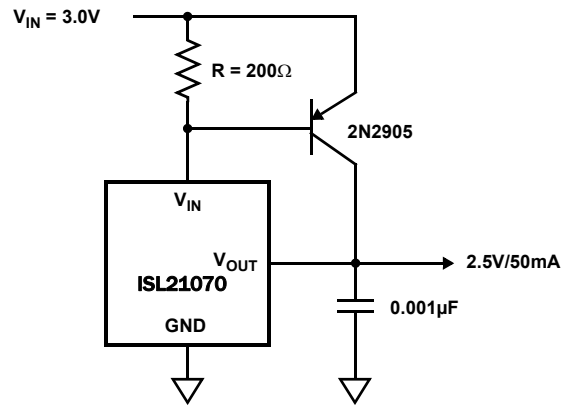

FIGURE 18. PRECISION 2.5V 50mA REFERENCE

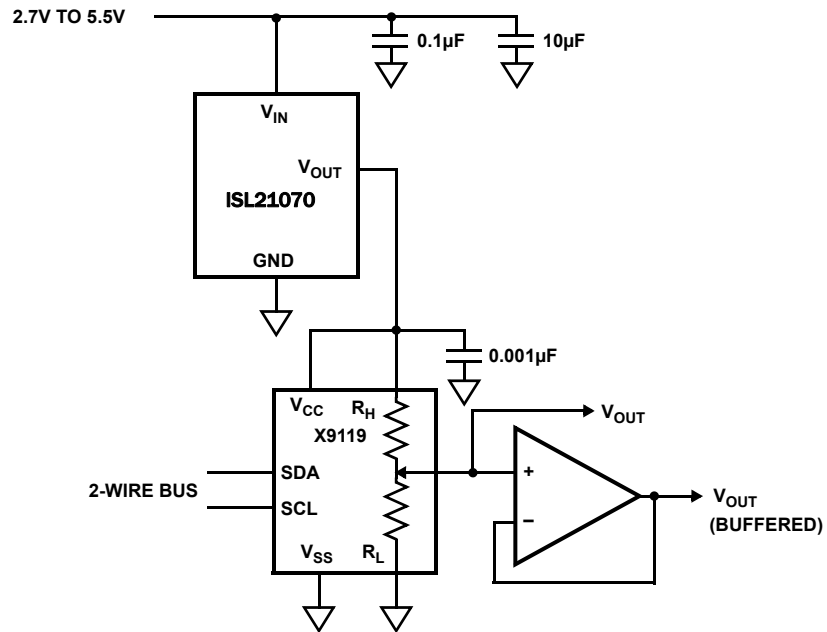

FIGURE 19. 2.5V FULL SCALE LOW-DRIFT 10-BIT ADJUSTABLE VOLTAGE SOURCE

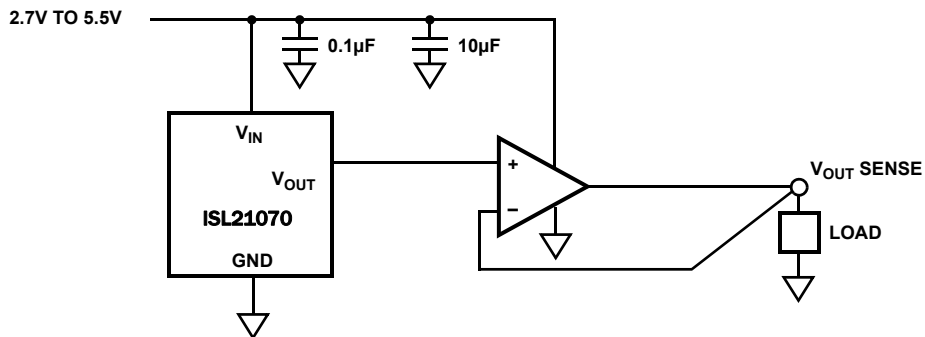

FIGURE 20. KELVIN SENSED LOAD

Revision History

The revision history provided is for informational purposes only and is believed to be accurate, but not warranted. Please go to web to make sure you have the latest Rev.

| DATE | REVISION | CHANGE |
|-------------------|----------|--|
| September 3, 2015 | FN7599.4 | Updated Ordering Information Table on page 2. |
| June 23, 2014 | FN7599.3 | <ul style="list-style-type: none"> • Updated POD with following changes: In Detail A, changed lead width dimension from 0.13+/-0.05 to 0.085-0.19 Changed dimension of foot of lead from 0.31+/-0.10 to 0.38+/-0.10 In Land Pattern, added 0.4 Rad Typ dimension In Side View, changed height of package from 0.91+/-0.03 to 0.95+/-0.07 |
| April 4, 2011 | FN7599.2 | <p>Converted to New Intersil Template</p> <p>Updated page 1 description (removed 3.3V from last paragraph)</p> <p>Updated "Features" on page 1 as follows:</p> <ul style="list-style-type: none"> -Removed 3.3V from Reference Output Voltage bullet. -Removed "Initial Accuracy: 3.3V from 2.5V...±0.2% option" -Removed "ISL21070-33 (Coming Soon)" under Input Voltage Range bullet <p>Updated "Ordering Information" on page 2 as follows:</p> <ul style="list-style-type: none"> -Removed ISL21070CIH333Z-TK 3.3V option <p>Updated "Electrical Specification" as follows:</p> <ul style="list-style-type: none"> -Removed 3.3V option electrical specification header and table <p>Updated Parameters Note in Electrical spec from "parameters..." to "compliance..."</p> |
| April 19, 2010 | FN7599.1 | <p>Added product variation for 0.6V and 2.048V. Removed 1.024V coming soon part. Updated throughout accordingly as follows:</p> <p>Updated page 1 description (removed 1.024V from last paragraph and added 0.6V)</p> <p>Updated "Features" on page 1 as follows:</p> <ul style="list-style-type: none"> -removed 1.024V from Reference Output Voltage bullet. Added 0.600V. -removed "Initial Accuracy: 1.024V . . . ±0.5%" and added "Initial Accuracy: 0.600V . . . ±1.0%" -removed "Coming Soon" from ISL21070-20 under Input Voltage Range bullet. Also, removed ISL21070-10 (coming soon) part and added ISL21070-06 part. -added "Tempco (0.600V only). . . . 50ppm/°C" -added "all others" to "Tempco (all others) . . . 30ppm/°C" <p>Updated "Ordering Information" on page 2 to add ISL21070DIH306Z-TK 0.6V option. Removed 1.024V option ISL21070CIH310Z-TK</p> <p>Added Note 4 to Part Marking column of "Ordering Information" on page 2.</p> <ul style="list-style-type: none"> -Added "Electrical Specifications (ISL21070-06, VOUT = 0.600V)" table to page 3 and "Electrical Specifications (ISL21070-20, VOUT = 2.048V)" table to page 4 -Removed "Electrical Specifications (ISL21070-xx, VOUT = 1.024V to 2.048V)" table <p>Added Theta JC of 110 to "Thermal Information" on page 3. Added applicable Theta JC Note 7 ("For θ_{JC}, the "case temp" location is taken at the package top center.")</p> <p>Revised Theta JA in "Thermal Information" on page 3 from 371 to 275</p> <p>Added Figure 16. "VOUT NOISE, 0.1Hz TO 10Hz" to page 7.</p> |
| March 19, 2010 | FN7599.0 | Initial release. |

About Intersil

Intersil Corporation is a leading provider of innovative power management and precision analog solutions. The company's products address some of the largest markets within the industrial and infrastructure, mobile computing and high-end consumer markets.

For the most updated datasheet, application notes, related documentation and related parts, please see the respective product information page found at www.intersil.com.

You may report errors or suggestions for improving this datasheet by visiting www.intersil.com/ask.

Reliability reports are also available from our website at www.intersil.com/support

© Copyright Intersil Americas LLC 2010-2015. All Rights Reserved.
All trademarks and registered trademarks are the property of their respective owners.

For additional products, see www.intersil.com/en/products.html

Intersil products are manufactured, assembled and tested utilizing ISO9001 quality systems as noted in the quality certifications found at www.intersil.com/en/support/qualandreliability.html

Intersil products are sold by description only. Intersil may modify the circuit design and/or specifications of products at any time without notice, provided that such modification does not, in Intersil's sole judgment, affect the form, fit or function of the product. Accordingly, the reader is cautioned to verify that datasheets are current before placing orders. Information furnished by Intersil is believed to be accurate and reliable. However, no responsibility is assumed by Intersil or its subsidiaries for its use; nor for any infringements of patents or other rights of third parties which may result from its use. No license is granted by implication or otherwise under any patent or patent rights of Intersil or its subsidiaries.

For information regarding Intersil Corporation and its products, see www.intersil.com

Package Outline Drawing

P3.064

3 LEAD SMALL OUTLINE TRANSISTOR PLASTIC PACKAGE (SOT23-3)

Rev 3, 3/12

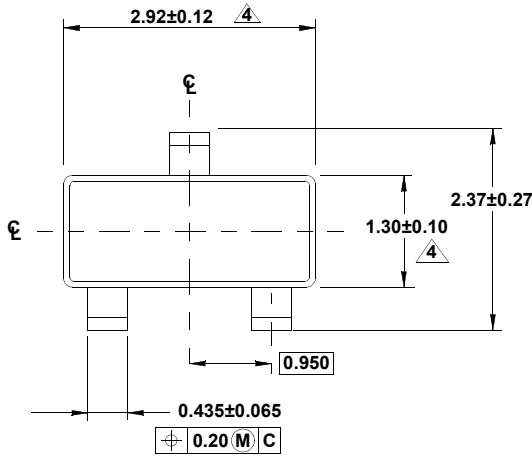

TOP VIEW

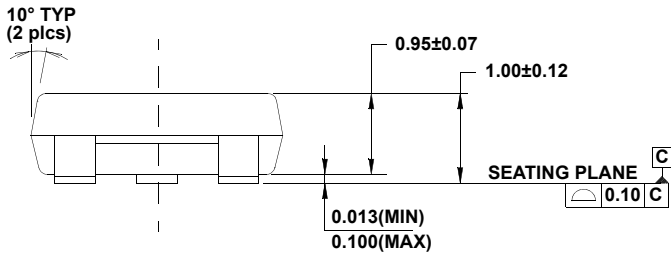
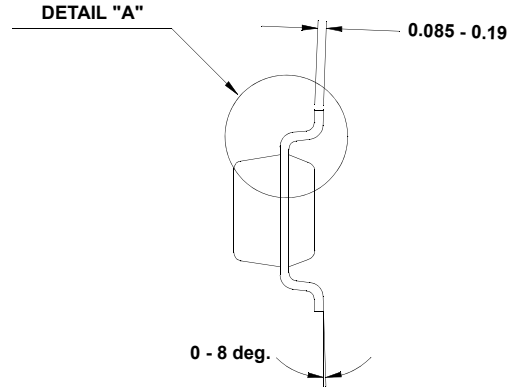

SIDE VIEW

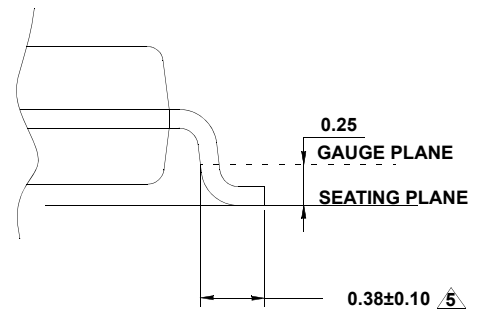

DETAIL "A"

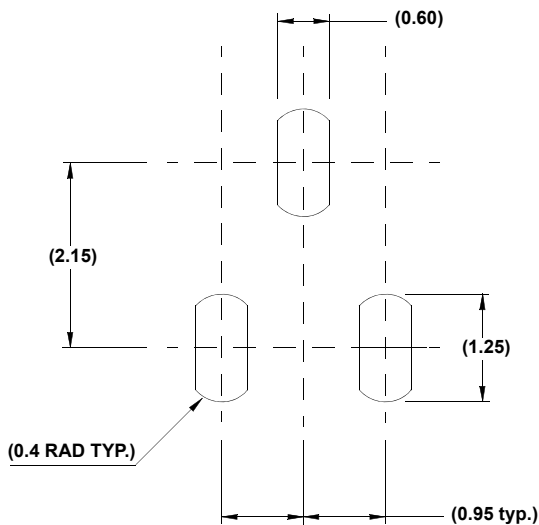

TYPICAL RECOMMENDED LAND PATTERN

NOTES:

1. Dimensions are in millimeters. Dimensions in () for Reference Only.
2. Dimensioning and tolerancing conform to AMSEY14.5m-1994.
3. Reference JEDEC TO-236.
4. Dimension does not include interlead flash or protrusions. Interlead flash or protrusions shall not exceed 0.25mm per side.
5. Footlength is measured at reference to gauge plane.