

In case of consideration for using Automotive equipment / device which demand high reliability, kindly contact our sales window correspondents.

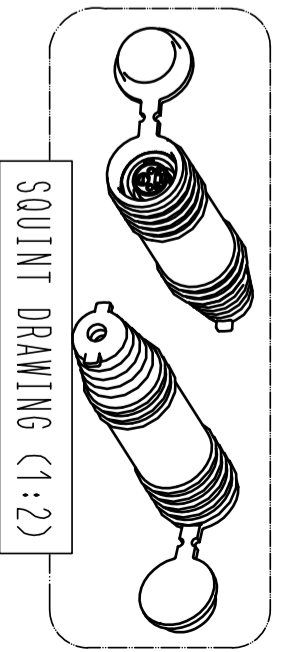
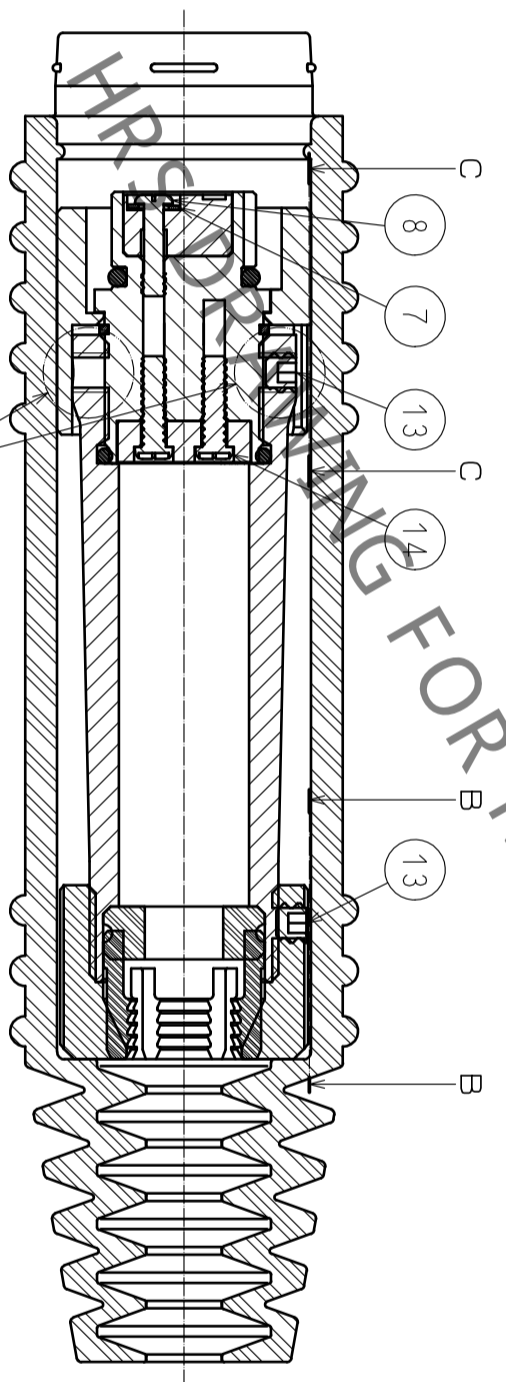
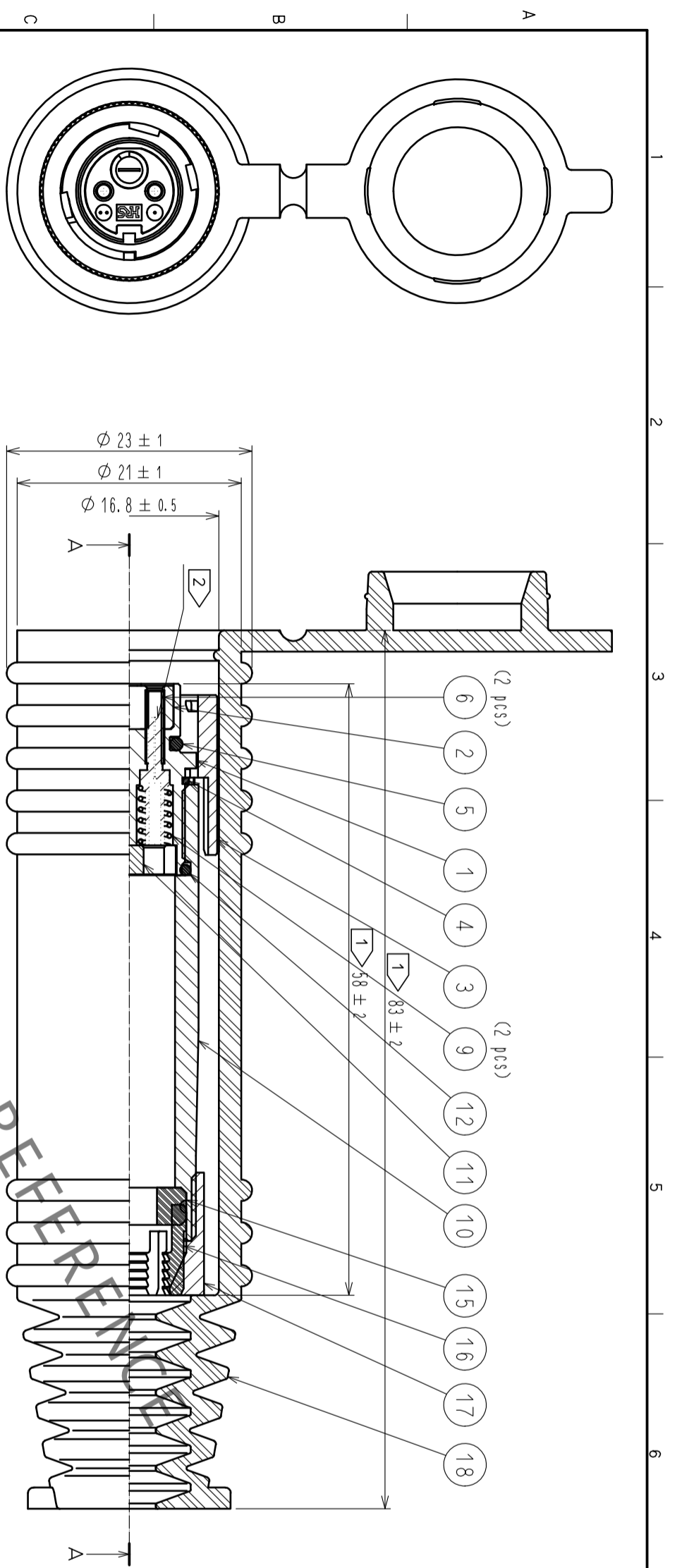

NOTE

- 1 These dimensions indicate the condition after cable assembly.
- 2 Ferrules are not included in this product. MU ferrules are separately available.
- 3 For connector mating, slide back rubber hood of part No. 18 until whole sleeve of part No. 3 is appeared. After mating, slide the rubber hood back until it touches to the receptacle.
- 4 Housing of part No. 10 has two holes for fixing with sleeve of part No. 1 by hexagon socket screw of part No. 13. Tighten the screw at either hole that is visible from a slit on the sleeve as shown in cross section C-C.
- 5 Tightening ring of part No. 17 has two holes for fixing hexagon socket screw of part No. 13. Tighten the screw at visible either hole, or either hole if both holes are visible.
- 6 For cleaning of the ferrule end, loosen the screw of part No. 8 and pick up the pre-assembled P shell B of part No. 2 by pulling the screw of part No. 8. Then, remove the split sleeves by using separately available sleeve-remover and clean the ferrules.

NO.	MATERIAL	FINISH	REMARKS	NO.	MATERIAL	FINISH	REMARKS
9	PIANO WIRE			18	SYNTHETIC RUBBER		
8	STAINLESS STEEL			17	ZINC DIE CASTING	CHROME PLATING	
7	STAINLESS STEEL			16	SYNTHETIC RESIN		
6	ZIRCONIA			15	SYNTHETIC RUBBER		
5	SYNTHETIC RUBBER			14	STAINLESS STEEL		
4	STAINLESS STEEL			13	STAINLESS STEEL		
3	ZINC DIE CASTING	CHROME PLATING		12	SYNTHETIC RUBBER		
2	ZINC DIE CASTING	CHROME PLATING		11	ZINC DIE CASTING	NICKEL PLATING	
1	ZINC DIE CASTING	CHROME PLATING		10	ZINC DIE CASTING	CHROME PLATING	

UNITS	SCALE	COUNT	DESCRIPTION OF REVISIONS	DESIGNED	CHECKED	DATE
mm	2 : 1					

APPROVED	CHECKED	DESIGNED	DRAWING	PART NO.	CODE
MT. SHIBUTANI	MT. SHIBUTANI	SI. MATSUMOTO	EDC-177234-31-00	MF10B-WP5CH01-0200(31)	CL709-1015-8-31
18.03.28	18.03.28	18.03.28			
HIROSE ELECTRIC CO., LTD.					