

Fig. 1

### 1. INTRODUCTION

This instruction sheet (IS) covers the AMP Extraction/Lance Reset Tool used to remove contacts from AMPMODU Level V connectors, and to reset overly depressed contact locking lances. See Figure 1.

### 2. DESCRIPTION (Figure 1)

Each tool includes a lance-release tip and tool stop on one end, and a beveled reset tip on the other end. The part number for the tool is centrally marked. The lance-release tip depresses the contact locking lance to permit contact extraction, and the tool stop prevents over-insertion of the tip. The reset tip repositions the depressed locking lance to its proper height — assuring engagement of the contact with the window shoulder, and contact retention in the housing cavity.

NOTE

*All dimensions presented on this sheet are in inches.*

### 3. EXTRACTION PROCEDURE (Figure 2)

Notice the edge of the locking lance visible at each cavity window, before proceeding with the following steps:

1. Align lance-release tip parallel with the long side of the window, and orient the 45° tip taper toward the locking lance.

2. Insert tool tip between locking lance and housing window until the tool stop bottoms.
3. Pull back lightly on the terminated wire and, if necessary, move tool just enough to release the contact lance.
4. Remove the contact from the housing, and remove the tool.

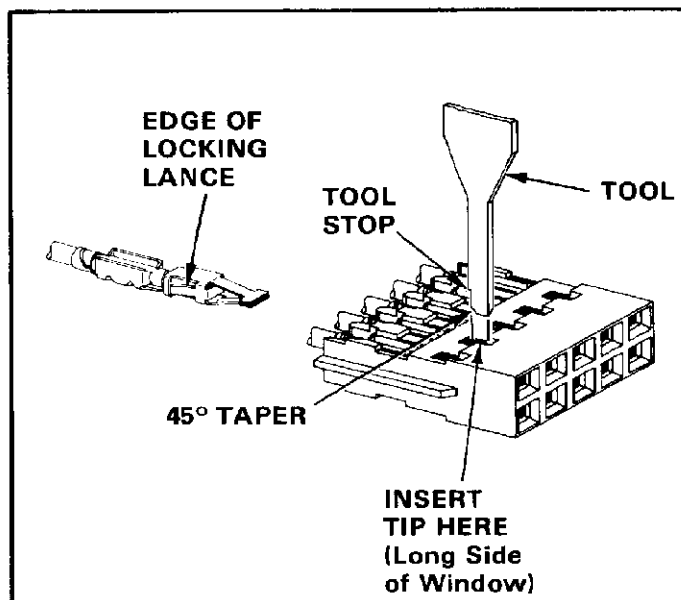

Fig. 2

Copyright 1983 by AMP Incorporated, Harrisburg, PA. All International Rights Reserved. AMP Incorporated products covered by U.S. and Foreign patents and/or patents pending.

AMP EXTRACTION/LANCE RESET TOOL 91409

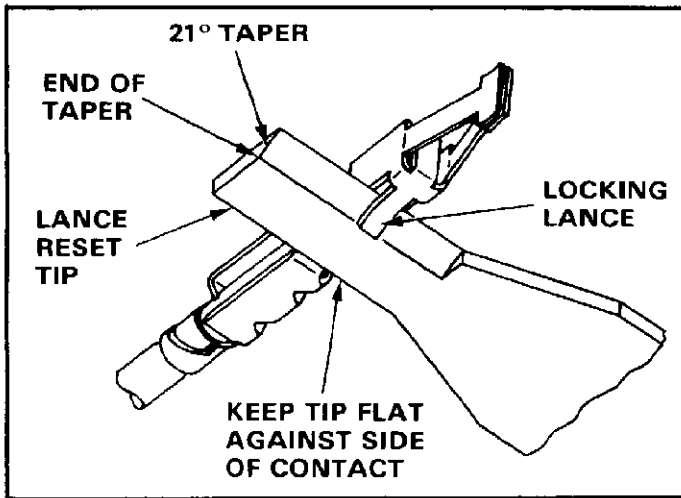

Fig. 3

4. LOCKING LANCE RESET PROCEDURE (Figure 3)

This procedure is designed to reposition depressed locking lances to ensure contact retention in the housing cavity.

1. Orient the reset tip so that the beveled edge faces the locking lance.
2. Keep the reset tip flat against the side of the contact (behind the lance). Slide the beveled edge toward the base of the lance until the leading edge of the lance meets the end of the 21° taper.
3. Remove tool tip, and check contact before re-inserting it into housing cavity.

5. TOOL CERTIFICATION (Figure 4)

The tool listed on this instruction sheet should be certified with the information provided in Figure 4. The tool should be inspected immediately upon arrival at your facility to be sure it has not been damaged in transit, and at regularly scheduled intervals to be sure it remains functional.

Additional tools can be purchased from:

AMP Incorporated  
 Eisenhower Boulevard  
 Harrisburg, Pennsylvania 17105

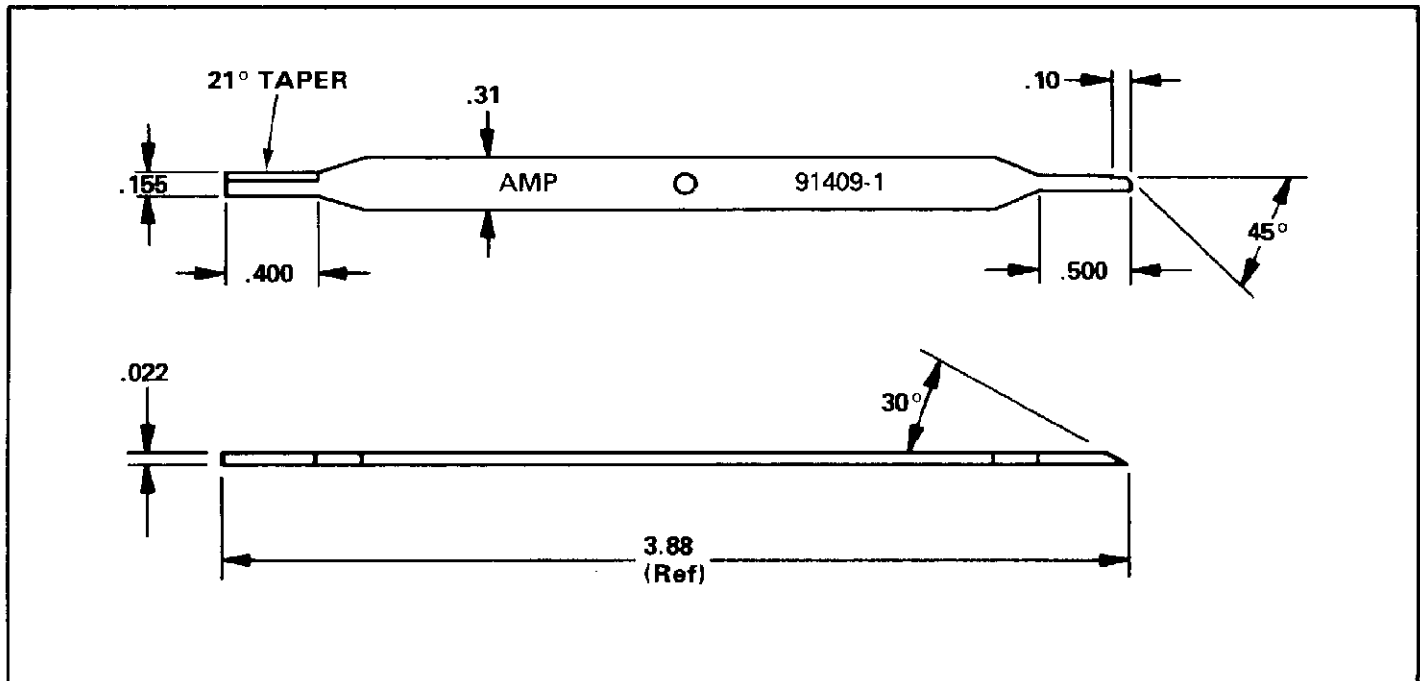

TOOL SPECIFICATIONS		ENGINEERING APPROVAL	DATE
PART NO.	WEIGHT		
91409-1	2 oz	<i>J.T. Casey</i>	10-19-83

Fig. 4