

NOTE:
1. ALL SIGNAL GROUNDS ARE BUSSED IN PCB.

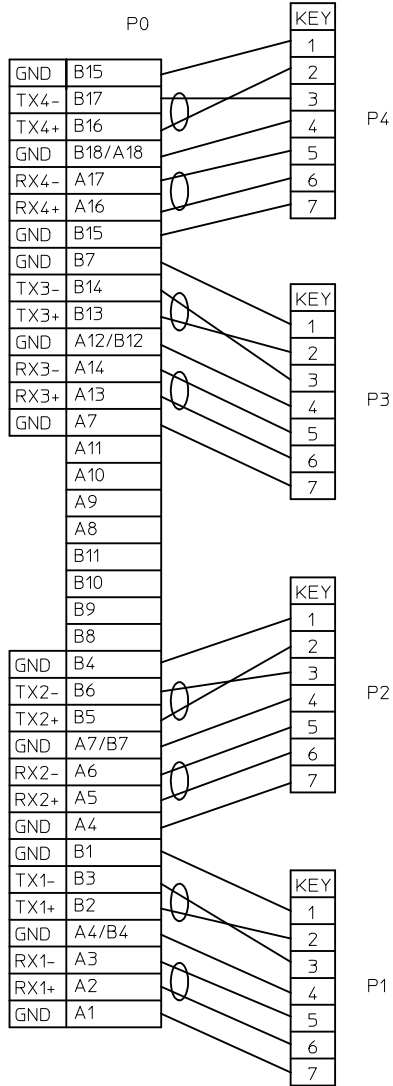

IPASS™ IS A TRADEMARK OF MOLEX.

| ITEM | DESCRIPTION | L (mm) | QTY. |
|------|--|---------|------|
| K | Braid sleeving | 670REF | 1 |
| J | 2x28AWG-S;SHLD:PVC;RD:1.70x6.50MM;S-ATA -40C~85C | 4610REF | |
| I | BLACK PVC | A/R | |
| H | BLCK TAPE | A/R | 2 |
| G | LABEL | | 4 |
| F | HST F 12MM 125C (UL) BLK | A/R | 2 |
| E | SINGLE ATA CONN. | | 4 |
| D | 36CKT PCB | | 1 |
| C | PE MATERIAL | A/R | |
| B | PBT | A/R | |
| A | LATCH | | 1 |

| | | | | | | | | | | | |
|---|-------------------------------|---|---------|----------------------------|--------------------|---|-------------------------------|------------------------|--|--|--|
| ENTER DESCRIPTION EC NO: USY2011-0505 DRWN: ZYYU 2011/01/14 CHKD: ARES FENG 2011/01/14 APPR: CLAN01 2011/01/14 REV B | QUALITY SYMBOLS ▽=0 ▽=0 | GENERAL TOLERANCES (UNLESS SPECIFIED) | | DIMENSION STYLE MM ONLY | | SCALE --- | DESIGN UNITS METRIC | THIRD ANGLE PROJECTION | | | |
| | | 4 PLACES ± --- ± --- 3 PLACES ± --- ± --- 2 PLACES ± 0.13 ± --- 1 PLACE ± 0.25 ± --- | mm INCH | DRAWN BY ZYYU | DATE 2010/12/10 | TITLE 36CKTIPASS STR-(4)SATA,SAS 2.0 | | MOLEX INCORPORATED | | | |
| | | ANGULAR ±1/2° | | CHECKED BY ARES FENG | DATE 2010/12/10 | MATERIAL NO. 1110961051 | DOCUMENT NO. SD-111096-008 | | | | |
| | | DRAFT WHERE APPLICABLE MUST REMAIN WITHIN DIMENSIONS | | | | THIS DRAWING CONTAINS INFORMATION THAT IS PROPRIETARY TO MOLEX INCORPORATED AND SHOULD NOT BE USED WITHOUT WRITTEN PERMISSION | | | | | |