

THIS DRAWING IS UNPUBLISHED. RELEASED FOR PUBLICATION  
 © COPYRIGHT - By - ALL RIGHTS RESERVED.

REVISIONS					
P	LTR	DESCRIPTION	DATE	DWN	APVD
AV		REVISED PER ECO-12-012316	05JUL12	KH	MZ
AW		REVISED PER ECO-17-009977	12JUL2017	RS	MZ

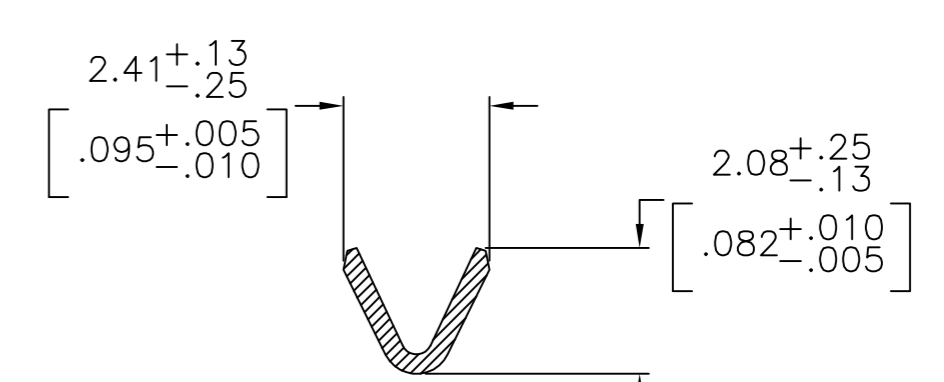
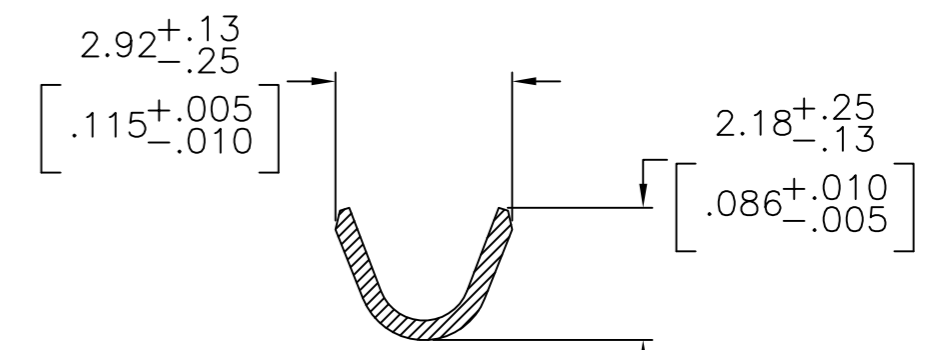
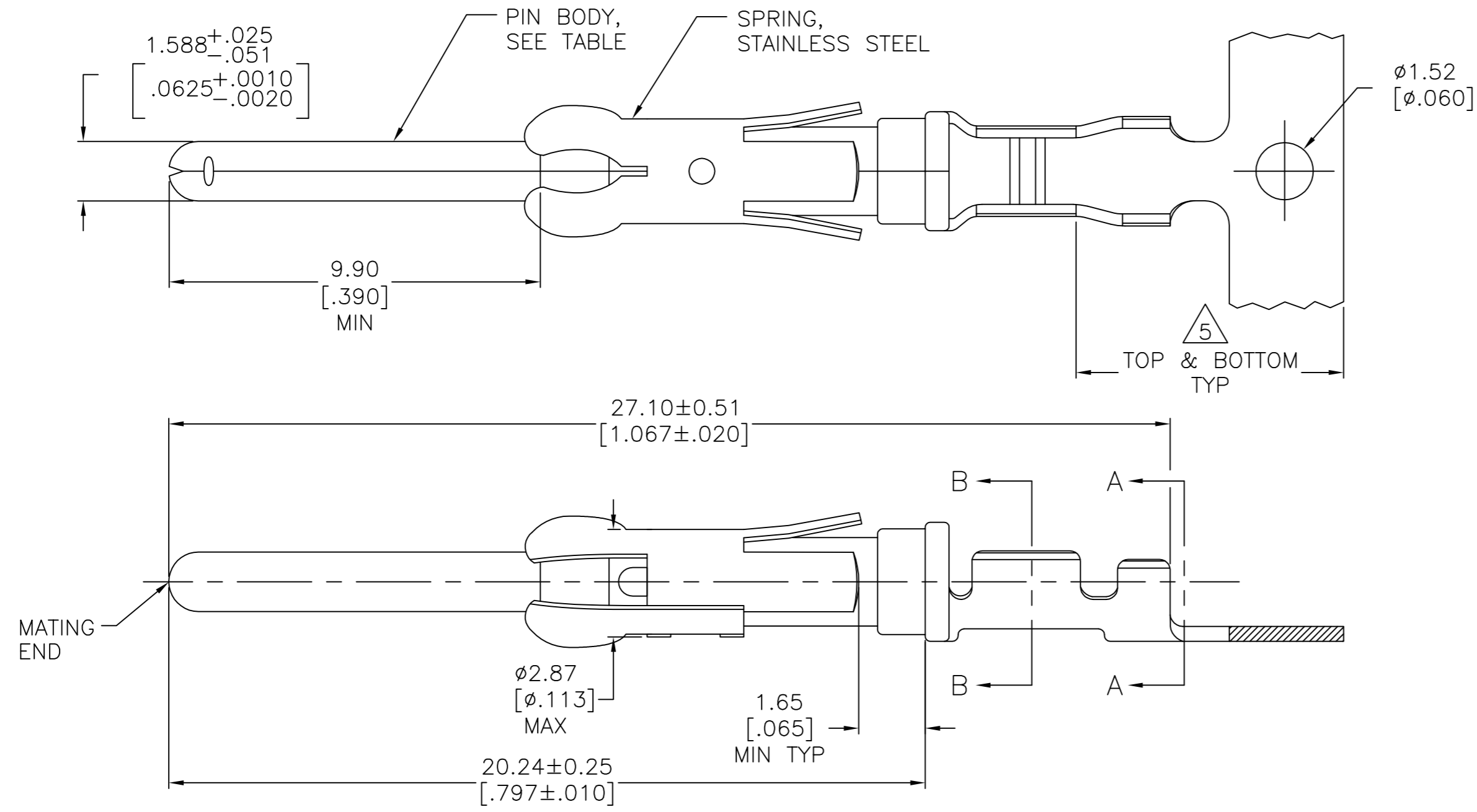

- 1 REVERSE REELED FOR MINI-APPLICATOR.
- 2 0.76 $\mu$ m [.000030] MIN PRECIOUS METAL PLATE ON MATING END FOR A LENGTH OF 5.08 [.200] MIN WITH 1.27 $\mu$ m [.000050] MIN MATTE TIN PLATE IN WIRE CRIMP AREA, BOTH OVER 1.27 $\mu$ m [.000050] MIN NICKEL PLATE. CONFORMS TO THE REQUIREMENTS OF TE CONNECTIVITY PRODUCT SPEC 108-10042, BASED ON EIA/ECA-364-1000.01 ( CONTROLLED ENVIRONMENT APPLICATIONS ),
- 3 0.76 $\mu$ m [.000030] MIN PRECIOUS METAL PLATE ON MATING END FOR A LENGTH OF 5.08 [.200] MIN WITH A UNIFORM GRADIENT TO 0.25 $\mu$ m [.000010] MIN ON REMAINDER, OVER 1.27 $\mu$ m [.000050] MIN NICKEL PLATE. GOLD FLASH ALL OVER. CONFORMS TO THE REQUIREMENTS OF TE CONNECTIVITY PRODUCT SPEC 108-10042, BASED ON EIA/ECA-364-1000.01 ( CONTROLLED ENVIRONMENT APPLICATIONS ).
- 4 0.38 $\mu$ m [.000015] MIN GOLD PER MIL-G-45204 ON MATING END FOR A LENGTH OF 5.08 [.200] MIN WITH 1.27 $\mu$ m [.000050] MIN MATTE TIN PLATE IN WIRE CRIMP AREA, BOTH OVER 1.27 $\mu$ m [.000050] MIN NICKEL PER QQ-N-290.
- 5 GOLD PLATING NEED NOT APPEAR IN THIS AREA.
- 6 1.27 $\mu$ m [.000050] MIN GOLD PER MIL-G-45204 ON MATING END FOR A LENGTH OF 5.08 [.200] MIN WITH GOLD FLASH ON THE REMAINDER OVER 1.90 $\mu$ m [.000075] MIN NICKEL PER QQ-N-290.
- 7 1.27 $\mu$ m [.000050] MIN TIN-LEAD PER MIL-T-10727 OVER 1.27 $\mu$ m [.000050] MIN NICKEL PER QQ-N-290.
- 8 WIRE RANGE 24-20 AWG.
- 9 INSULATION RANGE 1.02[.040]-2.03[.080] DIA.
- 10 0.38 $\mu$ m [.000015] MIN GOLD PER MIL-G-45204 ON MATING END FOR A LENGTH OF 5.08 [.200] MIN, 1.27 $\mu$ m [.000050] MIN TIN-LEAD PER MIL-T-10727 FOR A LENGTH OF 5.69 [.224] MIN ON OPPOSITE END, BOTH OVER 1.27 $\mu$ m [.000050] MIN NICKEL PER QQ-N-290 ON ENTIRE CONTACT.
- 11 1.27 $\mu$ m [.000050] MIN TIN PER MIL-T-10727 OVER 1.27 $\mu$ m [.000050] MIN NICKEL PER QQ-N-290.
- 12 0.38 $\mu$ m [.000015] MIN GOLD PER MIL-G-45204 ON MATING END FOR A LENGTH OF 5.08 [.200] MIN, 1.27 $\mu$ m [.000050] MIN TIN FOR A LENGTH OF 5.69 [.224] MIN ON OPPOSITE END, BOTH OVER 1.27 $\mu$ m [.000050] MIN NICKEL PER QQ-N-290 ON ENTIRE CONTACT.
- 13 2.54 $\mu$ m [.000100] MIN SILVER OVER 0.76 $\mu$ m [.000030] MIN NICKEL PER QQ-N-290
- 14 OBSOLETE PARTS: OBSOLETE CIS STREAMLINING PER D.RENAUD/D.SINISI

14	OBSOLETE	1	13	BRASS	-	2-66102-8
14	OBSOLETE	1	12	BRASS	-	2-66102-7
	STANDARD	1	11	BRASS	1-66103-8	2-66102-6
		1	11	BRASS	1-66103-8	2-66102-5
14	OBSOLETE	1	10	BRASS	1-66103-3	2-66102-3
	OBSOLETE	1	2	PHOSPHOR BRONZE	1-66103-2	2-66102-2
	OBSOLETE	1	7	PHOSPHOR BRONZE	1-66103-1	2-66102-1
	OBSOLETE	1	6	BRASS	1-66103-0	1-66102-7
		1	2	BRASS	66103-4	66102-9
		1	4	BRASS	66103-3	66102-8
		1	7	BRASS	66103-2	66102-7
		1	3	BRASS	66103-1	66102-6
	STANDARD		2	BRASS	66103-4	66102-4
	STANDARD		4	BRASS	66103-3	66102-3
	STANDARD		7	BRASS	66103-2	66102-2
	STANDARD		3	BRASS	66103-1	66102-1
	REELING			PIN BODY FINISH		
				PIN BODY		LOOSE PIECE REF
						PART NO

THIS DRAWING IS A CONTROLLED DOCUMENT.

DWN V. FURLER 11JUL03		NAME	PIN ASSEMBLY, .062, TYPE III+
CHK G. STEINHAEUER 11JUL03		SIZE	
APVD G. STEINHAEUER 11JUL03		CAGE CODE	
PRODUCT SPEC		DRAWING NO	
APPLICATION SPEC	RESTRICTED TO		
WEIGHT	A2	00779	C=66102
CUSTOMER DRAWING	SCALE	8:1	SHEET 1 of 1