

VSC8514 Datasheet
Quad-Port 10/100/1000BASE-T PHY with Synchronous
Ethernet and QSGMII MAC



a  **MICROCHIP** company



Microsemi Headquarters

One Enterprise, Aliso Viejo,
CA 92656 USA

Within the USA: +1 (800) 713-4113

Outside the USA: +1 (949) 380-6100

Sales: +1 (949) 380-6136

Fax: +1 (949) 215-4996

Email: sales.support@microsemi.com

www.microsemi.com

©2018 Microsemi, a wholly owned subsidiary of Microchip Technology Inc. All rights reserved. Microsemi and the Microsemi logo are registered trademarks of Microsemi Corporation. All other trademarks and service marks are the property of their respective owners.

Microsemi makes no warranty, representation, or guarantee regarding the information contained herein or the suitability of its products and services for any particular purpose, nor does Microsemi assume any liability whatsoever arising out of the application or use of any product or circuit. The products sold hereunder and any other products sold by Microsemi have been subject to limited testing and should not be used in conjunction with mission-critical equipment or applications. Any performance specifications are believed to be reliable but are not verified, and Buyer must conduct and complete all performance and other testing of the products, alone and together with, or installed in, any end-products. Buyer shall not rely on any data and performance specifications or parameters provided by Microsemi. It is the Buyer's responsibility to independently determine suitability of any products and to test and verify the same. The information provided by Microsemi hereunder is provided "as is, where is" and with all faults, and the entire risk associated with such information is entirely with the Buyer. Microsemi does not grant, explicitly or implicitly, to any party any patent rights, licenses, or any other IP rights, whether with regard to such information itself or anything described by such information. Information provided in this document is proprietary to Microsemi, and Microsemi reserves the right to make any changes to the information in this document or to any products and services at any time without notice.

About Microsemi

Microsemi, a wholly owned subsidiary of Microchip Technology Inc. (Nasdaq: MCHP), offers a comprehensive portfolio of semiconductor and system solutions for aerospace & defense, communications, data center and industrial markets. Products include high-performance and radiation-hardened analog mixed-signal integrated circuits, FPGAs, SoCs and ASICs; power management products; timing and synchronization devices and precise time solutions, setting the world's standard for time; voice processing devices; RF solutions; discrete components; enterprise storage and communication solutions, security technologies and scalable anti-tamper products; Ethernet solutions; Power-over-Ethernet ICs and midspans; as well as custom design capabilities and services. Learn more at www.microsemi.com.

Contents

1	Product Overview	1
1.1	Key Features	1
1.2	Block Diagram	3
2	Functional Descriptions	4
2.1	SerDes MAC Interface	4
2.2	PHY Addressing and Port Mapping	4
2.3	Cat5 Twisted Pair Media Interface	5
2.4	Reference Clock	7
2.5	Media Recovered Clock Outputs	8
2.6	Ethernet Inline-Powered Devices	8
2.7	IEEE 802.3af Power Over Ethernet Support	10
2.8	ActiPHY Power Management	10
2.9	Serial Management Interface	11
2.10	LED Interface	13
2.11	Fast Link Failure Indication	17
2.12	GPIO Pins	18
2.13	Testing Features	18
2.14	Configuration	25
3	Registers	26
3.1	Register and Bit Conventions	27
3.2	IEEE 802.3 and Main Registers	27
3.3	Extended Page 1 Registers	44
3.4	Extended Page 2 Registers	48
3.5	Extended Page 3 Registers	51
3.6	General Purpose Registers	54
3.7	Clause 45 Registers to Support Energy Efficient Ethernet and 802.3bf	63
4	Electrical Specifications	67
4.1	DC Characteristics	67
4.2	AC Characteristics	70
4.3	Operating Conditions	78
4.4	Stress Ratings	78
5	Pin Descriptions	80
5.1	Pin Identifications	80
5.2	Pin Diagram	80
5.3	Pins by Function	81
6	Package Information	86
6.1	Package Drawing	86
6.2	Thermal Specifications	88
6.3	Moisture Sensitivity	88
7	Design Considerations	89
8	Ordering Information	90

9	Revision History	91
9.1	Revision 4.2	91
9.2	Revision 4.1	91
9.3	Revision 4.0	91
9.4	Revision 2.1	91
9.5	Revision 2.0	92

1 Product Overview

The VSC8514 device is a low-power Gigabit Ethernet transceiver with copper media interfaces. It has a low electromagnetic interference (EMI) line driver, and integrated line-side termination resistors that conserve both power and printed circuit board (PCB) space.

The VSC8514 device includes Ring Resiliency™, which allows a PHY port to switch between master and slave timing references with no link drop in 1000BASE-T mode.

The VSC8514 device includes Microsemi's EcoEthernet™ 2.0 technology that supports Energy Efficient Ethernet and power saving features to reduce power based on link state and cable reach.

The VSC8514 device uses Microsemi's mixed signal and digital signal processing (DSP) architecture to ensure robust performance even under less-than-favorable environmental conditions. It supports both half-duplex and full-duplex 10BASE-T, 100BASE-TX, and 1000BASE-T communication speeds over Category 5 (Cat5) unshielded twisted pair (UTP) cable at distances greater than 100 m, displaying excellent tolerance to NEXT, FEXT, echo, and other types of ambient environmental and system electronic noise.

The VSC8514 device also includes fast link failure indication for high-availability networks. Fast link failure indication identifies the onset of a link failure in less than 1 ms typical to go beyond the IEEE 802.3 standard requirement of 750 ms ±10 ms (link master).

The following illustration shows a high-level, general view of a typical VSC8514 application.

Figure 1 • Copper Transceiver Application Diagram

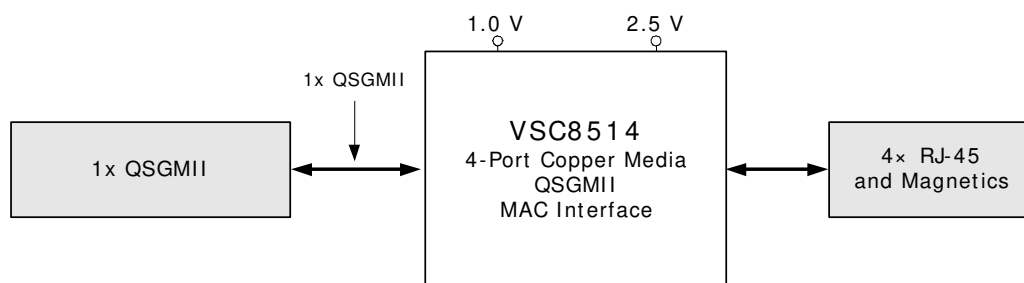

1.1 Key Features

This section lists the main features and benefits of the VSC8514 device.

1.1.1 Superior PHY and Interface Technology

- Four integrated 10/100/1000BASE-T Ethernet copper transceivers (IEEE 802.3ab-compliant) with VeriPHY™ cable diagnostics
- QSGMII SerDes MAC interface
- Patented line driver with low EMI voltage mode and integrated line side termination resistors
- HP Auto-MDIX support and forced MDI/MDIX option
- Jumbo frame support up to 16 kB with programmable synchronization FIFOs
- IEEE 802.3bf register support for standardized access to information on data delay between the MDI and xMII interface for a given PHY

1.1.2 Synchronous Ethernet Support

- Recovered clock outputs with programmable clock squelch control and fast link failure indication (<1 ms typical) for ITU-T G.8261/Y.1361 compliant Synchronous Ethernet (SyncE) applications
- 1000BASE-T Ring Resiliency to switch between master and slave timing without dropping link

1.1.3 Best-in-Class Power Consumption

- EcoEthernet™ 2.0 green energy efficiency with ActiPHY™, PerfectReach™, and IEEE 802.3az Energy Efficient Ethernet
- Fully optimized power consumption for all link speeds
- Integrated LED brightness control
- Clause 45 registers to support IEEE 802.3az Energy Efficient Ethernet and IEEE 802.3bf

1.1.4 Key Specifications

- 1.0 V and 2.5 V power supplies
- 3.3 V-tolerant 2.5 V inputs (single-ended and bi-directional TTL/CMOS I/Os)
- Compliant with IEEE 802.3 (10BASE-T, 100BASE-TX, and 1000BASE-T)
- QSGMII v1.3 and IEEE 1149.1 JTAG boundary scan
- Devices support operating temperatures of –40 °C ambient to 125 °C junction or 0 °C ambient to 125 °C junction
- Available in 12 mm x 12 mm, 138-pin, multi-row plastic QFN package

1.2 Block Diagram

The following illustration shows the primary functional blocks of the VSC8514 device.

Figure 2 • Block Diagram

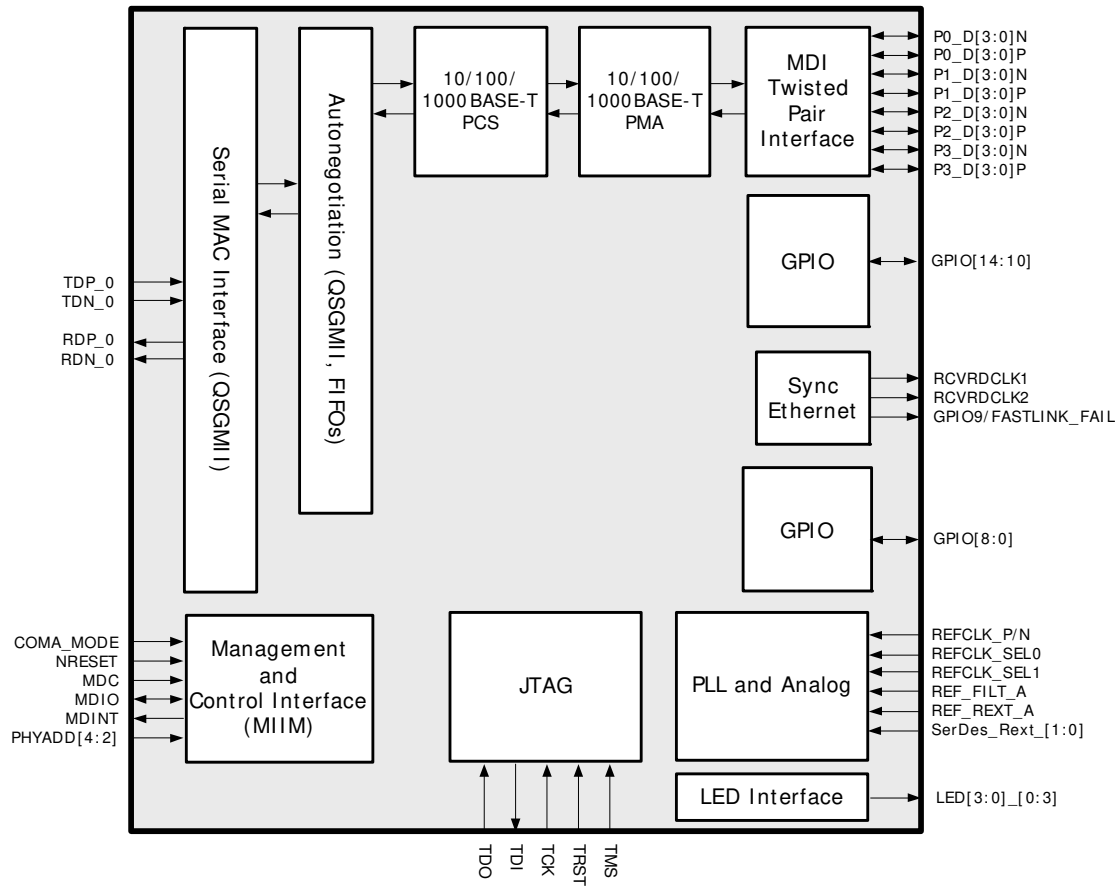

2 Functional Descriptions

This section provides detailed information about the functionality of the VSC8514 device, including available configurations, operational features, and testing functionality. It includes descriptions of the various device interfaces and their configuration. With the information in this section, the device setup parameters can be determined for configuring the VSC8514 device for use in a particular application.

2.1 SerDes MAC Interface

The VSC8514 SerDes MAC interface performs data serialization and deserialization functions using an integrated enhanced SerDes operating in QSGMII mode. The termination resistor is integrated into the enhanced SerDes block in the device but does not include integrated AC decoupling capacitors.

2.1.1 QSGMII MAC

The VSC8514 device supports a QSGMII MAC to convey four ports of network data and port speed between 10BASE-T, 100BASE-TX, and 1000BASE-T data rates and operates in both half-duplex and full-duplex at all port speeds. The MAC interface protocol for each port within QSGMII can be either 1000BASE-X or SGMII, if the QSGMII MAC that the VSC8514 is connecting to supports this functionality. The device also supports SGMII MAC-side autonegotiation on each individual port, enabled through register 16E3, bit 7, of that port.

Figure 3 • QSGMII MAC Interface

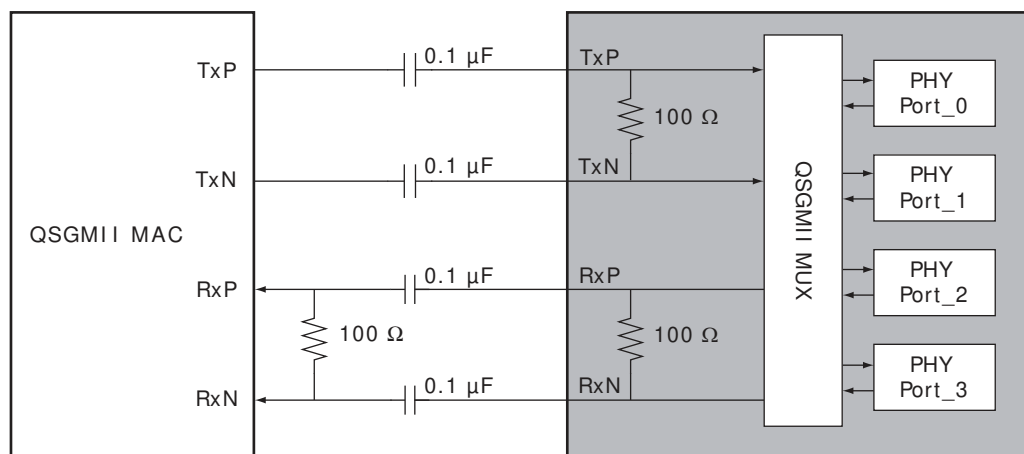

2.2 PHY Addressing and Port Mapping

The VSC8514 device includes three external PHY address pins, PHYADD[4:2], to allow control of multiple PHY devices on a system board sharing a common management bus. These pins set the most significant bits of the PHY address port map. The lower two bits of the address for each port are derived from the physical address of the port (0 to 3) and the setting of the PHY address reversal bit in register 20E1, bit 9.

The VSC8514 device also includes one 5 GHz enhanced SerDes macro operating in QSGMII mode.

2.3 Cat5 Twisted Pair Media Interface

The VSC8514 twisted pair interface is compliant with IEEE 802.3-2008 and the IEEE 802.3az standard for Energy Efficient Ethernet.

2.3.1 Voltage Mode Line Driver

The VSC8514 device uses a patented voltage mode line driver that allows it to fully integrate the series termination resistors, which are required to connect the PHY's Cat5 interface to an external 1:1 transformer. Also, the interface does not require the user to place an external voltage on the center tap of the magnetic. The following illustration shows the connections.

Figure 4 • Cat5 Media Interface

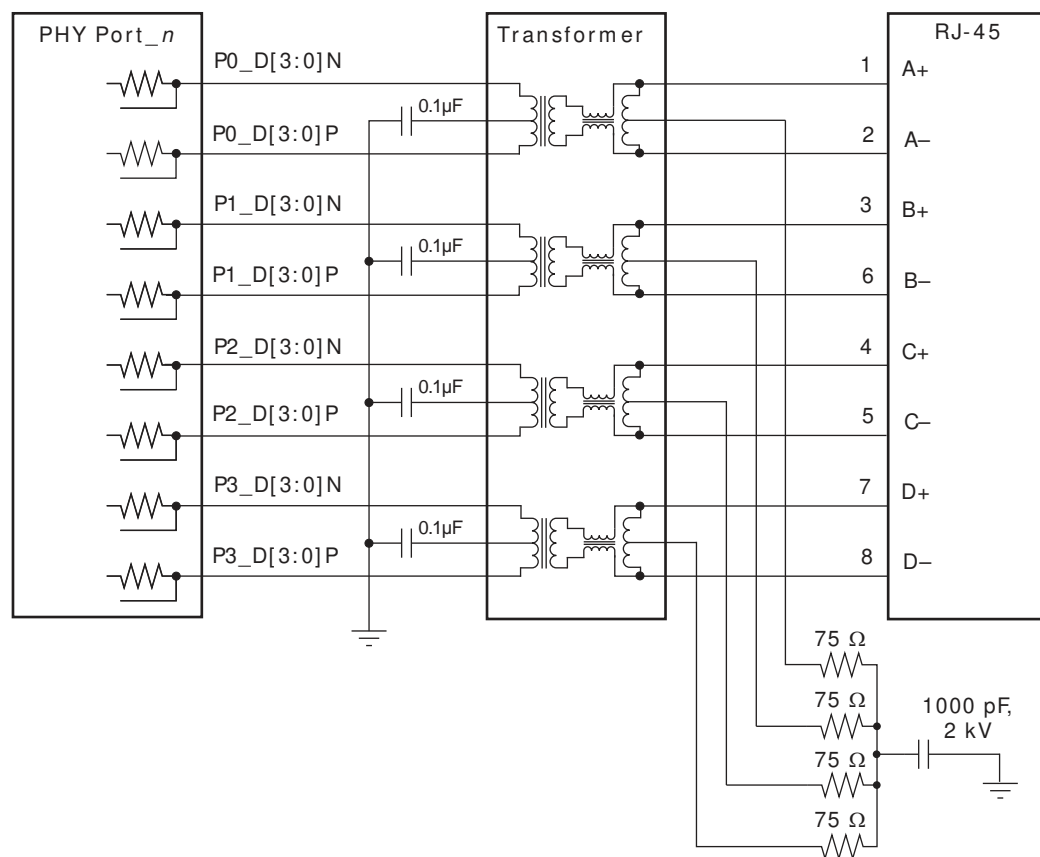

2.3.2 Cat5 Autonegotiation and Parallel Detection

The VSC8514 supports twisted pair autonegotiation, as defined by IEEE 802.3-2008 Clause 28 and IEEE 802.3az. The autonegotiation process evaluates the advertised capabilities of the local PHY and its link partner to determine the best possible operating mode. In particular, autonegotiation can determine speed, duplex configuration, and master or slave operating modes for 1000BASE-TX. Autonegotiation also enables a connected MAC to communicate with its link partner MAC through the VSC8514 using optional next pages to set attributes that may not otherwise be defined by the IEEE standard.

If the Category 5 (Cat5) link partner does not support autonegotiation, the VSC8514 automatically uses parallel detection to select the appropriate link speed.

Autonegotiation is disabled by clearing register 0, bit 12. When autonegotiation is disabled, the state of register bits 0.6, 0.13, and 0.8 determine the device operating speed and duplex mode.

Note While 10BASE-T and 100BASE-TX do not require autonegotiation, IEEE 802.3-2008 Clause 40 has defined 1000BASE-T to require autonegotiation.

2.3.3 1000BASE-T Forced Mode Support

The VSC8514 provides support for a 1000BASE-T forced test mode. In this mode, the PHY can be forced into 1000BASE-T mode and does not require manual setting of master/slave at the two ends of the link. This mode is for test purposes only, and should not be used in normal operation. To configure a PHY in this mode, set register 17E2, bit 5 = 1 and register 0, bits 6 and 13 = 10.

2.3.4 Automatic Crossover and Polarity Detection

For trouble-free configuration and management of Ethernet links, the VSC8514 includes a robust automatic crossover detection feature for all three speeds on the twisted pair interface (10BASE-T, 100BASE-T, and 1000BASE T). Known as HP Auto-MDIX, the function is fully compliant with Clause 40 of IEEE 802.3-2008.

Additionally, the device detects and corrects polarity errors on all MDI pairs — a useful capability that exceeds the requirements of the standard.

Both HP Auto-MDIX detection and polarity correction are enabled in the device by default. Default settings can be changed using device register bits 18.5:4. Status bits for each of these functions are located in register 28.

Note The VSC8514 can be configured to perform HP Auto-MDIX, even when autonegotiation is disabled and the link is forced into 10/100 speeds. To enable this feature, set register 18.7 to 0. To use the feature, also set register 0.12 to 0.

The HP Auto-MDIX algorithm successfully detects, corrects, and operates with any of the MDI wiring pair combinations listed in the following table.

Table 1 • Supported MDI Pair Combinations

1, 2	3, 6	4, 5	7, 8	Mode
A	B	C	D	Normal MDI
B	A	D	C	Normal MDI-X
A	B	D	C	Normal MDI with pair swap on C and D pair
B	A	C	D	Normal MDI-X with pair swap on C and D pair

2.3.5 Manual MDI/MDIX Setting

As an alternative to HP Auto-MDIX detection, the PHY can be forced to be MDI or MDI-X using register 19E1, bits 3:2. Setting these bits to 10 forces MDI and setting 11 forces MDI-X. Leaving the bits 00 enables the HP Auto-MDIX setting to be based on register 18, bits 7 and 5.

2.3.6 Link Speed Downshift

For operation in cabling environments that are incompatible with 1000BASE-T, the VSC8514 provides an automatic link speed downshift option. When enabled, the device automatically changes its 1000BASE-T autonegotiation advertisement to the next slower speed after a set number of failed attempts at 1000BASE-T. No reset is required to get out of this state when a subsequent link partner with 1000BASE-T support is connected. This feature is useful in setting up in networks using older cable installations that include only pairs A and B, and not pairs C and D.

To configure and monitor link speed downshifting, set register 20E1, bits 4:1. For more information, see [Table 45 on page 3-45](#).

2.3.7 Energy Efficient Ethernet

The VSC8514 supports the IEEE 802.3az Energy Efficient Ethernet standard to provide a method for reducing power consumption on an Ethernet link during times of low utilization. It uses low-power idles (LPI) to achieve this objective.

Figure 5 • Low-Power Idle Operation

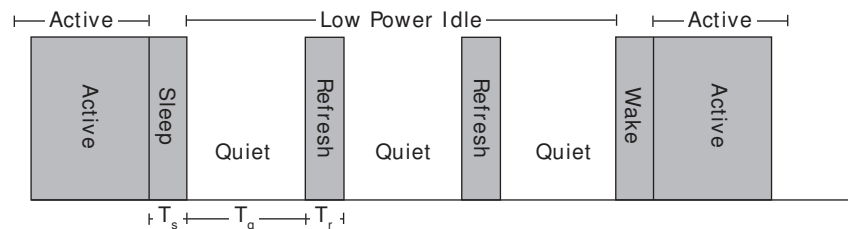

Using LPI, the usage model for the link is to transmit data as fast as possible and then return to a low-power idle state. Energy is saved on the link by cycling between active and low-power idle states. During LPI, power is reduced by turning off unused circuits and using this method, energy use scales with bandwidth utilization. The VSC8514 uses LPI to optimize power dissipation in 100BASE-TX and 1000BASE-T modes of operation.

In addition, the IEEE 802.3az standard defines a 10BASE-Te mode that reduces transmit signal amplitude from $5 V_{p-p}$ to approximately $3.3 V_{p-p}$. This mode reduces power consumption in 10 Mbps link speed and fully interoperates with legacy 10BASE-T compliant PHYs over 100 m Cat5 cable or better.

To configure the VSC8514 in 10BASE-Te mode, set register 17E2.15 to 1 for each port. Additional energy efficient Ethernet features are controlled through Clause 45 registers. For more information, see "Clause 45 Registers to Support Energy Efficient Ethernet and 802.3bf" on page 3-63.

2.3.8 Ring Resiliency

Ring resiliency changes the timing reference between the master and slave PHYs without altering the master/slave configuration in 1000BASE-T mode. The master PHY transmitter sends data based on the local clock and initiates timing recovery in the receiver. The slave PHY instructs nodes to switch the local timing reference to the recovered clock from other PHYs in the box, freezes timing recovery, and locks clock frequency for the transmitter. The master PHY makes a smooth transition to transmission from local clock to recovered clock after timing lock is achieved.

Ring resiliency can be used in synchronous Ethernet systems because the local clocks in each node are synchronized to a grandmaster clock.

Note For ring resiliency to successfully exchange master/slave timing over 1000BASE-T, the link partner must also support ring resiliency.

2.4 Reference Clock

The device reference clock supports 125 MHz and 156.25 MHz compliant clock signals. The clock signal must be capacitively coupled and LVDS compliant.

2.4.1 Configuring the Reference Clock

The REFCLK_SEL1 and REFCLK_SEL0 pins configure the reference clock speed. The following table shows the functionality and associated reference clock frequency.

Table 2 • REFCLK Frequency Selection

REFCLK_SEL1	REFCLK_SEL0	Frequency
0	0	125 MHz
1	0	156.25 MHz

2.5 Media Recovered Clock Outputs

For Synchronous Ethernet applications, the VSC8514 includes two recovered clock output pins, RCVRDCLK1 and RCVRDCLK2, controlled by registers 23G and 24G, respectively. The recovered clock pins are synchronized to the clock of the active media link.

To enable recovered clock output, set register 23G or 24G, bit 15, to 1. By default, the recovered clock output pins are disabled and held low, including when NRESET is asserted. Registers 23G and 24G also control the PHY port for clock output, the clock source, the clock frequency (either 25 MHz or 125 MHz), and squelch conditions.

2.5.1 Clock Selection Settings

On each pin, the recovered clock supports the following sources, as set by registers 23G or 24G, bits 2:0:

- Copper media
- Copper transmitter TCLK output (RCVRDCLK1 only)

Adjust the squelch level to enable 1000BASE-T master mode recovered clock for SyncE operation. This is accomplished by changing the 23G and 24G register bits 5:4 to 01. This setting also provides clock out for 10BASE-T operation. For 1000BASE-T master mode, the clock is based on the VSC8514 REFCLK input, which is a local clock.

2.5.2 Clock Output Squelch

Under certain conditions, the PHY outputs a clock based on the REFCLK_P and REFCLK_N pins, such as when there is no link present or during autonegotiation. To prevent an undesirable clock from appearing on the recovered clock pins, the VSC8514 squelches, or inhibits, the clock output based on any of the following criteria:

- No link is detected (the link status register 1, bit 2 = 0).
- The link is found to be unstable using the fast link failure detection feature. The GPIO9/FASTLINK-FAIL pin is asserted high when enabled.
- The active link is in 10BASE-T or in 1000BASE-T master mode. These modes produce unreliable recovered clock sources.
- CLK_SQUELCH_IN is enabled to squelch the clock.

Use registers 23G or 24G, bits 5:4 to configure the clock squelch criteria. These registers can also disable the squelch feature. The CLK_SQUELCH_IN pin controls the squelching of the clock. Both RCVRDCLK1 and RCVRDCLK2 are squelched when the CLK_SQUELCH_IN pin is high. This pin should not be left floating.

2.6 Ethernet Inline-Powered Devices

The VSC8514 can detect legacy inline-powered devices in Ethernet network applications. Inline-powered detection capability is useful in systems that enable IP phones and other devices (such as wireless access points) to receive power directly from their Ethernet cable, similar to office digital phones

receiving power from a private branch exchange (PBX) office switch over telephone cabling. This type of setup eliminates the need for an external power supply and enables the inline-powered device to remain active during a power outage, assuming that the Ethernet switch is connected to an uninterrupted power supply, battery, back-up power generator, or other uninterruptable power source.

For more information about legacy inline-powered device detection, visit the Cisco Web site at www.cisco.com. The following illustration shows an example of an inline-powered Ethernet switch application.

Figure 6 • Inline-Powered Ethernet Switch Diagram

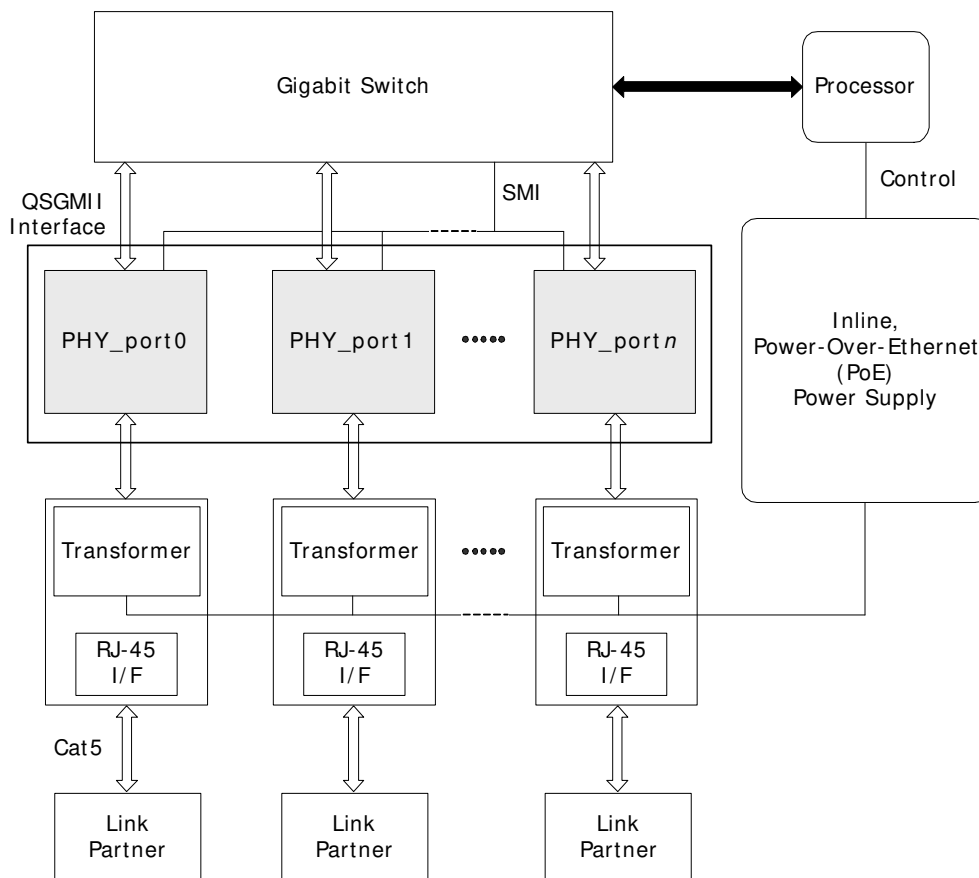

The following procedure describes the process that an Ethernet switch must perform to process inline-power requests made by a link partner that is, in turn, capable of receiving inline-power:

1. Enable the inline-powered device detection mode on each VSC8514 PHY using its serial management interface. Set register bit 23E1.10 to 1.
2. Ensure that the VSC8514 autonegotiation enable bit (register 0.12) is also set to 1. In the application, the device sends a special fast link pulse signal to the link partner. Reading register bit 23E1.9:8 returns 00 during the search for devices that require power over Ethernet (PoE).
3. The VSC8514 PHY monitors its inputs for the fast link pulse signal looped back by the link partner. A link partner capable of receiving PoE loops back the fast link pulses when the link partner is powered down. This is reported when VSC8514 register bit 23E1.9:8 reads back 01. It can also be verified as an inline-power detection interrupt by reading VSC8514 register bit 26.9, which should be a 1, and which is subsequently cleared and the interrupt de-asserted after the read. When a link partner device does not loop back the fast link pulse after a specific time, VSC8514 register bit 23E1.9:8 automatically resets to 10.
4. If the VSC8514 PHY reports that the link partner requires PoE, the Ethernet switch must enable inline-power on this port, independent of the PHY.

5. The PHY automatically disables inline-powered device detection when the VSC8514 register bits 23E1.9:8 automatically reset to 10, and then automatically changes to its normal autonegotiation process. A link is then autonegotiated and established when the link status bit is set (register bit 1.2 is set to 1).
6. In the event of a link failure (indicated when VSC8514 register bit 1.2 reads 0), it is recommended that the inline-power be disabled to the inline-powered device, independent of the PHY. The VSC8514 PHY disables its normal autonegotiation process and re-enables its inline-powered device detection mode.

2.7 IEEE 802.3af Power Over Ethernet Support

The VSC8514 device is compatible with designs that are intended for use in systems that supply power to data terminal equipment (DTE) by means of the MDI or twisted pair cable, as described in IEEE 802.3af Clause 33.

2.8 ActiPHY Power Management

In addition to the IEEE-specified power-down control bit (device register bit 0.11), the VSC8514 device also includes an ActiPHY power management mode for each PHY. This mode enables support for power-sensitive applications. It utilizes a signal-detect function that monitors the media interface for the presence of a link to determine when to automatically power-down the PHY. The PHY wakes up at a programmable interval and attempts to wake up the link partner PHY by sending a burst of fast link pulse over copper media.

The ActiPHY power management mode in the VSC8514 is enabled on a per-port basis during normal operation at any time by setting register bit 28.6 to 1.

The following operating states are possible when ActiPHY mode is enabled:

- Low-power state
- Link partner wake-up state
- Normal operating state (link-up state)

The VSC8514 switches between the low-power state and link partner wake-up state at a programmable rate (the default is two seconds) until signal energy has been detected on the media interface pins. When signal energy is detected, the PHY enters the normal operating state. If the PHY is in its normal operating state and the link fails, the PHY returns to the low-power state after the expiration of the link status time-out timer. After reset, the PHY enters the low-power state.

When autonegotiation is enabled in the PHY, the ActiPHY state machine operates as described.

When autonegotiation is disabled and the link is forced to use 10BASE-T or 100BASE-TX modes while the PHY is in its low-power state, the PHY continues to transition between the low-power and link partner wake-up states until signal energy is detected on the media pins. At that time, the PHY transitions to the normal operating state and stays in that state even when the link is dropped.

When autonegotiation is disabled while the PHY is in the normal operation state, the PHY stays in that state when the link is dropped and does not transition back to the low-power state.

The following illustration shows the relationship between ActiPHY states and timers.

Figure 7 • ActiPHY State Diagram

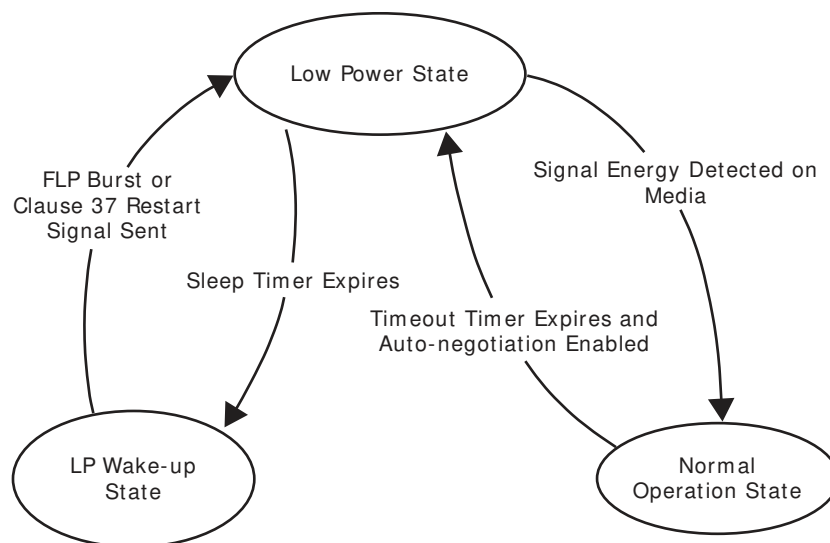

2.8.1 Low-Power State

In the low-power state, all major digital blocks are powered down. However, the SMI interface (MDC, MDIO, and MDINT) functionality is provided.

In this state, the PHY monitors the media interface pins for signal energy. The PHY comes out of low-power state and transitions to the normal operating state when signal energy is detected on the media. This happens when the PHY is connected to one of the following:

- Autonegotiation-capable link partner
- Another PHY in enhanced ActiPHY link partner wake-up state

In the absence of signal energy on the media pins, the PHY periodically transitions from low-power state to link partner wake-up state, based on the programmable sleep timer (register bits 20E1.14:13). The actual sleep time duration is randomized from –80 ms to 60 ms to avoid two linked PHYs in ActiPHY mode entering a lock-up state during operation.

2.8.2 Link Partner Wake-Up State

In the link partner wake-up state, the PHY attempts to wake up the link partner. Up to three complete fast link pulse bursts are sent on alternating pairs A and B of the Cat5 media for a duration based on the wake-up timer, which is set using register bits 20E1.12:11.

In this state, SMI interface (MDC, MDIO, and MDINT) functionality is provided.

After sending signal energy on the relevant media, the PHY returns to the low-power state.

2.8.3 Normal Operating State

In the normal operating state, the PHY establishes a link with a link partner. When the media is unplugged or the link partner is powered down, the PHY waits for the duration of the programmable link status time-out timer, which is set using register bit 28.7 and bit 28.2. It then enters the low-power state.

2.9 Serial Management Interface

The VSC8514 device includes an IEEE 802.3-compliant serial management interface (SMI) that is controlled by its MDC, MDIO, and MDINT pins. The SMI provides access to device control and status registers. The register set that controls the SMI consists of 32 16-bit registers, including all required

IEEE-specified registers. Also, there are additional pages of registers accessible using device register 31.

Energy efficient Ethernet control registers are available through the SMI using Clause 45 registers and Clause 22 register access in registers 13 through 14. For information about available register settings, see [Table 24 on page 3-34](#) and [Table 70 on page 3-63](#).

The SMI is a synchronous serial interface with input data to the VSC8514 on the MDIO pin that is clocked on the rising edge of the MDC pin. The output data is sent on the MDIO pin on the rising edge of the MDC signal. The interface can be clocked at a rate from 0 MHz to 12.5 MHz, depending on the total load on MDIO. An external 2-k Ω pull-up resistor is required on the MDIO pin.

2.9.1 SMI Frames

Data is transferred over the SMI using 32-bit frames with an optional, arbitrary-length preamble. Before the first frame can be sent, at least two clock pulses on MDC must be provided with the MDIO signal at logic one to initialize the SMI state machine. The following illustrations show the SMI frame format for read and write operations.

Figure 8 • SMI Read Frame

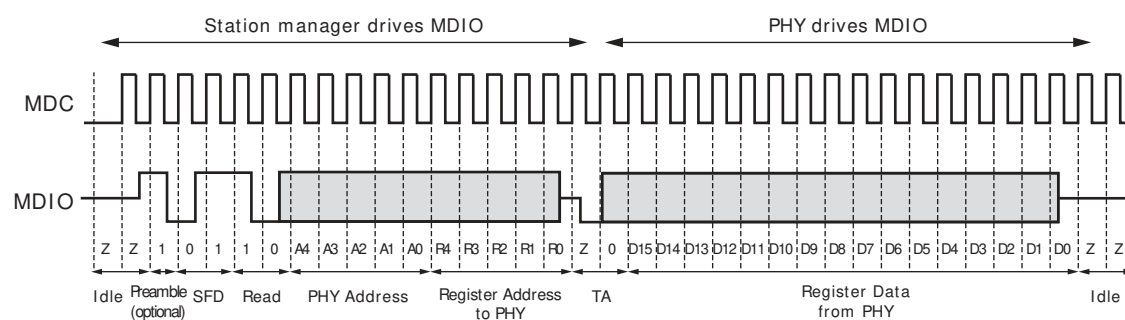
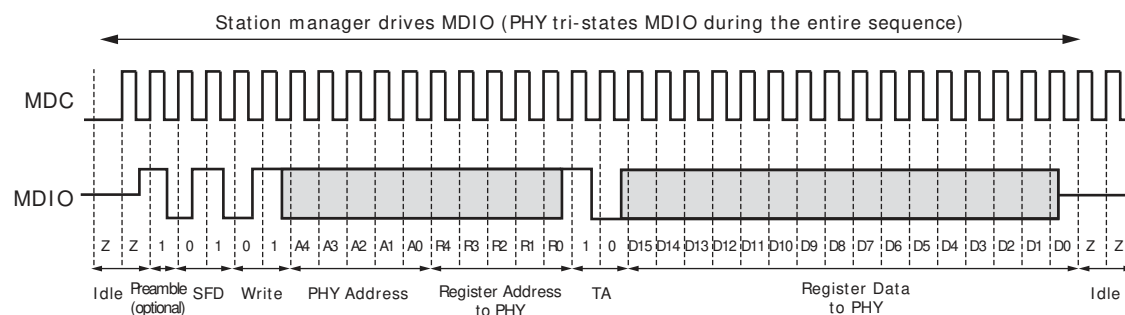

Figure 9 • SMI Write Frame



The following list defines the terms used in the SMI read and write timing diagrams.

- **Idle** During idle, the MDIO node goes to a high-impedance state. This allows an external pull-up resistor to pull the MDIO node up to a logical 1 state. Because the idle mode does not contain any transitions on MDIO, the number of bits is undefined during idle.
- **Preamble** By default, preambles are not expected or required. The preamble is a string of ones. If it exists, the preamble must be at least 1 bit; otherwise, it can be of an arbitrary length.
- **Start of Frame Delimiter (SFD)** A pattern of 01 indicates the start of frame. If the pattern is not 01, all following bits are ignored until the next preamble pattern is detected.
- **Read or Write Opcode** A pattern of 10 indicates a read. A 01 pattern indicates a write. If the bits are not either 01 or 10, all following bits are ignored until the next preamble pattern is detected.
- **PHY Address** The particular VSC8514 device responds to a message frame only when the received PHY address matches its physical address. The physical address is 5 bits long (4:0).

- **Register Address** The next five bits are the register address.
- **Turnaround** The two bits used to avoid signal contention when a read operation is performed on the MDIO are called the turnaround (TA) bits. During read operations, the VSC8514 device drives the second TA bit, a logical 0.
- **Data** The 16-bits read from or written to the device are considered the data or data stream. When data is read from a PHY, it is valid at the output from one rising edge of MDC to the next rising edge of MDC. When data is written to the PHY, it must be valid around the rising edge of MDC.
- **Idle** The sequence is repeated.

2.9.2 SMI Interrupt

The SMI includes an output interrupt signal, MDINT, for signaling the station manager when certain events occur in the VSC8514.

When a PHY generates an interrupt, the MDINT pin is asserted if the interrupt pin enable bit (MII register 25.15) is set. The MDINT pin can be configured for open-drain (active-low) by tying the pin to a pull-up resistor and to VDDIO. The following illustration shows this configuration.

Figure 10 • MDINT Configured as an Open-Drain (Active-Low) Pin

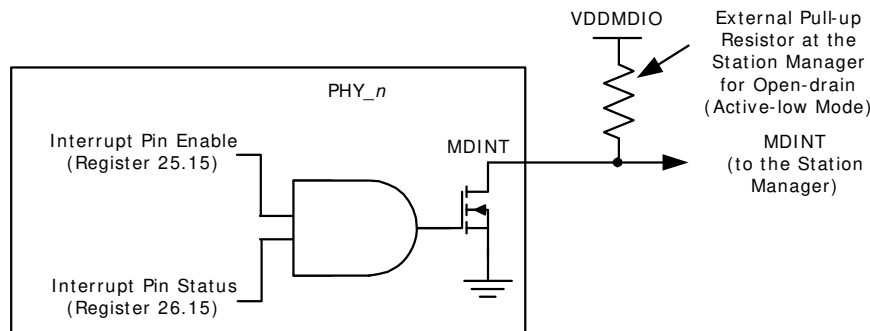

2.10 LED Interface

The LED interface supports the following configurations: direct drive, basic serial LED mode, and enhanced serial LED mode. The polarity of the LED outputs is programmable and can be changed using register 17E2, bits 13:10. The default polarity is active low.

Direct drive mode provides four LED signals per port, LED0_[0:3] through LED3_[0:3]. The mode and function of each LED signal can be configured independently. When serial LED mode is enabled, the direct drive pins not used by the serial LED interface remain available.

In basic serial LED mode, all signals that can be displayed on LEDs are sent as LED_Data and LED_CLK for external processing.

In enhanced serial LED mode, up to four LED signals per port can be sent as LED_Data, LED_CLK, LED_LD, and LED_Pulse. The following sections provide detailed information about the various LED modes.

Note LED number is listed using the convention, LED<LED#>_<Port#>.

The following table shows the bit 9 settings for register 14G that are used to control the LED behavior for all the LEDs in VSC8514.

Table 3 • LED Drive State

Setting	Active	Not Active
14G[9: 1] (default)	Ground	Tristate
14G[9: 0] (alternate setting)	Ground	Vdd

2.10.1 LED Modes

Each LED pin can be configured to display different status information that can be selected by setting the LED mode in register 29. The default LED state is active low but can be changed by modifying the value in register 17E2, bits 13:10. The blink/pulse stretch is dependent on the LED behavior setting in register 30.

The following table provides a summary of the LED modes and functions. The modes listed are equivalent to the setting used in register 29 to configure each LED pin.

Table 4 • LED Mode and Function Summary

Mode	Function Name	LED State and Description
0	Link/Activity	1: No link in any speed on any media interface. 0: Valid link at any speed on any media interface. Blink or pulse-stretch = Valid link at any speed on any media interface with activity present.
1	Link1000/Activity	1: No link in 1000BASE-T. 0: Valid 1000BASE-T. Blink or pulse-stretch = Valid 1000BASE-T link with activity present.
2	Link100/Activity	1: No link in 100BASE-TX. 0: Valid 100BASE-TX. Blink or pulse-stretch = Valid 100BASE-TX link with activity present.
3	Link10/Activity	1: No link in 10BASE-T. 0: Valid 10BASE-T link. Blink or pulse-stretch = Valid 10BASE-T link with activity present.
4	Link100/1000/Activity	1: No link in 100BASE-TX or 1000BASE-T. 0: Valid 100BASE-TX or 1000BASE-T link. Blink or pulse-stretch = Valid 100BASE-TX or 1000BASE-T link with activity present.
5	Link10/1000/Activity	1: No link in 10BASE-T or 1000BASE-T. 0: Valid 10BASE-T or 1000BASE-T link. Blink or pulse-stretch = Valid 10BASE-T or 1000BASE-T link with activity present.
6	Link10/100/Activity	1: No link in 10BASE-T or 100BASE-TX. 0: Valid 10BASE-T or 100BASE-TX, link. Blink or pulse-stretch = Valid 10BASE-T or 100BASE-TX link with activity present.

Table 4 • LED Mode and Function Summary (continued)

Mode	Function Name	LED State and Description
7	Reserved	Reserved
8	Duplex/Collision	1: Link established in half-duplex mode, or no link established. 0: Link established in full-duplex mode. Blink or pulse-stretch = Link established in half-duplex mode but collisions are present.
9	Collision	1: No collision detected. Blink or pulse-stretch = Collision detected.
10	Activity	1: No activity present. Blink or pulse-stretch = Activity present (becomes TX activity present when register bit 30.14 is set to 1).
11	Reserved	Reserved
12	Autonegotiation Fault	1: No autonegotiation fault present. 0: Autonegotiation fault occurred.
13	Serial Mode	Serial stream. See "Basic Serial LED Mode" on page 2-15 . Only relevant on PHY port 0. Reserved in others.
14	Force LED Off	1: De-asserts the LED ⁽¹⁾ .
15	Force LED On	0: Asserts the LED ⁽¹⁾ .

1. Setting this mode suppresses LED blinking after reset.

2.10.2 Basic Serial LED Mode

The VSC8514 can be configured so that access to all its LED signals is available using two pins. This option is enabled by setting LED0 on PHY0 to serial LED mode in register 29, bits 3:0 to 0xD. When serial LED mode is enabled, the LED0_0 pin becomes the serial data pin, and the LED1_0 pin becomes the serial clock pin. All other LED pins can still be configured normally. The serial LED mode clocks the 48 LED status bits on the rising edge of the serial clock.

The LED behavior settings can also be used in serial LED mode. The controls are used on a per-PHY basis, where the LED combine and LED blink or pulse-stretch setting of LED0_n for each PHY is used to control the behavior of each bit of the serial LED stream for each corresponding PHY. To configure LED behavior, set device register 30.

The following table shows the 48-bit serial output bitstream of each LED signal. The individual signals can be clocked in the following order.

Table 5 • LED Serial Bitstream Order

Output	PHY0	PHY1	PHY2	PHY3
Link/activity	1	13	25	37
Link1000/activity	2	14	26	38
Link100/activity	3	15	27	39
Link10/activity	4	16	28	40
Reserved	5	17	29	41
Duplex/collision	6	18	30	42
Collision	7	19	31	43
Activity	8	20	32	44

Table 5 • LED Serial Bitstream Order (continued)

Output	PHY0	PHY1	PHY2	PHY3
Reserved	9	21	33	45
Tx activity	10	22	34	46
Rx activity	11	23	35	47
Autonegotiation fault	12	24	36	48

2.10.3 Enhanced Serial LED Mode

The VSC8514 device can be configured to output up to four LED signals per port on a serial stream that can be de-serialized externally to drive LEDs on the system board. In enhanced serial LED mode, the port 0 and port 1 LED output pins serve the following functions:

- LED0_0/LED0_1: LED_DATA
- LED1_0/LED1_1: LED_CLK
- LED2_0/LED2_1: LED_LD
- LED3_0/LED3_1: LED_PULSE

The serial LED_DATA is shifted out on the falling edge of LED_CLK and is latched in the external serial-to-parallel converter on the rising edge of LED_CLK. The falling edge of LED_LD can be used to shift the data from the shift register in the converter to the parallel output drive register. When a separate parallel output drive register is not used in the external serial-to-parallel converter, the LEDs blink at a high frequency while the data bits are shifted through, which may be undesirable. LED pin functionality is controlled by setting register 25G, bits 7:1.

The LED_PULSE signal provides a 5 kHz pulse stream whose duty cycle can be modulated to turn off/on LEDs at a high rate. This signal can be tied to the output enable signal of the serial-to-parallel converter to provide the LED dimming functionality to save energy. The LED_PULSE duty cycle is controlled by setting register 25G, bits 15:8.

2.10.4 Extended LED Modes

In addition to the LED modes in register 29, extended LED modes are enabled on the LED0_[3:0] pins when the corresponding register 19E1, bits 15 to 12 are set to 1. Each of these bits enables extended modes on a specific LED pin, and these extended modes are shown in the following table. For example, LED0 = mode 17 means that register 19E1 bit 12 = 1 and register 29 bits 3 to 0 = 0001.

The following table provides a summary of the extended LED modes and functions.

Table 6 • Extended LED Mode and Function Summary

Mode	Function Name	LED State and Description
16	Link1000BASE-X Activity	1: No link in 1000BASE-X. 0: Valid 1000BASE-X link.
17	Link100BASE-FX Activity	1: No link in 100BASE-FX. 0: Valid 100BASE-FX link.
18	1000BASE-X Activity	1: No 1000BASE-X activity present. Blink or pulse-stretch = 1000BASE-X activity present.
19	100BASE-FX Activity	1: No 100BASE-FX activity present. Blink or pulse-stretch = 100BASE-FX activity present.
20	Force LED Off	1: De-asserts the LED.
21	Force LED On	0: Asserts the LED. LED pulsing is disabled in this mode.

Table 6 • Extended LED Mode and Function Summary (continued)

Mode	Function Name	LED State and Description
22	Fast Link Fail	1: Enable fast link fail on the LED pin 0: Disable

2.10.5 LED Port Swapping

For additional hardware configurations, the VSC8514 can have its LED port order swapped. This is a useful feature to help simplify PCB layout design. Register 25G bit 0 controls the LED port swapping mode.

2.10.6 LED Behavior

Several LED behaviors can be programmed into the VSC8514. Use the settings in register 30 and 19E1 to program LED behavior, which includes the following:

2.10.6.1 LED Combine

Enables an LED to display the status for a combination of primary and secondary modes. This can be enabled or disabled for each LED pin. For example, a copper link running in 1000BASE-T mode and activity present can be displayed with one LED by configuring an LED pin to Link1000/Activity mode. The LED asserts when linked to a 1000BASE-T partner and also blinks or performs pulse-stretch when activity is either transmitted by the PHY or received by the Link Partner. When disabled, the combine feature only provides status of the selected primary function. In this example, only Link1000 asserts the LED, and the secondary mode, activity, does not display when the combine feature is disabled.

2.10.6.2 LED Blink or Pulse-Stretch

This behavior is used for activity and collision indication. This can be uniquely configured for each LED pin. Activity and collision events can occur randomly and intermittently throughout the link-up period. Blink is a 50% duty cycle oscillation of asserting and de-asserting an LED pin. Pulse-stretch guarantees that an LED is asserted and de-asserted for a specific period of time when activity is either present or not present. These rates can also be configured using a register setting.

2.10.6.3 Rate of LED Blink or Pulse-Stretch

This behavior controls the LED blink rate or pulse-stretch length when blink/pulse-stretch is enabled on an LED pin. The blink rate, which alternates between a high and low voltage level at a 50% duty cycle, can be set to 2.5 Hz, 5 Hz, 10 Hz, or 20 Hz. For pulse-stretch, the rate can be set to 50 ms, 100 ms, 200 ms, or 400 ms. The blink rate selection for PHY0 globally sets the rate used for all LED pins on all PHY ports.

2.10.6.3.1 LED Pulsing Enable

To provide additional power savings, the LEDs (when asserted) can be pulsed at 5 kHz, 20% duty cycle.

2.10.6.3.2 LED Blink After Reset

The LEDs will blink for one second after power-up and after any time all resets have been de-asserted. This can be disabled through register 19E1, bit 11 = 0.

2.10.6.3.3 Pulse Programmable Control

These bits add the ability to width and frequency of LED pulses. This feature facilitates power reduction options.

2.11 Fast Link Failure Indication

The VSC8514 device exceeds IEEE 802.3 standards by indicating the onset of a link failure in less than 1 ms (worst case <3 ms). (IEEE 802.3 standard establishes a delay of up to 750 ms before indicating that a 1000BASE-T link is no longer present.) A fast link failure indication is critical to support ports used in a synchronization timing link application. The fast link failure indication works for all copper media speeds. Fast link failure is supported for each PHY port through the GPIO9/FASTLINK-FAIL pin.

Note For all links except 1000BASE-T, the fast link failure indication matches the link status register (address 1, bit 2). For 1000BASE-T links, the link failure is based on a circuit that analyzes the integrity of the link, and asserts at the indication of failure.

2.12 GPIO Pins

The VSC8514 provides 15 multiplexed general purpose input/output (GPIO) pins. All device GPIO pins and their behavior are controlled using registers. The following table shows an overview of the register controls for GPIO pins. For more information, see "General Purpose Registers" on page 3-54.

Table 7 • Register Bits for GPIO Control and Status

GPIO Pin	GPIO_ctrl	GPIO Input	GPIO Output	GPIO Output Enable
GPIO0	13G[1:0]	15G.0	16G.0	17G.0
GPIO1	13G[3:2]	15G.1	16G.1	17G.1
GPIO2	13G[5:4]	15G.2	16G.2	17G.2
GPIO3	13G[7:6]	15G.3	16G.3	17G.3
GPIO4	13G[9:8]	15G.4	16G.4	17G.4
GPIO5	13G[11:10]	15G.5	16G.5	17G.5
GPIO6	13G[13:12]	15G.6	16G.6	17G.6
GPIO7	13G[15:14]	15G.7	16G.7	17G.7
GPIO8	14G[1:0]	15G.8	16G.8	17G.8
GPIO9	14G[3:2]	15G.9	16G.9	17G.9
GPIO10	14G[5:4]	15G.10	16G.10	17G.10
GPIO11	14G[7:6]	15G.11	16G.11	17G.11
GPIO12	14G[15:14]	15G.12	16G.12	17G.12
GPIO13	14G[15:14]	15G.13	16G.13	17G.13
GPIO14	14G[15:14]	15G.14	16G.14	17G.14

2.13 Testing Features

The VSC8514 device includes several testing features designed to facilitate performing system-level debugging and in-system production testing. This section describes the available features.

2.13.1 Ethernet Packet Generator

The Ethernet packet generator (EPG) can be used at each of the 10/100/1000BASE-T speed settings for copper Cat5 media to isolate problems between the MAC and the VSC8514, or between a locally connected PHY and its remote link partner. Enabling the EPG feature disables all MAC interface transmit pins and selects the EPG as the source for all data transmitted onto the twisted pair interface.

Important The EPG is intended for use with laboratory or in-system testing equipment only. Do not use the EPG testing feature when the VSC8514 is connected to a live network.

To enable the VSC8514 EPG feature, set the device register bit 29E1.15 to 1.

When the EPG is enabled, packet loss occurs during transmission of packets from the MAC to the PHY. However, the PHY receive output pins to the MAC are still active when the EPG is enabled. When it is necessary to disable the MAC receive pins as well, set the register bit 0.10 to 1.

When the device register bit 29E1.14 is set to 1, the PHY begins transmitting Ethernet packets based on the settings in registers 29E1 and 30E1. These registers set:

- Source and destination addresses for each packet
- Packet size
- Interpacket gap
- FCS state
- Transmit duration
- Payload pattern

When register bit 29E1.13 is set to 0, register bit 29E1.14 is cleared automatically after 30,000,000 packets are transmitted.

2.13.2 CRC Counters

Two sets of cyclical redundancy check (CRC) counters are available in all PHYs in VSC8514. One set monitors traffic on the copper interface, and the other set monitors traffic on the SerDes interface.

The device CRC counters operate in the 10/100/1000BASE-T mode as follows:

- After receiving a packet on the media interface, register bit 15 in register 18E1 is set and cleared after being read.
- The packet then is counted by either the good CRC counter or the bad CRC counter.
- Both CRC counters are also automatically cleared when read.
- The good CRC counter's highest value is 9,999 packets. After this value is reached, the counter clears on the 10,000th packet and continues to count additional packets beyond that value.
- The bad CRC counter stops counting when it reaches its maximum counter limit of 255 packets.

2.13.2.0.1 Copper Interface CRC Counters

Two separate CRC counters are available between the copper interface PCSs and SerDes MAC interface. There is a 14-bit good CRC counter available through register bits 18E1.13:0 and a separate 8-bit bad CRC counter available in register bits 23E1.7:0.

2.13.3 Far-End Loopback

The far-end loopback testing feature is enabled by setting register bit 23.3 to 1. When enabled, it forces incoming data from a link partner on the current media interface into the MAC interface of the PHY where it is retransmitted to the link partner on the media interface as shown in the following illustration. In addition, the incoming data also appears on the receive data pins of the MAC interface. Data present on the transmit data pins of the MAC interface is ignored when using this testing feature.

Figure 11 • Far-End Loopback Diagram

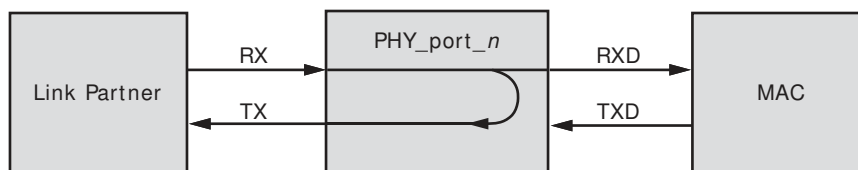

2.13.4 Near-End Loopback

When the near-end loopback testing feature is enabled, transmitted data (TXD) is looped back in the PCS block onto the receive data signals (RXD), as shown in the following illustration. When using this testing feature, no data is transmitted over the network. To enable near-end loopback, set the device register bit 0.14 to 1.

Figure 12 • Near-End Loopback Diagram

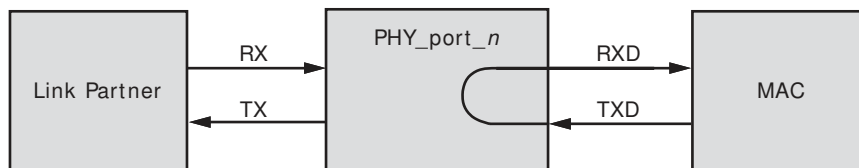

2.13.5 Connector Loopback

The connector loopback testing feature allows the twisted pair interface to be looped back externally. When using this feature, the PHY must be connected to a loopback connector or a loopback cable. Connect pair A to pair B, and pair C to pair D, as shown in the following illustration. The connector loopback feature functions at all available interface speeds.

Figure 13 • Connector Loopback Diagram

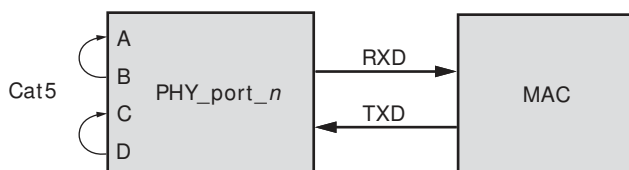

When using the connector loopback testing feature, the device autonegotiation, speed, and duplex configuration is set using device registers 0, 4, and 9.

For 1000BASE-T connector loopback, additional writes are required in the following order:

1. Enable the 1000BASE-T connector loopback. Set register bit 24.0 to 1.
2. Disable pair swap correction. Set register bit 18.5 to 1.

2.13.6 SerDes Loopbacks

For test purposes, the SerDes and SerDes macro interfaces provides several data loops. The following illustration shows the SerDes loopbacks.

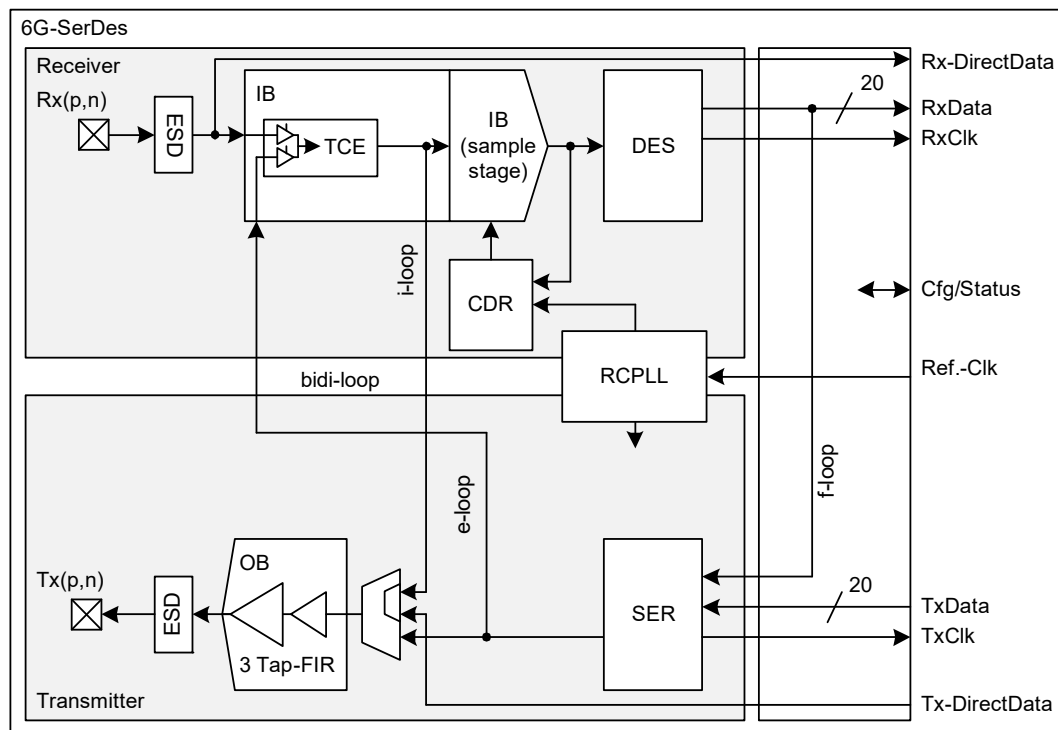
Figure 14 • Data Loops of the SerDes Macro

2.13.6.1 QSGMII Mode

When the MAC interface is configured in QSGMII mode, write the following 16-bit value to register 18G:

Bits 15:12 0x9

Bits 11:8: Port address (0x0)

Bits 7:4: Loopback type

0x0: No loopback

0x2: Input loopback

0x4: Facility loopback

0x8: Equipment loopback

Bits 3:0: 0x2

Note Loopback configuration affects all ports associated with a QSGMII. Individual port loopback within a QSGMII is not possible.

2.13.6.1.1 Facility Loop

The recovered and de-multiplexer deserializer data output is looped back to the serializer data input and replaces the data delivered by the digital core. This test loop provides the possibility to test the complete analog macro data path from outside including input buffer, clock and data recovery, serialization and output buffer. The data received by the input buffer must be transmitted by the output buffer after some delay.

Additional configuration of the enhanced SerDes macro is required when selecting facility loopback mode. Run the “set = 1” option when entering facility loopback mode and the “set = 0” option when exiting facility loopback mode. Execute this additional configuration after running the command to enable/disable facility loopback mode.

```
PhyWrite (PhyBaseAddr, 31, 0x0010);
PhyWrite (PhyBaseAddr, 18, 0x8013);
PhyWrite (PhyBaseAddr, 18, 0xd7cb);
```

```

PhyWrite(PhyBaseAddr, 18, 0x8007);
tmp1 = PhyRead(PhyBaseAddr, 18);
tmp2 = tmp1 & 0x0ff0;
if (set)
    tmp3 = tmp2 | 0x0100;
else
    tmp3 = tmp2 & 0x0ef0;
tmp4 = tmp3 | 0x8006;
PhyWrite(PhyBaseAddr, 18, tmp4);
PhyWrite(PhyBaseAddr, 18, 0x9c40);
// PhyBaseAddr is the 5-bit base address of the internal PHYs.
// The upper 3 bits are set by the PHYADD[4:2] pins and the
// lower 2 bits are 0.

```

2.13.6.1.2 Equipment Loop

The 1-bit data stream at the serializer output is looped back to the deserializer and replaces the received data stream from the input buffer. This test loop provides the possibility to verify the digital data path internally. The transmit data goes through the serialization, the clock and data recovery, and deserialization before the data is fed back to the digital core.

2.13.6.1.3 Input Loop

The received 1-bit data stream of the input buffer is looped back asynchronously to the output buffer. This test loop provides the possibility to test only the analog parts of the QSGMII interface because only the input and output buffer are part of this loop.

2.13.7 VeriPHY Cable Diagnostics

The VSC8514 includes a comprehensive suite of cable diagnostic functions that are available using SMI reads and writes. These functions enable a variety of cable operating conditions and status to be accessed and checked. The VeriPHY suite has the ability to identify the cable length and operating conditions and to isolate a variety of common faults that can occur on Cat5 twisted pair cabling.

For functional details of the VeriPHY suite and the operating instructions, see the ENT-AN0125 PHY, Integrated PHY-Switch VeriPHY - Cable Diagnostics application note.

2.13.8 JTAG Boundary Scan

The VSC8514 supports the test access port (TAP) and boundary scan architecture described in IEEE 1149.1. The device includes an IEEE 1149.1-compliant test interface, referred to as a JTAG TAP interface.

The JTAG boundary scan logic on the VSC8514, accessed using its TAP interface, consists of a boundary scan register and other logic control blocks. The TAP controller includes all IEEE-required signals (TMS, TCK, TDI, and TDO), in addition to the optional asynchronous reset signal TRST. The following illustration shows the TAP and boundary scan architecture.

Important When JTAG is not in use, the TRST pin must be tied to ground with a pull-down resistor for normal operation.

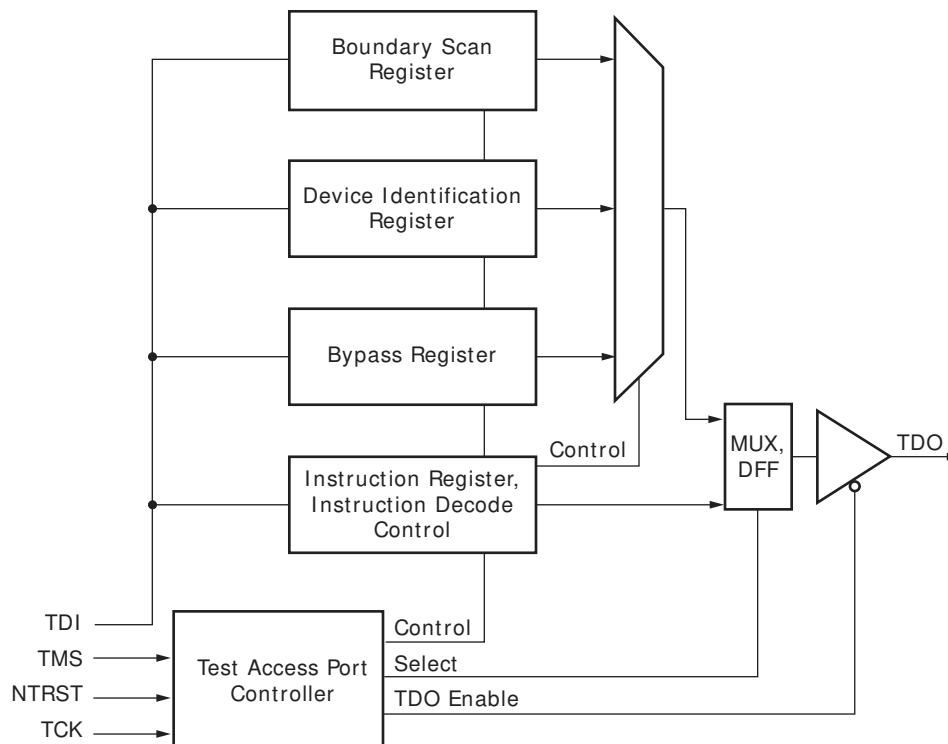
Figure 15 • Test Access Port and Boundary Scan Architecture

After a TAP reset, the device identification register is serially connected between TDI and TDO by default. The TAP instruction register is loaded from a shift register when a new instruction is shifted in, or if there is no new instruction in the shift register, a default value of 6'b100100 (IDCODE) is loaded. Using this method, there is always a valid code in the instruction register, and the problem of toggling instruction bits during a shift is avoided. Unused codes are mapped to the BYPASS instruction.

2.13.9 JTAG Instruction Codes

The following table shows the supported JTAG instruction codes.

Table 8 • JTAG Instruction Codes

Instruction Code	Description
BYPASS	The bypass register contains a single shift-register stage and is used to provide a minimum-length serial path (one TCK clock period) between TDI and TDO to bypass the device when no test operation is required.
CLAMP	Allows the state of the signals driven from the component pins to be determined from the boundary scan register while the bypass register is selected as the serial path between TDI and TDO. While the CLAMP instruction is selected, the signals driven from the component pins do not change.
EXTEST	Allows tests of the off-chip circuitry and board-level interconnections by sampling input pins and loading data onto output pins. Outputs are driven by the contents of the boundary scan cells, which have to be updated with valid values, with the PRELOAD instruction, prior to the EXTEST instruction.

Table 8 • JTAG Instruction Codes (continued)

Instruction Code	Description
HIGHZ	Places the component in a state in which all of its system logic outputs are placed in a high-impedance state. In this state, an in-circuit test system can drive signals onto the connections normally driven by a component output without incurring a risk of damage to the component. This makes it possible to use a board where not all of the components are compatible with the IEEE 1149.1 standard.
IDCODE	Provides the version number (bits 31:28), device family ID (bits 27:12), and the manufacturer identity (bits 11:1) to be serially read from the device.
SAMPLE/PRELOAD	Allows a snapshot of inputs and outputs during normal system operation to be taken and examined. It also allows data values to be loaded into the boundary scan cells prior to the selection of other boundary scan test instructions.
USERCODE	Provides the version number (bits 31:28), part number (bits 27:12), and the manufacturer identity (bits 11:1) to be serially read from the device.

The following table provides information about the USERCODE binary values stored in the device JTAG register.

Table 9 • USERCODE JTAG Device Identification Register Descriptions

Description	Device Version	Family ID	Manufacturing Identity	LSB
Bit field	31–28	27–12	11–1	0
Binary value	0000	1000 0101 0001 0100	000 0111 0100	1

The following table provides information about the location and IEEE compliance of the JTAG instruction codes used in the VSC8514. Instructions not explicitly listed in the table are reserved. For more information about these IEEE specifications, visit the IEEE Web site at www.IEEE.org.

Table 10 • JTAG Instruction Code IEEE Compliance

Instruction	Code	Selected Register	Register Width	IEEE 1149.1
EXTEST	6'b000000	Boundary Scan	161	Mandatory
SAMPLE/PRELOAD	6'b000001	Boundary Scan	161	Mandatory
IDCODE	6'b100100	Device Identification	32	Optional
USERCODE	6'b100101	Device Identification	32	Optional
CLAMP	6'b000010	Bypass Register	1	Optional
HIGHZ	6'b000101	Bypass Register	1	Optional
BYPASS	6'b111111	Bypass Register	1	Mandatory

2.13.10 Boundary Scan Register Cell Order

All inputs and outputs are observed in the boundary scan register cells. All outputs are additionally driven by the contents of boundary scan register cells. Bidirectional pins have all three related boundary scan register cells: input, output, and control.

The complete boundary scan cell order is available as a BSDL file on the Microsemi Web site.

2.14 Configuration

The VSC8514 can be configured by setting internal memory registers using the management interface. To configure the device, perform the following steps:

1. COMA_MODE active, drive high.
2. Apply power.
3. Apply RefClk.
4. Release reset, drive high. Power and clock must be stable before releasing reset.
5. Wait 120 ms, minimum.
6. Apply patch from PHY_API.
7. Configure register 19G for MAC mode (to access register 19G, register 31 must be 0x10). Read register 19G. Set bits 15:14, MAC configuration, to 01:
Write new register 19G.
8. Configure register 18G for MAC on all 4 PHYs write:
QSGMII: 0x80E0
Read register 18G until bit 15 equals 0.
9. Configure register 23 for MAC and Media mode (to access register 23, register 31 must be 0).
Read register 23. Set bits 10:8 to 000:
Write new register 23.
10. Software reset. Read register 0 (to access register 0, register 31 must be 0). Set bit 15 to 1.
Write new register 0.
11. Read register 0 until bit 15 equals 0.
12. Release the COMA_MODE pin, drive low.

2.14.1 Initialization

The COMA_MODE pin provides an optional feature that may be used to control when the PHYs become active. The typical usage is to keep the PHYs from becoming active before they have been fully initialized. For more information, see "[Configuration](#)" on [page 2-25](#). Alternatively the COMA_MODE pin may be connected low (ground) so that the PHYs are fully active once out of reset.

3 Registers

This section provides information about how to configure the VSC8514 device using its internal memory registers and the management interface. The registers marked reserved and factory test should not be read or written to, because doing so may produce undesired effects.

The default value documented for registers is based on the value at reset; however, in some cases, that value may change immediately after reset.

The access type for each register is shown using the following abbreviations:

- RO: Read Only
- ROCR: Read Only, Clear on Read
- RO/LH: Read Only, Latch High
- RO/LL: Read Only, Latch Low
- RW: Read and Write
- RWSC: Read Write Self Clearing

The VSC8514 device uses several different types of registers:

- IEEE Clause 22 device registers with addresses from 0 to 31
- Three pages of extended registers with addresses from 16E1–30E1, 16E2–30E2, and 16E3–30E3
- General-purpose registers with addresses from 0G to 30G
- IEEE Clause 45 devices registers accessible through the Clause 22 registers 13 and 14 to support IEEE 802.3az energy efficient Ethernet registers

The following illustration shows the relationship between the device registers and their address spaces.

Figure 16 • Register Space Diagram

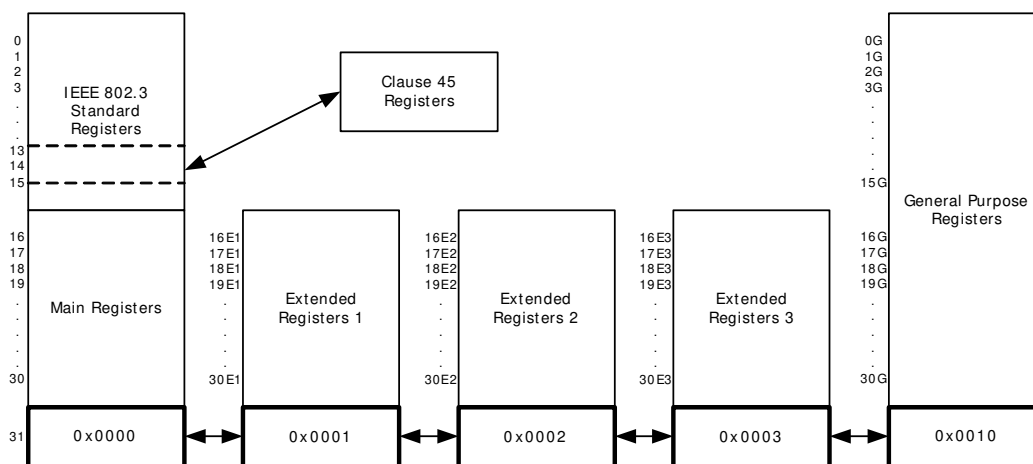

Reserved Registers

For main registers 16–31, extended registers 16E1–30E1, 16E2–30E2, 16E3–30E3, and general purpose registers 0G–30G, any bits marked as Reserved should be processed as read-only and their states as undefined.

Reserved Bits

In writing to registers with reserved bits, use a read-modify-then-write technique, where the entire register is read but only the intended bits to be changed are modified. Reserved bits cannot be changed and their read state cannot be considered static or unchanging.

3.1 Register and Bit Conventions

Registers are referred to by their address and bit number in decimal notation. A range of bits is indicated with a colon. For example, a reference to address 26, bits 15 through 14 is shown as 26.15:14.

A register with an E and a number attached (example 27E1) means it is a register contained within extended register page number 1. A register with a G attached (example 13G) means it is a GPIO page register.

Bit numbering follows the IEEE standard with bit 15 being the most significant bit and bit 0 being the least significant bit.

3.2 IEEE 802.3 and Main Registers

In the VSC8514 device, the page space of the standard registers consists of the IEEE 802.3 standard registers and the Microsemi standard registers. The following table lists the names of the registers associated with the addresses as specified by IEEE 802.3.

Table 11 • IEEE 802.3 Registers

Address	Name
0	Mode Control
1	Mode Status
2	PHY Identifier 1
3	PHY Identifier 2
4	Autonegotiation Advertisement
5	Autonegotiation Link Partner Ability
6	Autonegotiation Expansion
7	Autonegotiation Next-Page Transmit
8	Autonegotiation Link Partner Next-Page Receive
9	1000BASE-T Control
10	1000BASE-T Status
11–12	Reserved
13	Clause 45 Access Registers from IEEE 802.3 Table 22-6 and 22.24.3.11-12 and Annex 22D
14	Clause 45 Access Registers from IEEE 802.3 Table 22-6 and 22.24.3.11-12 and Annex 22D
15	1000BASE-T Status Extension 1

The following table lists the names of the registers in the main page space of the device. These registers are accessible only when register address 31 is set to 0x0000.

Table 12 • Main Registers

Address	Name
16	100BASE-TX status extension
17	1000BASE-T status extension 2
18	Bypass control
19	Error Counter 1
20	Error Counter 2
21	Error Counter 3
22	Extended control and status
23	Extended PHY control 1
24	Extended PHY control 2
25	Interrupt mask
26	Interrupt status
27	Reserved
28	Auxiliary control and status
29	LED mode select
30	LED behavior
31	Extended register page access

3.2.1 Mode Control

The device register at memory address 0 controls several aspects of VSC8514 functionality. The following table shows the available bit settings in this register and what they control.

Table 13 • Mode Control, Address 0 (0x00)

Bit	Name	Access	Description	Default
15	Software reset	R/W	Self-clearing. Restores all serial management interface (SMI) registers to default state, except for sticky and super-sticky bits. 1: Reset asserted. 0: Reset de-asserted. Wait [X] after setting this bit to initiate another SMI register access.	0
14	Loopback	R/W	1: Loopback enabled. 0: Loopback disabled. When loop back is enabled, the device functions at the current speed setting and with the current duplex mode setting (bits 6, 8, and 13 of this register).	0
13	Forced speed selection LSB	R/W	Least significant bit. MSB is bit 6. 00: 10 Mbps. 01: 100 Mbps. 10: 1000 Mbps. 11: Reserved.	0

Table 13 • Mode Control, Address 0 (0x00) (continued)

Bit	Name	Access	Description	Default
12	Autonegotiation enable	R/W	1: Autonegotiation enabled. 0: Autonegotiation disabled.	1
11	Power-down	R/W	1: Power-down enabled.	0
10	Isolate	R/W	1: Disable MAC interface outputs and ignore MAC interface inputs.	0
9	Restart autonegotiation	R/W	Self-clearing bit. 1: Restart autonegotiation on media interface.	0
8	Duplex	R/W	1: Full-duplex. 0: Half-duplex.	0
7	Collision test enable	R/W	1: Collision test enabled.	0
6	Forced speed selection MSB	R/W	Most significant bit. LSB is bit 13. ⁽¹⁾ 00: 10 Mbps. 01: 100 Mbps. 10: 1000 Mbps. 11: Reserved.	10
5	Reserved	RO	Reserved	0
4:0	Reserved		Reserved.	00000

1. Before selecting the 1000 Mbps forced speed mode, manually configure the PHY as master or slave by setting bit 11 in register 9 (1000BASE-T Control). Each time the link drops, the PHY needs to be powered down manually to enable it to link up again using the master/slave setting specified in register 9.11.

3.2.2 Mode Status

The register at address 1 in the device main registers space allows you to read the currently enabled mode setting. The following table shows possible readouts of this register.

Table 14 • Mode Status, Address 1 (0x01)

Bit	Name	Access	Description	Default
15	100BASE-T4 capability	RO	1: 100BASE-T4 capable.	0
14	100BASE-TX FDX capability	RO	1: 100BASE-TX FDX capable.	1
13	100BASE-TX HDX capability	RO	1: 100BASE-TX HDX capable.	1
12	10BASE-T FDX capability	RO	1: 10BASE-T FDX capable.	1
11	10BASE-T HDX capability	RO	1: 10BASE-T HDX capable.	1
10	100BASE-T2 FDX capability	RO	1: 100BASE-T2 FDX capable.	0
9	100BASE-T2 HDX capability	RO	1: 100BASE-T2 HDX capable.	0
8	Extended status enable	RO	1: Extended status information present in register 15.	1
7	Reserved	RO	Reserved.	1
6	Preamble suppression capability	RO	1: MF preamble can be suppressed. 0: MF required.	1
5	Autonegotiation complete	RO	1: Autonegotiation complete.	0

Table 14 • Mode Status, Address 1 (0x01) (continued)

Bit	Name	Access	Description	Default
4	Remote fault	RO	Latches high. 1: Far-end fault detected.	0
3	Autonegotiation capability	RO	1: Autonegotiation capable.	1
2	Link status	RO	Latches low. 1: Link is up.	0
1	Jabber detect	RO	Latches high. 1: Jabber condition detected.	0
0	Extended capability	RO	1: Extended register capable.	1

3.2.3 Device Identification

All 16 bits in both register 2 and register 3 in the VSC8514 device are used to provide information associated with aspects of the device identification. The following tables list the expected readouts.

Table 15 • Identifier 1, Address 2 (0x02)

Bit	Name	Access	Description	Default
15:0	Organizationally unique identifier (OUI)	RO	OUI most significant bits (3:18)	0x0007

Table 16 • Identifier 2, Address 3 (0x03)

Bit	Name	Access	Description	Default
15:10	OUI	RO	OUI least significant bits (19:24)	000001
9:4	Microsemi model number	RO	VSC8514 (0x27)	100111
3:0	Device revision number	RO	Revision A	0000

3.2.4 Autonegotiation Advertisement

The bits in address 4 in the main registers space control the VSC8514 ability to notify other devices of the status of its autonegotiation feature. The following table shows the available settings and readouts.

Table 17 • Device Autonegotiation Advertisement, Address 4 (0x04)

Bit	Name	Access	Description	Default
15	Next page transmission request	R/W	1: Request enabled	0
14	Reserved	RO	Reserved	0
13	Transmit remote fault	R/W	1: Enabled	0
12	Reserved	R/W	Reserved	0
11	Advertise asymmetric pause	R/W	1: Advertises asymmetric pause	0
10	Advertise symmetric pause	R/W	1: Advertises symmetric pause	0
9	Advertise100BASE-T4	R/W	1: Advertises 100BASE-T4	0
8	Advertise100BASE-TX FDX	R/W	1: Advertise 100BASE-TX FDX	1
7	Advertise100BASE-TX HDX	R/W	1: Advertises 100BASE-TX HDX	1
6	Advertise10BASE-T FDX	R/W	1: Advertises 10BASE-T FDX	1

Table 17 • Device Autonegotiation Advertisement, Address 4 (0x04) (continued)

Bit	Name	Access	Description	Default
5	Advertise10BASE-T HDX	R/W	1: Advertises 10BASE-T HDX	1
4:0	Advertise selector	R/W		00001

3.2.5 Link Partner Autonegotiation Capability

The bits in main register 5 can be used to determine if the Cat5 link partner (LP) used with the VSC8514 device is compatible with the autonegotiation functionality.

Table 18 • Autonegotiation Link Partner Ability, Address 5 (0x05)

Bit	Name	Access	Description	Default
15	LP next page transmission request	RO	1: Requested	0
14	LP acknowledge	RO	1: Acknowledge	0
13	LP remote fault	RO	1: Remote fault	0
12	Reserved	RO	Reserved	0
11	LP advertise asymmetric pause	RO	1: Capable of asymmetric pause	0
10	LP advertise symmetric pause	RO	1: Capable of symmetric pause	0
9	LP advertise 100BASE-T4	RO	1: Capable of 100BASE-T4	0
8	LP advertise 100BASE-TX FDX	RO	1: Capable of 100BASE-TX FDX	0
7	LP advertise 100BASE-TX HDX	RO	1: Capable of 100BASE-TX HDX	0
6	LP advertise 10BASE-T FDX	RO	1: Capable of 10BASE-T FDX	0
5	LP advertise 10BASE-T HDX	RO	1: Capable of 10BASE-T HDX	0
4:0	LP advertise selector	RO		00000

3.2.6 Autonegotiation Expansion

The bits in main register 6 work together with those in register 5 to indicate the status of the LP autonegotiation functioning. The following table shows the available settings and readouts.

Table 19 • Autonegotiation Expansion, Address 6 (0x06)

Bit	Name	Access	Description	Default
15:5	Reserved	RO	Reserved.	All zeros
4	Parallel detection fault	RO	This bit latches high. 1: Parallel detection fault.	0
3	LP next page capable	RO	1: LP is next page capable.	0
2	Local PHY next page capable	RO	1: Local PHY is next page capable.	1
1	Page received	RO	This bit latches low. 1: New page is received.	0
0	LP is autonegotiation capable	RO	1: LP is capable of autonegotiation.	0

3.2.7 Transmit Autonegotiation Next Page

The settings in register 7 in the main registers space provide information about the number of pages in an autonegotiation sequence. The following table shows the settings available.

Table 20 • Autonegotiation Next Page Transmit, Address 7 (0x07)

Bit	Name	Access	Description	Default
15	Next page	R/W	1: More pages follow	0
14	Reserved	RO	Reserved	0
13	Message page	R/W	1: Message page 0: Unformatted page	1
12	Acknowledge 2	R/W	1: Complies with request 0: Cannot comply with request	0
11	Toggle	RO	1: Previous transmitted LCW = 0 0: Previous transmitted LCW = 1	0
10:0	Message/unformatted code	R/W		0000000001

3.2.8 Autonegotiation Link Partner Next Page Receive

The bits in register 8 of the main register space work together with register 7 to determine certain aspects of the LP autonegotiation. The following table shows the possible readouts.

Table 21 • Autonegotiation LP Next Page Receive, Address 8 (0x08)

Bit	Name	Access	Description	Default
15	LP next page	RO	1: More pages follow	0
14	Acknowledge	RO	1: LP acknowledge	0
13	LP message page	RO	1: Message page 0: Unformatted page	0
12	LP acknowledge 2	RO	1: LP complies with request	0
11	LP toggle	RO	1: Previous transmitted LCW = 0 0: Previous transmitted LCW = 1	0
10:0	LP message/unformatted code	RO		All zeros

3.2.9 1000BASE-T Control

The VSC8514 device's 1000BASE-T functionality is controlled by the bits in register 9 of the main register space. The following table shows the settings and readouts available.

Table 22 • 1000BASE-T Control, Address 9 (0x09)

Bit	Name	Access	Description	Default
15:13	Transmitter test mode	R/W	000: Normal 001: Mode 1: Transmit waveform test 010: Mode 2: Transmit jitter test as master 011: Mode 3: Transmit jitter test as slave 100: Mode 4: Transmitter distortion test 101–111: Reserved	000

Table 22 • 1000BASE-T Control, Address 9 (0x09) (continued)

Bit	Name	Access	Description	Default
12	Master/slave manual configuration	R/W	1: Master/slave manual configuration enabled	0
11	Master/slave value	R/W	This register is only valid when bit 9.12 is set to 1. 1: Configure PHY as master during negotiation 0: Configure PHY as slave during negotiation	0
10	Port type	R/W	1: Multi-port device 0: Single-port device	1
9	1000BASE-T FDX capability	R/W	1: PHY is 1000BASE-T FDX capable	1
8	1000BASE-T HDX capability	R/W	1: PHY is 1000BASE-T HDX capable	1
7:0	Reserved	R/W	Reserved	0x00

Note Transmitter test mode (bits 15:13) operates in the manner described in IEEE 802.3 section 40.6.1.1.2. When using any of the transmitter test modes, the automatic media sense feature must be disabled. For more information, see "Extended PHY Control Set 2" on page 3-39.

3.2.10 1000BASE-T Status

The bits in register 10 of the main register space can be read to obtain the status of the 1000BASE-T communications enabled in the device. The following table shows the readouts.

Table 23 • 1000BASE-T Status, Address 10 (0x0A)

Bit	Name	Access	Description	Default
15	Master/slave configuration fault	RO	This bit latches high. 1: Master/slave configuration fault detected 0: No master/slave configuration fault detected	0
14	Master/slave configuration resolution	RO	1: Local PHY configuration resolved to master 0: Local PHY configuration resolved to slave	1
13	Local receiver status	RO	1: Local receiver is operating normally	0
12	Remote receiver status	RO	1: Remote receiver OK	0
11	LP 1000BASE-T FDX capability	RO	1: LP 1000BASE-T FDX capable	0
10	LP 1000BASE-T HDX capability	RO	1: LP 1000BASE-T HDX capable	0
9:8	Reserved	RO	Reserved	00
7:0	Idle error count	RO	Self-clearing register	0x00

3.2.11 MMD Access Control Register

The bits in register 13 of the main register space are a window to the EEE registers as defined in IEEE 802.3az Clause 45.

Table 24 • MMD EEE Access, Address 13 (0x0D)

Bit	Name	Access	Description
15:14	Function	R/W	00: Address 01: Data, no post increment 10: Data, post increment for read and write 11: Data, post increment for write only
13:5	Reserved	R/W	Reserved
4:0	DVAD	R/W	Device address as defined in IEEE 802.3az table 45–1

3.2.12 MMD Address or Data Register

The bits in register 14 of the main register space are a window to the EEE registers as defined in IEEE 802.3az Clause 45.

Table 25 • MMD Address or Data Register, Address 14 (0x0E)

Bit	Name	Access	Description
15:0	Register Address/Data	R/W	When register 13.15:14 = 2'b00, address of register of the device that is specified by 13.4:0. Otherwise, the data to be written to or read from the register.

3.2.13 1000BASE-T Status Extension 1

Register 15 provides additional information about the operation of the device 1000BASE-T communications. The following table shows the readouts available.

Table 26 • 1000BASE-T Status Extension 1, Address 15 (0x0F)

Bit	Name	Access	Description	Default
15:14	Reserved	RO	Reserved	0
13	1000BASE-T FDX capability	RO	1: PHY is 1000BASE-T FDX capable	1
12	1000BASE-T HDX capability	RO	1: PHY is 1000BASE-T HDX capable	1
11:0	Reserved	RO	Reserved	0x000

3.2.14 100BASE-TX Status Extension

Register 16 in the main registers page space of the VSC8514 device provides additional information about the status of the device's 100BASE-TX operation.

Table 27 • 100BASE-TX Status Extension, Address 16 (0x10)

Bit	Name	Access	Description	Default
15	100BASE-TX Descrambler	RO	1: Descrambler locked	0
14	100BASE-TX lock error	RO	Self-clearing bit. 1: Lock error detected	0

Table 27 • 100BASE-TX Status Extension, Address 16 (0x10) (continued)

Bit	Name	Access	Description	Default
13	100BASE-TX disconnect state	RO	Self-clearing bit. 1: PHY 100BASE-TX link disconnect detected	0
12	100BASE-TX current link status	RO	1: PHY 100BASE-TX link active	0
11	100BASE-TX receive error	RO	Self-clearing bit. 1: Receive error detected	0
10	100BASE-TX transmit error	RO	Self-clearing bit. 1: Transmit error detected	0
9	100BASE-TX SSD error	RO	Self-clearing bit. 1: Start-of-stream delimiter error detected	0
8	100BASE-TX ESD error	RO	Self-clearing bit. 1: End-of-stream delimiter error detected	0
7:0	Reserved	RO	Reserved	

3.2.15 1000BASE-T Status Extension 2

The second status extension register is at address 17 in the device main registers space. It provides information about another set of parameters associated with 1000BASE-T communications. For information about the first status extension register, see [Table 26 on page 3-34](#).

Table 28 • 1000BASE-T Status Extension 2, Address 17 (0x11)

Bit	Name	Access	Description	Default
15	1000BASE-T descrambler	RO	1: Descrambler locked.	0
14	1000BASE-T lock error	RO	Self-clearing bit. 1: Lock error detected	0
13	1000BASE-T disconnect state	RO	Self-clearing bit. 1: PHY 1000BASE-T link disconnect detected	0
12	1000BASE-T current link status	RO	1: PHY 1000BASE-T link active	0
11	1000BASE-T receive error	RO	Self-clearing bit. 1: Receive error detected	0
10	1000BASE-T transmit error	RO	Self-clearing bit. 1: Transmit error detected	0
9	1000BASE-T SSD error	RO	Self-clearing bit. 1: Start-of-stream delimiter error detected	0
8	1000BASE-T ESD error	RO	Self-clearing bit. 1: End-of-stream delimiter error detected	0
7	1000BASE-T carrier extension error	RO	Self-clearing bit. 1: Carrier extension error detected	0

Table 28 • 1000BASE-T Status Extension 2, Address 17 (0x11) (continued)

Bit	Name	Access	Description	Default
6	Non-compliant BCM5400 detected	RO	1: Non-compliant BCM5400 link partner detected	0
5	MDI crossover error	RO	1: MDI crossover error was detected	0
4:0	Reserved	RO	Reserved	

3.2.16 Bypass Control

The bits in this register control aspects of functionality in effect when the device is disabled for the purpose of traffic bypass. The following table shows the settings available.

Table 29 • Bypass Control, Address 18 (0x12)

Bit	Name	Access	Description	Default
15	Transmit disable	R/W	1: PHY transmitter disabled	0
14	4B5B encoder/decoder	R/W	1: Bypass 4B/5B encoder/decoder	0
13	Scrambler	R/W	1: Bypass scrambler	0
12	Descrambler	R/W	1: Bypass descrambler	0
11	PCS receive	R/W	1: Bypass PCS receiver	0
10	PCS transmit	R/W	1: Bypass PCS transmit	0
9	LFI timer	R/W	1: Bypass Link Fail Inhibit (LFI) timer	0
8	Reserved	RO	Reserved	
7	HP Auto-MDIX at forced 10/100	R/W	Sticky bit. 1: Disable HP Auto-MDIX at forced 10/100 speeds	1
6	Non-compliant BCM5400 detect disable	R/W	Sticky bit. 1: Disable non-compliant BCM5400 detection	0
5	Disable pair swap correction (HP Auto-MDIX when autonegotiation enabled)	R/W	Sticky bit. 1: Disable the automatic pair swap correction	0
4	Disable polarity correction	R/W	Sticky bit. 1: Disable polarity inversion correction on each subchannel	0
3	Parallel detect control	R/W	Sticky bit. 1: Do not ignore advertised ability 0: Ignore advertised ability	1
2	Pulse shaping filter	R/W	1: Disable pulse shaping filter	0
1	Disable automatic 1000BASE-T next page exchange	R/W	Sticky bit. 1: Disable automatic 1000BASE T next page exchanges	0
0	Reserved	RO	Reserved	

Note If bit 18.1 is set to 1 in this register, automatic exchange of next pages is disabled, and control is returned to the user through the SMI after the base page is exchanged. The user then must send the

correct sequence of next pages to the link partner, determine the common capabilities, and force the device into the correct configuration following the successful exchange of pages.

3.2.17 Error Counter 1

The bits in register 19 provide an error counter. The following table shows the settings available.

Table 30 • Extended Control and Status, Address 19 (0x13)

Bit	Name	Access	Description	Default
15:8	Reserved	RO	Reserved.	
7:0	100/1000BASE-TX receive error counter	RO	8-bit counter that saturates when it reaches 255. These bits are self-clearing when read.	0x00

3.2.18 Error Counter 2

The bits in register 20 provide an error counter. The following table shows the settings available.

Table 31 • Extended Control and Status, Address 20 (0x14)

Bit	Name	Access	Description	Default
15:8	Reserved	RO	Reserved.	
7:0	100/1000BASE-TX false carrier counter	RO	8-bit counter that saturates when it reaches 255. These bits are self-clearing when read.	0x00

3.2.19 Error Counter 3

The bits in register 21 provide an error counter. The following table shows the settings available.

Table 32 • Extended Control and Status, Address 21 (0x15)

Bit	Name	Access	Description	Default
15:8	Reserved	RO	Reserved.	
7:0	Copper media link disconnect counter	RO	8-bit counter that saturates when it reaches 255. These bits are self-clearing when read.	0x00

3.2.20 Extended Control and Status

The bits in register 22 provide additional device control and readouts. The following table shows the settings available.

Table 33 • Extended Control and Status, Address 22 (0x16)

Bit	Name	Access	Description	Default
15	Force 10BASE-T link high	R/W	Sticky bit. 1: Bypass link integrity test 0: Enable link integrity test	0
14	Jabber detect disable	R/W	Sticky bit. 1: Disable jabber detect	0
13	Disable 10BASE-T echo	R/W	Sticky bit. 1: Disable 10BASE-T echo	1

Table 33 • Extended Control and Status, Address 22 (0x16) (continued)

Bit	Name	Access	Description	Default
12	Disable SQE mode	R/W	Sticky bit. 1: Disable SQE mode	1
11:10	10BASE-T squelch control	R/W	Sticky bit. 00: Normal squelch 01: Low squelch 10: High squelch 11: Reserved	00
9	Sticky reset enable	R/W	Super-sticky bit. 1: Enabled	1
8	EOF Error	RO	This bit is self-clearing. 1: EOF error detected	0
7	10BASE-T disconnect state	RO	This bit is self-clearing. 1: 10BASE-T link disconnect detected	0
6	10BASE-T link status	RO	1: 10BASE-T link active	0
5:1	Reserved	RO	Reserved	
0	SMI broadcast write	R/W	Sticky bit. 1: Enabled	0

The following information applies to the extended control and status bits:

- When bit 22.15 is set, the link integrity state machine is bypassed and the PHY is forced into a link pass status.
- When bits 22.11:10 are set to 00, the squelch threshold levels are based on the IEEE standard for 10BASE-T. When set to 01, the squelch level is decreased, which can improve the bit error rate performance on long loops. When set to 10, the squelch level is increased and can improve the bit error rate in high-noise environments.
- When bit 22.9 is set, all sticky register bits retain their values during a software reset. Clearing this bit causes all sticky register bits to change to their default values upon software reset. Super-sticky bits retain their values upon software reset regardless of the setting of bit 22.9.
- When bit 22.0 is set, if a write to any PHY register (registers 0–31, including extended registers), the same write is broadcast to all PHYs. For example, if bit 22.0 is set to 1 and a write to PHY0 is executed (register 0 is set to 0x1040), all PHYs' register 0s are set to 0x1040. Disabling this bit restores normal PHY write operation. Reads are still possible when this bit is set, but the value that is read corresponds only to the particular PHY being addressed.

3.2.21 Extended PHY Control Set 1

The following table shows the settings available.

Table 34 • Extended PHY Control 1, Address 23 (0x17)

Bit	Name	Access	Description	Default
15:11	Reserved	R/W	Reserved	0
10:8	Media operating mode	R/W	Super-sticky bits 000: Cat5 copper only	000
7:4	Reserved	RO	Reserved	
3	Far-end loopback mode	R/W	1: Enabled	0

Table 34 • Extended PHY Control 1, Address 23 (0x17) (continued)

Bit	Name	Access	Description	Default
2:0	Reserved	RO	Reserved	

Note After configuring bits 11:8 of the extended PHY control register set 1, a software reset (register 0, bit 15) must be written to change the device operating mode. On read, these bits only indicate the actual operating mode and not the pending operating mode setting before a software reset has taken place.

3.2.22 Extended PHY Control Set 2

The second set of extended controls is located in register 24 in the main register space for the device. The following table shows the settings and readouts available.

Table 35 • Extended PHY Control 2, Address 24 (0x18)

Bit	Name	Access	Description	Default
15:13	100BASE-TX edge rate control	R/W	Sticky bit. 011: +5 edge rate (slowest) 010: +4 edge rate 001: +3 edge rate 000: +2 edge rate 111: +1 edge rate 110: Default edge rate 101: –1 edge rate 100: –2 edge rate (fastest)	001
12	PICMG 2.16 reduced power mode	R/W	Sticky bit. 1: Enabled	0
11:6	Reserved	RO	Reserved	
5:4	Jumbo packet mode	R/W	Sticky bit. 00: Normal IEEE 1.5 kB packet length 01: 9 kB jumbo packet length (12 kB with 60 ppm or better reference clock) 10: 12 kB jumbo packet length (16 kB with 70 ppm or better reference clock) 11: Reserved	00
3:1	Reserved	RO	Reserved	
0	1000BASE-T connector loopback	R/W	1: Enabled	0

Note When bits 5:4 are set to jumbo packet mode, the default maximum packet values are based on 100 ppm driven reference clock to the device. Controlling the ppm offset between the MAC and the PHY as specified in the bit description results in a higher jumbo packet length.

3.2.23 Interrupt Mask

These bits control the device interrupt mask. The following table shows the settings available.

Table 36 • Interrupt Mask, Address 25 (0x19)

Bit	Name	Access	Description	Default
15	MDINT interrupt status enable	R/W	Sticky bit. 1: Enabled.	0
14	Speed state change mask	R/W	Sticky bit. 1: Enabled.	0
13	Link state change mask	R/W	Sticky bit. 1: Enabled.	0
12	FDX state change mask	R/W	Sticky bit. 1: Enabled.	0
11	Autonegotiation error mask	R/W	Sticky bit. 1: Enabled.	0
10	Autonegotiation complete mask	R/W	Sticky bit. 1: Enabled.	0
9	Inline-powered device (PoE) detect mask	R/W	Sticky bit. 1: Enabled.	0
8	Symbol error interrupt mask	R/W	Sticky bit. 1: Enabled.	0
7	Reserved	RO	Reserved.	0
6	TX FIFO over/underflow interrupt mask	R/W	Sticky bit. 1: Enabled.	0
5	RX FIFO over/underflow interrupt mask	R/W	Sticky bit. 1: Enabled.	0
4	Reserved	RO	Reserved.	0
3	False carrier interrupt mask	R/W	Sticky bit. 1: Enabled.	0
2	Link speed downshift detect mask	R/W	Sticky bit. 1: Enabled.	0
1	Master/Slave resolution error mask	R/W	Sticky bit. 1: Enabled.	0
0	RX_ER interrupt mask	R/W	Sticky bit. 1: Enabled.	0

Note When bit 25.15 is set, the MDINT pin is enabled. When enabled, the state of this pin reflects the state of bit 26.15. Clearing this bit only inhibits the MDINT pin from being asserted. Also, before enabling this bit, read register 26 to clear any previously inactive interrupts pending that will cause bit 25.15 to be set.

3.2.24 Interrupt Status

The status of interrupts already written to the device is available for reading from register 26 in the main registers space. The following table shows the expected readouts.

Table 37 • Interrupt Status, Address 26 (0x1A)

Bit	Name	Access	Description	Default
15	Interrupt status	RO	Self-clearing bit. 1: Interrupt pending.	0
14	Speed state change status	RO	Self-clearing bit. 1: Interrupt pending.	0
13	Link state change status	RO	Self-clearing bit. 1: Interrupt pending.	0
12	FDX state change status	RO	Self-clearing bit. 1: Interrupt pending.	0
11	Autonegotiation error status	RO	Self-clearing bit. 1: Interrupt pending.	0
10	Autonegotiation complete status	RO	Self-clearing bit. 1: Interrupt pending.	0
9	Inline-powered device detect status	RO	Self-clearing bit. 1: Interrupt pending.	0
8	Symbol error status	RO	Self-clearing bit. 1: Interrupt pending.	0
7	Reserved	RO	Reserved.	0

Table 37 • Interrupt Status, Address 26 (0x1A) (continued)

Bit	Name	Access	Description	Default
6	TX FIFO over/underflow detect status	RO	Self-clearing bit. 1: Interrupt pending.	0
5	RX FIFO over/underflow detect status	RO	Self-clearing bit. 1: Interrupt pending.	0
4	Reserved	RO	Reserved.	0
3	False carrier interrupt status	RO	Self-clearing bit. 1: Interrupt pending.	0
2	Link speed downshift detect status	RO	Self-clearing bit. 1: Interrupt pending.	0
1	Master/Slave resolution error status	RO	Self-clearing bit. 1: Interrupt pending.	0
0	RX_ER interrupt status	RO	Self-clearing bit. 1: Interrupt pending.	0

The following information applies to the interrupt status bits:

- All set bits in this register are cleared after being read (self-clearing). If bit 26.15 is set, the cause of the interrupt can be read by reading bits 26.14:0.
- For bits 26.14 and 26.12, bit 0.12 must be set for this interrupt to assert.
- For bit 26.2, bits 4.8:5 must be set for this interrupt to assert.
- For bit 26.0, this interrupt will not occur when RX_ER is used for carrier-extension decoding of a link partner's data transmission.

3.2.25 Device Auxiliary Control and Status

Register 28 provides control and status information for several device functions not controlled or monitored by other device registers. The following table shows the settings available and the expected readouts.

Table 38 • Auxiliary Control and Status, Address 28 (0x1C)

Bit	Name	Access	Description	Default
15	Autonegotiation complete	RO	Duplicate of bit 1.5	0
14	Autonegotiation disabled	RO	Inverted duplicate of bit 0.12	0
13	HP Auto-MDIX crossover indication	RO	1: HP Auto-MDIX crossover performed internally	0
12	CD pair swap	RO	1: CD pairs are swapped	0
11	A polarity inversion	RO	1: Polarity swap on pair A	0
10	B polarity inversion	RO	1: Polarity swap on pair B	0
9	C polarity inversion	RO	1: Polarity swap on pair C	0
8	D polarity inversion	RO	1: Polarity swap on pair D	0
7	ActiPHY link status time-out control [1]	R/W	Sticky bit. Bits 7 and 2 are part of the ActiPHY Link Status time-out control. Bit 7 is the MSB. 00: 2.3 second 01: 3.3 seconds 10: 4.3 seconds 11: 5.3 seconds	0

Table 38 • Auxiliary Control and Status, Address 28 (0x1C) (continued)

Bit	Name	Access	Description	Default
6	ActiPHY mode enable	R/W	Sticky bit. 1: Enabled	0
5	FDX status	RO	1: Full-duplex 0: Half-duplex	00
4:3	Speed status	RO	00: Speed is 10BASE-T 01: Speed is 100BASE-TX or 100BASE-FX 10: Speed is 1000BASE-T or 1000BASE-X 11: Reserved	0
2	ActiPHY link status time-out control [0]	R/W	Sticky bit. Bits 7 and 2 are part of the ActiPHY Link Status time-out control. Bit 7 is the MSB. 00: 2.3 second 01: 3.3 seconds 10: 4.3 seconds 11: 5.3 seconds	1
1:0	Media mode status	RO	00: No media selected 01: Copper media selected 10: Reserved 11: Reserved	00

3.2.26 LED Mode Select

The device LED outputs are controlled using the bits in register 29 of the main register space. The following table shows the information needed to access the functionality of each of the outputs. For more information about LED modes, see [Table 4 on page 2-14](#).

Table 39 • LED Mode Select, Address 29 (0x1D)

Bit	Name	Access	Description	Default
15:12	LED3 mode select	R/W	Sticky bit. Select from LED modes 0–15.	1000
11:8	LED2 mode select	R/W	Sticky bit. Select from LED modes 0–15.	0000
7:4	LED1 mode select	R/W	Sticky bit. Select from LED modes 0–15.	0010
3:0	LED0 mode select	R/W	Sticky bit. Select from LED modes 0–15.	0001

3.2.27 LED Behavior

The bits in register 30 control and enable you to read the status of the pulse or blink rate of the device LEDs. The following table shows the settings you can write to the register or read from the register.

Table 40 • LED Behavior, Address 30 (0x1E)

Bit	Name	Access	Description	Default
15:13	Reserved	RO	Reserved	

Table 40 • LED Behavior, Address 30 (0x1E) (continued)

Bit	Name	Access	Description	Default
12	LED pulsing enable	R/W	Sticky bit 0: Normal operation 1: LEDs pulse with a 5 kHz, programmable duty cycle when active	0
11:10	LED blink/pulse-stretch rate	R/W	Sticky bit 00: 2.5 Hz blink rate/400 ms pulse-stretch 01: 5 Hz blink rate/200 ms pulse-stretch 10: 10 Hz blink rate/100 ms pulse-stretch 11: 20 Hz blink rate/50 ms pulse-stretch The blink rate selection for PHY0 globally sets the rate used for all LED pins on all PHY ports	01
9	Reserved	RO	Reserved	
8	LED3 pulse-stretch/blink select	R/W	Sticky bit 1: Pulse-stretch 0: Blink	0
7	LED2 pulse-stretch/blink select	R/W	Sticky bit 1: Pulse-stretch 0: Blink	0
6	LED1 pulse-stretch/blink select	R/W	Sticky bit 1: Pulse-stretch 0: Blink	0
5	LED0 pulse-stretch/blink select	R/W	Sticky bit 1: Pulse-stretch 0: Blink	0
4	Reserved	RO	Reserved	
3	LED3 combine feature disable	R/W	Sticky bit 0: Combine enabled (link/activity, duplex/collision) 1: Disable combination (link only, duplex only)	0
2	LED2 combine feature disable	R/W	Sticky bit 0: Combine enabled (link/activity, duplex/collision) 1: Disable combination (link only, duplex only)	0
1	LED1 combine feature disable	R/W	Sticky bit 0: Combine enabled (link/activity, duplex/collision) 1: Disable combination (link only, duplex only)	0
0	LED0 combine feature disable	R/W	Sticky bit 0: Combine enabled (link/activity, duplex/collision) 1: Disable combination (link only, duplex only)	0

Note Bits 30.11:10 are active only in port 0 and affect the behavior of LEDs for all the ports.

3.2.28 Extended Page Access

To provide functionality beyond the IEEE 802.3-specified registers and main device registers, the VSC8514 device includes an extended set of registers that provide an additional 15 register spaces.

The register at address 31 controls the access to the extended registers for the VSC8514 device. Accessing the GPIO page register space is similar to accessing the extended page registers. The following table shows the settings available.

Table 41 • Extended/GPIO Register Page Access, Address 31 (0x1F)

Bit	Name	Access	Description	Default
15:0	Extended/GPIO page register access	R/W	<p>0x0000: Register 16–30 accesses main register space. Writing 0x0000 to register 31 restores the main register access.</p> <p>0x0001: Registers 16–30 access extended register space 1</p> <p>0x0002: Registers 16–30 access extended register space 2</p> <p>0x0003: Registers 16–30 access extended register space 3</p> <p>0x0010: Registers 0–30 access GPIO register space</p>	0x0000

3.3 Extended Page 1 Registers

To access the extended page 1 registers (16E1–30E1), enable extended register access by writing 0x0001 to register 31. Writing 0x0000 to register 31 restores the main register access.

When extended page 1 register access is enabled, reads and writes to registers 16–30 affect the extended registers 16E1–30E1 instead of those same registers in the IEEE-specified register space. Registers 0–15 are not affected by the state of the extended page register access.

Table 42 • Extended Registers Page 1 Space

Address	Name
16E1	Reserved
17E1	Reserved
18E1	Cu Media CRC good counter
19E1	Extended mode control
20E1	Extended PHY control 3 (ActiPHY)
21E1–22E1	Reserved
23E1	Extended PHY control 4 (PoE and CRC error counter)
27E1–28E1	Reserved
29E1	Ethernet packet generator (EPG) 1
30E1	EPG 2

3.3.1 Cu Media CRC Good Counter

Register 18E1 makes it possible to read the contents of the CRC good counter for packets that are received on the Cu media interface; the number of CRC routines that have executed successfully. The following table shows the expected readouts.

Table 43 • Cu Media CRC Good Counter, Address 18E1 (0x12)

Bit	Name	Access	Description	Default
15	Packet since last read	RO	Self-clearing bit. 1: Packet received since last read.	0
14	Reserved	RO	Reserved.	
13:0	Cu Media CRC good counter contents	RO	Self-clearing bit. Counter containing the number of packets with valid CRCs modulo 10,000; this counter does not saturate and will roll over to zero on the next good packet received after 9,999.	0x000

3.3.2 Extended Mode Control

Register 19E1 controls the LED and other chip modes. The following table shows the settings available.

Table 44 • Extended Mode Control, Address 19E1 (0x13)

Bit	Name	Access	Description	Default
15:12	Reserved	RO	Reserved	0
11	LED Reset Blink Suppress	R/W	1: Blink LEDs after COMA_MODE is de-asserted 0: Suppress LED blink after COMA_MODE is de-asserted	0
10:4	Reserved	RO	Reserved	0
3:2	Force MDI crossover	R/W	00: Normal HP Auto-MDIX operation 01: Reserved 10: Copper media forced to MDI 11: Copper media forced MDI-X	00
1:0	Reserved	RO	Reserved	

3.3.3 ActiPHY Control

Register 20E1 controls the device ActiPHY sleep timer, its wake-up timer, and its link speed downshifting feature. The following table shows the settings available.

Table 45 • Extended PHY Control 3, Address 20E1 (0x14)

Bit	Name	Access	Description	Default
15	Disable carrier extension	R/W	1: Disable carrier extension in SGMII/1000BASE-T copper links	1

Table 45 • Extended PHY Control 3, Address 20E1 (0x14) (continued)

Bit	Name	Access	Description	Default
14:13	ActiPHY sleep timer	R/W	Sticky bit. 00: 1 second 01: 2 seconds 10: 3 seconds 11: 4 seconds	01
12:11	ActiPHY wake-up timer	R/W	Sticky bit. 00: 160 ms 01: 400 ms 10: 800 ms 11: 2 seconds	00
10	Reserved	RO	Reserved	
9	PHY address reversal	R/W	Reverse PHY address Enabling causes physical PHY 0 to have address of 3, PHY 1 address of 2, PHY 2 address of 1, and PHY 3 address of 0. Changing this bit to 1 should initially be done from PHY 0 and changing to 0 from PHY3 1: Enabled 0: Disabled	0
8	Reserved	RO	Valid only on PHY0	
7:6	Media mode status	RO	00: No media selected 01: Copper media selected 10: Reserved 11: Reserved	00
5	Enable 10BASE-T no preamble mode	R/W	Sticky bit. 1: 10BASE-T will assert RX_DV indication when data is presented to the receiver even without a preamble preceding it	0
4	Enable link speed autoshift feature	R/W	Sticky bit. 1: Enable auto link speed downshift from 1000BASE-T	0
3:2	Link speed auto downshift control	R/W	Sticky bit. 00: Downshift after 2 failed 1000BASE-T autonegotiation attempts 01: Downshift after 3 failed 1000BASE-T autonegotiation attempts 10: Downshift after 4 failed 1000BASE-T autonegotiation attempts 11: Downshift after 5 failed 1000BASE-T autonegotiation attempts	01
1	Link speed auto downshift status	RO	0: No downshift 1: Downshift is required or has occurred	0
0	Reserved	RO	Reserved	

3.3.4 PoE and Miscellaneous Functionality

The register at address 23E1 controls various aspects of inline-powering and the CRC error counter in the VSC8514 device.

Table 46 • Extended PHY Control 4, Address 23E1 (0x17)

Bit	Name	Access	Description	Default
15:11	PHY address	RO	PHY address; latched on reset	
10	Inline-powered device detection	R/W	Sticky bit. 1: Enabled	0
9:8	Inline-powered device detection status	RO	Only valid when bit 10 is set. 00: Searching for devices 01: Device found; requires inline-power 10: Device found; does not require inline-power 11: Reserved	00
7:0	Cu Media CRC error counter	RO	Self-clearing bit	

RC error counter for packets received on the Cu media interface. The value saturates at 0xFF and subsequently clears when read and restarts count 0x00.

3.3.5 Ethernet Packet Generator Control 1

The EPG control register provides access to and control of various aspects of the EPG testing feature. There are two separate EPG control registers. The following table shows the settings available in the first register.

Table 47 • EPG Control Register 1, Address 29E1 (0x1D)

Bit	Name	Access	Description	Default
15	EPG enable	R/W	1: Enable EPG	0
14	EPG run or stop	R/W	1: Run EPG	0
13	Transmission duration	R/W	1: Continuous (sends in 10,000-packet increments) 0: Send 30,000,000 packets and stop	0
12:11	Packet length	R/W	00: 125 bytes 01: 64 bytes 10: 1518 bytes 11: 10,000 bytes (jumbo packet)	0
10	Interpacket gap	R/W	1: 8,192 ns 0: 96 ns	0
9:6	Destination address	R/W	Lowest nibble of the 6-byte destination address	0001
5:2	Source address	R/W	Lowest nibble of the 6-byte destination address	0000
1	Payload type	R/W	1: Randomly generated payload pattern 0: Fixed based on payload pattern	0

Table 47 • EPG Control Register 1, Address 29E1 (0x1D) (continued)

Bit	Name	Access	Description	Default
0	Bad frame check sequence (FCS) generation	R/W	1: Generate packets with bad FCS 0: Generate packets with good FCS	0

The following information applies to the EPG control number 1:

- Do not run the EPG when the VSC8514 is device connected to a live network.
- bit 29E1.13 (continuous EPG mode control): When enabled, this mode causes the device to send continuous packets. When disabled, the device continues to send packets only until it reaches the next 10,000-packet increment mark. It then ceases to send packets.
- The 6-byte destination address in bits 9:6 is assigned one of 16 addresses in the range of 0xFF FF FF FF F0 through 0xFF FF FF FF FF.
- The 6-byte source address in bits 5:2 is assigned one of 16 addresses in the range of 0xFF FF FF FF F0 through 0xFF FF FF FF FF.
- If any of bits 13:0 are changed while the EPG is running (bit 14 is set to 1), bit 14 must be cleared and then set back to 1 for the change to take effect and to restart the EPG.

3.3.6 Ethernet Packet Generator Control 2

Register 30E1 consists of the second set of bits that provide access to and control over the various aspects of the EPG testing feature. The following table shows the settings available.

Table 48 • EPG Control Register 2, Address 30E1 (0x1E)

Bit	Name	Access	Description	Default
15:0	EPG packet payload	R/W	Data pattern repeated in the payload of packets generated by the EPG	0x00

Note If any of bits 15:0 in this register are changed while the EPG is running (bit 14 of register 29E1 is set to 1), that bit (29E1.14) must first be cleared and then set back to 1 for the change to take effect and to restart the EPG.

3.4 Extended Page 2 Registers

To access the extended page 2 registers (16E2–30E2), enable extended register access by writing 0x0002 to register 31. For more information, see [Table 41 on page 3-44](#).

When extended page 2 register access is enabled, reads and writes to registers 16–30 affect the extended registers 16E2–30E2 instead of those same registers in the IEEE-specified register space. Registers 0–15 are not affected by the state of the extended page register access.

Writing 0x0000 to register 31 restores the main register access.

The following table lists the addresses and register names in the extended register page 2 space. These registers are accessible only when the device register 31 is set to 0x0002.

Table 49 • Extended Registers Page 2 Space

Address	Name
16E2	Cu PMD Transmit Control
17E2	EEE Control
18E2-30E2	Reserved

3.4.1 Cu PMD Transmit Control

The register at address 16E2 consists of the bits that provide control over the amplitude settings for the transmit side Cu PMD interface. These bits provide the ability to make small adjustments in the signal amplitude to compensate for minor variations in the magnetics from different vendors. Extreme caution must be exercised when changing these settings from the default values as they have a direct impact on the signal quality. Changing these settings also affects the linearity and harmonic distortion of the transmitted signals. For help with changing these values, contact your Microsemi representative.

Table 50 • Cu PMD Transmit Control, Address 16E2 (0x10)

Bit	Name	Access	Description	Default
15:12	1000BASE-T signal amplitude trim ⁽¹⁾	R/W	1000BASE-T signal amplitude 1111: -1.7% 1110: -2.6% 1101: -3.5% 1100: -4.4% 1011: -5.3% 1010: -7% 1001: -8.8% 1000: -10.6% 0111: 5.5% 0110: 4.6% 0101: 3.7% 0100: 2.8% 0011: 1.9% 0010: 1% 0001: 0.1% 0000: -0.8%	0000
11:8	100BASE-TX signal amplitude trim ⁽²⁾	R/W	100BASE-TX signal amplitude 1111: -1.7% 1110: -2.6% 1101: -3.5% 1100: -4.4% 1011: -5.3% 1010: -7% 1001: -8.8% 1000: -10.6% 0111: 5.5% 0110: 4.6% 0101: 3.7% 0100: 2.8% 0011: 1.9% 0010: 1% 0001: 0.1% 0000: -0.8%	0010

Table 50 • Cu PMD Transmit Control, Address 16E2 (0x10) (continued)

Bit	Name	Access	Description	Default
7:4	10BASE-T signal amplitude trim ⁽³⁾	R/W	10BASE-T signal amplitude 1111: -7% 1110: -7.9% 1101: -8.8% 1100: -9.7% 1011: -10.6% 1010: -11.5% 1001: -12.4% 1000: -13.3% 0111: 0% 0110: -0.7% 0101: -1.6% 0100: -2.5% 0011: -3.4% 0010: -4.3% 0001: -5.2% 0000: -6.1%	1011
3:0	10BASE-Te signal amplitude trim	R/W	10BASE-Te signal amplitude 1111: -30.45% 1110: -31.1% 1101: -31.75% 1100: -32.4% 1011: -33.05% 1010: -33.7% 1001: -34.35% 1000: -35% 0111: -25.25% 0110: -25.9% 0101: -26.55% 0100: -27.2% 0011: -27.85% 0010: -28.5% 0001: -29.15% 0000: -29.8%	1110

1. Changes to 1000BASE-T amplitude may result in side effects and hide issues due to a questionable board design.
2. Adjust 100BASE-TX to specific magnetics.
3. Amplitude limited by VCC(2.5 V).

3.4.2 EEE Control

The register at address 17E2 consists of the bits that provide additional control over the chip behavior in energy efficient Ethernet (IEEE 802.3az) mode for debug and to allow interoperability with legacy MACs that do not support IEEE 802.3az.

Table 51 • EEE Control, Address 17E2 (0x11)

Bit	Name	Access	Description	Default
15	Enable 10BASE-T _e	R/W	Enable energy efficient (IEEE 802.3az) 10BASE-T _e operating mode.	0
14	Reserved	RO	Reserved.	0
13:10	Invert LED polarity	R/W	Invert polarity of LED[3:0]_[3:0] signals. Default is to drive an active low signal on the LED pins. This also applies to enhanced serial LED mode. For more information, see "Enhanced Serial LED Mode" on page 2-16.	0000
9:6	Reserved	RO	Reserved.	
5	Enable 1000BASE-T force mode	R/W	1: Enable 1000BASE-T force mode to allow PHY to link-up in 1000BASE-T mode without forcing master/slave when register 0, bit 6 and 13 are set to 2'b10.	0
4	Force transmit LPI	R/W	1: Enable the EPG to transmit LPI on the MDI instead of normal idles when receiving normal idles from the MAC. 0: Transmit idles being received from the MAC.	0
3	Inhibit 100BASE-TX transmit EEE LPI	R/W	1: Disable transmission of EEE LPI on transmit path MDI in 100BASE-TX mode when receiving LPI from MAC.	0
2	Inhibit 100BASE-TX receive EEE LPI	R/W	1: Disable transmission of EEE LPI on receive path MAC interface in 100BASE-TX mode when receiving LPI from the MDI.	0
1	Inhibit 1000BASE-T transmit EEE LPI	R/W	1: Disable transmission of EEE LPI on transmit path MDI in 1000BASE-T mode when receiving LPI from MAC.	0
0	Inhibit 1000BASE-T receive EEE LPI	R/W	1: Disable transmission of EEE LPI on receive path MAC interface in 1000BASE-T mode when receiving LPI from the MDI.	0

3.5 Extended Page 3 Registers

To access the extended page 3 registers (16E3–30E3), enable extended register access by writing 0x0003 to register 31. For more information, see [Table 41 on page 3-44](#).

When extended page 3 register access is enabled, reads and writes to registers 16–30 affect the extended registers 16E3–30E3 instead of those same registers in the IEEE-specified register space. Registers 0–15 are not affected by the state of the extended page register access.

Writing 0x0000 to register 31 restores the main register access.

The following table lists the addresses and register names in the extended register page 3 space. These registers are accessible only when the device register 31 is set to 0x0003.

Table 52 • Extended Registers Page 3 Space

Address	Name
16E3	MAC SerDes PCS Control
17E3	MAC SerDes PCS Status
18E3	MAC SerDes Clause 37 Advertised Ability
19E3	MAC SerDes Clause 37 Link Partner Ability
20E3	MAC SerDes Status
21E3–30E3	Reserved

3.5.1 MAC SerDes PCS Control

The register at address 16E3 consists of the bits that provide access to and control over MAC SerDes PCS block. The following table shows the settings available.

Table 53 • MAC SerDes PCS Control, Address 16E3 (0x10)

Bit	Name	Access	Description	Default
15	MAC interface disable	R/W	Sticky bit. 1: 1000BASE-X MAC interface disable when media link down.	0
14	MAC interface restart	R/W	Sticky bit. 1: 1000BASE-X MAC interface restart on media link change.	0
13	MAC interface PD enable	R/W	Sticky bit. 1: MAC interface autonegotiation parallel detect enable.	0
12	MAC interface autonegotiation restart	R/W	Self-clearing bit. 1: Restart MAC interface autonegotiation.	0
11	Force advertised ability	R/W	1: Force 16-bit advertised ability from register 18E3.	0
10:8	SGMII preamble control	R/W	000: No effect on the start of packet. 001: If both the first two nibbles of the 10/100 packet are not 0x5, a byte of 0x55 must be prefixed to the output, otherwise there will be no effect on the start of packet. 010: If both the first two nibbles of the 10/100 packet are not 0x5, a byte of 0x55 must be prefixed to the output. An additional byte of 0x55 must be prefixed to the output if the next two nibbles are also not 0x5. 011–111: Reserved.	001
7	MAC SerDes autonegotiation enable	R/W	1: MAC SerDes ANEG enable.	0
6	SerDes polarity at input of MAC	R/W	1: Invert polarity of signal received at input of MAC.	0

Table 53 • MAC SerDes PCS Control, Address 16E3 (0x10) (continued)

Bit	Name	Access	Description	Default
5	SerDes polarity at output of MAC	R/W	1: Invert polarity of signal at output of MAC.	
4:0	Reserved	RO	Reserved.	

3.5.2 MAC SerDes PCS Status

The register at address 17E3 consists of the bits that provide status from the MAC SerDes PCS block. The following table shows the settings available.

Table 54 • MAC SerDes PCS Status, Address 17E3 (0x11)

Bit	Name	Access	Description
15:12	Reserved	RO	Reserved
11	MAC interface LP autonegotiation restart	RO	1: MAC interface link partner autonegotiation restart request occurred
10	Reserved	RO	Reserved
9:8	MAC remote fault	RO	01, 10, and 11: Remote fault detected from MAC 00: No remote fault detected from MAC
7	Asymmetric pause advertisement	RO	1: Asymmetric pause advertised by MAC
6	Symmetric pause advertisement	RO	1: Symmetric pause advertised by MAC
5	Full duplex advertisement	RO	1: Full duplex advertised by MAC
4	Half duplex advertisement	RO	1: Half duplex advertised by MAC
3	MAC interface LP autonegotiation capable	RO	1: MAC interface link partner autonegotiation capable
2	MAC interface link status	RO	1: MAC interface link status connected
1	MAC interface autonegotiation complete	RO	1: MAC interface autonegotiation complete
0	MAC interface PCS signal detect	RO	1: MAC interface PCS signal detect present

3.5.3 MAC SerDes Clause 37 Advertised Ability

The register at address 18E3 consists of the bits that provide access to and control over MAC SerDes Clause 37 advertised ability. The following table shows the settings available.

Table 55 • MAC SerDes Clause 37 Advertised Ability, Address 18E3 (0x12)

Bit	Name	Access	Description	Default
15:0	MAC SerDes advertised ability	R/W	Current configuration code word being advertised (this register is read/write if 16E3.11 = 1)	0x0000

3.5.4 MAC SerDes Clause 37 Link Partner Ability

The register at address 19E3 consists of the bits that provide status of the MAC SerDes link partner's Clause 37 advertised ability. The following table shows the settings available.

Table 56 • MAC SerDes CI37 LP Ability, Address 19E3 (0x13)

Bit	Name	Access	Description
15:0	MAC SerDes LP ability	RO	Last configuration code word received from link partner

3.5.5 MAC SerDes Status

The register at address 20E3 consists of the bits that provide access to MAC SerDes status. The following table shows the settings available.

Table 57 • MAC SerDes Status, Address 20E3 (0x14)

Bit	Name	Access	Description
15	Reserved	RO	Reserved
14	SerDes signal detect	RO	Self-clearing bit. Sticky bit. 1: SerDes signal detection occurred
13	QSGMII sync status	RO	
12:0	Reserved	RO	Reserved

3.6 General Purpose Registers

Accessing the general purpose register space is similar to accessing the extended page registers. Set register 31 to 0x0010. This sets all 32 registers to the general purpose register space.

To restore main register page access, write 0x0000 to register 31.

The following table lists the addresses and register names in the general purpose register page space. These registers are accessible only when the device register 31 is set to 0x0010. All general purpose register bits are super-sticky. This register space is global in nature to all four PHY's in the VSC8514 device.

Table 58 • General Purpose Registers Page Space

Address	Name
0G–12G	Reserved
13G	LED/GPIO Control
14G	GPIO Control 2
15G	GPIO Input
16G	GPIO Output
17G	GPIO Output Enable
18G	Micro Command
19G	MAC Mode and Fast Link Configuration
20G	Reserved
21G	Reserved
22G	Reserved

Table 58 • General Purpose Registers Page Space (continued)

Address	Name
23G	Recovered Clock 1 Control
24G	Recovered Clock 2 Control
25G	Enhanced LED Control
26G	Reserved
27G	Reserved
28G	Reserved
29G	Global Interrupt Status
30G	Reserved

3.6.1 Reserved General Purpose Address Space

The bits in registers 0G to 12G and 30G of the general purpose register space are reserved.

3.6.2 GPIO Control

The GPIO control bits configure the GPIO[3:0] pins. The following table shows the values that can be written.

Table 59 • GPIO Control, Address 13G (0x0D)

Bit	Name	Access	Description	Default
15:14	GPIO7 control	R/W	00: Reserved 01: Reserved 10: Reserved 11: Controlled by MII registers 15G to 17G	00
13:12	GPIO6 control	R/W	00: Reserved 01: Reserved 10: Reserved 11: Controlled by MII registers 15G to 17G	00
11:10	GPIO5 control	R/W	00: Reserved 01: Reserved 10: Reserved 11: Controlled by MII registers 15G to 17G	00
9:8	GPIO4 control	R/W	00: Reserved 01: Reserved 10: Reserved 11: Controlled by MII registers 15G to 17G	00
7:6	GPIO3 control	R/W	00: Reserved 01: Reserved 10: Reserved 11: Controlled by MII registers 15G to 17G	00

Table 59 • GPIO Control, Address 13G (0x0D) (continued)

Bit	Name	Access	Description	Default
5:4	GPIO2 control	R/W	00: Reserved 01: Reserved 10: Reserved 11: Controlled by MII registers 15G to 17G	00
3:2	GPIO1 control	R/W	00: Reserved 01: Reserved 10: Reserved 11: Controlled by MII registers 15G to 17G	00
1:0	GPIO0 control	R/W	00: Reserved 01: Reserved 10: Reserved 11: Controlled by MII registers 15G to 17G	00

3.6.3 GPIO Control 2

The GPIO control 2 register configures the functionality of the COMA_MODE input pins, and provides control for possible GPIO pin options.

Table 60 • GPIO Control 2, Address 14G (0x0E)

Bit	Name	Access	Description	Default
15:14	GPIO12 control, GPIO13 control, and GPIO14 control	R/W	Control the operation of GPIO12, GPIO13, and GPIO14 pins. 00: Reserved 01: Reserved 10: Reserved 11: GPIO12/GPIO13/GPIO14 - controlled by MII registers 15G to 17G	00
13	COMA_MODE output enable (active low)	R/W	1: COMA_MODE pin is an input. 0: COMA_MODE pin is an output.	1
12	COMA_MODE output data	R/W	Value to output on the COMA_MODE pin when it is configured as an output.	0
11	COMA_MODE input data	RO	Data read from the COMA_MODE pin.	
10	Reserved	R/W	Reserved.	1
9	Tri-state enable for LEDs	R/W	1: Tri-state LED output signals instead of driving them high. this allows the signals to be pulled above VDDIO using an external pull-up resistor. 0: Drive LED bus output signals to high and low values, as appropriate.	0
8	Reserved	RO	Reserved	0

Table 60 • GPIO Control 2, Address 14G (0x0E) (continued)

Bit	Name	Access	Description	Default
7:6	GPIO11 control	R/W	GPIO11 control. 00: Reserved 01: Reserved 10: Reserved 11: Controlled by MII registers 15G to 17G	00
5:4	GPIO10 control	R/W	GPIO10 control. 00: Reserved 01: Reserved 10: Reserved 11: Controlled by MII registers 15G to 17G	00
3:2	GPIO9 control	R/W	GPIO9 control. 00: Reserved 01: Reserved 10: Reserved 11: Controlled by MII registers 15G to 17G	00
1:0	GPIO8 control	R/W	GPIO8 control. 00: Reserved 01: Reserved 10: Reserved 11: Controlled by MII registers 15G to 17G	00

3.6.4 GPIO Input

The input register contains information about the input to the device GPIO pins. Read from this register to access the data on the device GPIO pins. The following table shows the readout you can expect.

Table 61 • GPIO Input, Address 15G (0x0F)

Bit	Name	Access	Description	Default
15	Reserved	RO	Reserved	
14	GPIO14	R/W	GPIO14 input	0
13	GPIO13	R/W	GPIO13 input	0
12	GPIO12	R/W	GPIO12 input	0
11	GPIO11	R/W	GPIO11 input	0
10	GPIO10	R/W	GPIO10 input	0
9	GPIO9	R/W	GPIO9 input	0
8	GPIO8	R/W	GPIO8 input	0
7	GPIO7	R/W	GPIO7 input	0
6	GPIO6	R/W	GPIO6 input	0
5	GPIO5	R/W	GPIO5 input	0
4	GPIO4	R/W	GPIO4 input	0
3	GPIO3	R/W	GPIO3 input	0
2	GPIO2	R/W	GPIO2 input	0

Table 61 • GPIO Input, Address 15G (0x0F) (continued)

Bit	Name	Access	Description	Default
1	GPIO1	R/W	GPIO1 input	0
0	GPIO0	R/W	GPIO0 input	0

3.6.5 GPIO Output

The output register allows you to access and control the output from the device GPIO pins. The following table shows the values you can write.

Table 62 • GPIO Output, Address 16G (0x10)

Bit	Name	Access	Description	Default
15	Reserved	RO	Reserved	
14	GPIO14	R/W	GPIO14 output	0
13	GPIO13	R/W	GPIO13 output	0
12	GPIO12	R/W	GPIO12 output	0
11	GPIO11	R/W	GPIO11 output	0
10	GPIO10	R/W	GPIO10 output	0
9	GPIO9	R/W	GPIO9 output	0
8	GPIO8	R/W	GPIO8 output	0
7	GPIO7	R/W	GPIO7 output	0
6	GPIO6	R/W	GPIO6 output	0
5	GPIO5	R/W	GPIO5 output	0
4	GPIO4	R/W	GPIO4 output	0
3	GPIO3	R/W	GPIO3 output	0
2	GPIO2	R/W	GPIO2 output	0
1	GPIO1	R/W	GPIO1 output	0
0	GPIO0	R/W	GPIO0 output	0

3.6.6 GPIO Pin Configuration

Register 17G in the GPIO register space controls whether a particular GPIO pin functions as an input or an output. The following table shows the settings available.

Table 63 • GPIO Input/Output Configuration, Address 17G (0x11)

Bit	Name	Access	Description	Default
15	Reserved	RO	Reserved	
14	GPIO14	R/W	GPIO14 output enable	0
13	GPIO13	R/W	GPIO13 output enable	0
12	GPIO12	R/W	GPIO12 output enable	0
11	GPIO11	R/W	GPIO11 output enable	0
10	GPIO10	R/W	GPIO10 output enable	0
9	GPIO9	R/W	GPIO9 output enable	0

Table 63 • GPIO Input/Output Configuration, Address 17G (0x11) (continued)

Bit	Name	Access	Description	Default
8	GPIO8	R/W	GPIO8 output enable	0
7	GPIO7	R/W	GPIO7 output enable	0
6	GPIO6	R/W	GPIO6 output enable	0
5	GPIO5	R/W	GPIO5 output enable	0
4	GPIO4	R/W	GPIO4 output enable	0
3	GPIO3	R/W	GPIO3 output enable	0
2	GPIO2	R/W	GPIO2 output enable	0
1	GPIO1	R/W	GPIO1 output enable	0
0	GPIO0	R/W	GPIO0 output	0

3.6.7 Micro Command

Register 18G is a command register. Bit 15 tells the internal processor to execute the command. When bit 15 is cleared the command has completed. Software needs to wait until bit 15 = 0 before proceeding with the next PHY register access. Bit 14 = 1 typically indicates an error condition. Use the following steps to execute the command:

1. Write desired command
2. Check bit 15 (move existing text)
3. Check bit 14 (if set, then error)

Commands may take up to 25 ms to complete before bit 15 changes to 0.

Table 64 • Micro Command Register, Address 18G

Command	Setting
Enable 4 ports MAC QSGMII	0x80E0
QSGMII transmitter control ⁽¹⁾	

1. Contact your Microsemi representative for details.

3.6.8 MAC Configuration

Register 19G in the GPIO register space controls the MAC interface mode. The following table shows the settings available for the GPIO9 pin.

Table 65 • MAC Configuration Register, Address 19G (0x13)

Bit	Name	Access	Description	Default
15:14	MAC configuration	R/W	Select MAC interface mode 00: Reserved 01: QSGMII 10: Reserved 11: Reserved	00
13:4	Reserved	RO	Reserved	
3:0	Reserved	RO	Reserved	0xF

3.6.9 Recovered Clock 1 Control

Register 23G in the extended register space controls the functionality of the recovered clock 1 output signal.

Table 66 • Recovered Clock 1 Control, Address 23G (0x17)

Bit	Name	Access	Description	Default
15	Enable RCVRDCLK1	R/W	1: Enable recovered clock 1 output 0: Disable recovered clock 1 output	0
14:11	Clock source select	R/W	Select bits for source PHY for recovered clock: 0000: PHY0 0001: PHY1 0010: PHY2 0011: PHY3 0100–1111: Reserved	0000
10:8	Clock frequency select	R/W	Select output clock frequency: 000: 25 MHz output clock 001: 125 MHz output clock 010: 31.25 MHz output clock 011–111: Reserved	000
7:6	Reserved	RO	Reserved.	
5:4	Clock squelch level	R/W	Select clock squelch level 00: Automatically squelch clock to low when the link is not up, is unstable, is up in a mode that does not support the generation of a recovered clock (1000BASE-T master or 10BASE-T), or is up in EEE mode (100BASE-TX or 1000BASE-T slave). 01: Same as 00 except that the clock is also generated in 1000BASE-T master and 10BASE-T link-up modes. This mode also generates a recovered clock output in EEE mode during reception of LP_IDLE. 10: Squelch only when the link is not up. 11: Disable clock squelch. Note A clock from the SerDes or Cu PHY will be output on the recovered clock output in this mode when the link is down. When the CLK_SQUELCH_IN pin is set high, it squelches the recovered clocks regardless of bit settings.	
3	Reserved	RO	Reserved.	
2:0	Clock selection for specified PHY	R/W	000: Reserved 001: Copper PHY recovered clock 010: Copper PHY transmitter TCLK 011–111: Reserved	000

3.6.10 Recovered Clock 2 Control

Register 24G in the extended register space controls the functionality of the recovered clock 2 output signal.

Table 67 • Recovered Clock 2 Control, Address 24G (0x18)

Bit	Name	Access	Description	Default
15	Enable RCVRDCLK2	R/W	Enable recovered clock 2 output	0
14:11	Clock source select	R/W	Select bits for source PHY for recovered clock: 0000: PHY0 0001: PHY1 0010: PHY2 0011: PHY3 0100–1111: Reserved	0000
10:8	Clock frequency select	R/W	Select output clock frequency: 000: 25 MHz output clock 001: 125 MHz output clock 010: 31.25 MHz output clock 011–111: Reserved	000
7:6	Reserved	RO	Reserved	
5:4	Clock squelch level	R/W	Select clock squelch level: 00: Automatically squelch clock to low when the link is not up, is unstable, is up in a mode that does not support the generation of a recovered clock (1000BASE-T master or 10BASE-T), or is up in EEE mode (100BASE-TX or 1000BASE-T slave). 01: Same as 00 except that the clock is also generated in 1000BASE-T master and 10BASE-T link-up modes. This mode also generates a recovered clock output in EEE mode during reception of LP_IDLE 10: Squelch only when the link is not up 11: Disable clock squelch. Note A clock from the SerDes or Cu PHY will be output on the recovered clock output in this mode when the link is down. Note A clock from the SerDes or Cu PHY will be output on the recovered clock output in this mode when the link is down. When the CLK_SQUELCH_IN pin is set high, it squelches the recovered clocks regardless of bit settings.	
3	Reserved	RO	Reserved	
2:0	Clock selection for specified PHY	R/W	000: Reserved 001: Copper PHY recovered clock 010–111: Reserved	000

3.6.11 Enhanced LED Control

The following table contains the bits to control advanced functionality of the parallel and serial LED signals.

Table 68 • Enhanced LED Control, Address 25G (0x19)

Bit	Name	Access	Description	Default
15:8	LED pulsing duty cycle control	R/W	Programmable control for LED pulsing duty cycle when bit 30.12 is set to 1. Valid settings are between 0 and 198. A setting of 0 corresponds to a 0.5% duty cycle and 198 corresponds to a 99.5% duty cycle. Intermediate values change the duty cycle in 0.5% increments	00
7	Port 1 enhanced serial LED output enable	R/W	Enable the enhanced serial LED output functionality for port 1 LED pins. 1: Enhanced serial LED outputs 0: Normal function	0
6	Port 0 enhanced serial LED output enable	R/W	Enable the enhanced serial LED output functionality for port 0 LED pins. 1: Enhanced serial LED outputs 0: Normal function	0
5:3	Serial LED frame rate selection	R/W	Select frame rate of serial LED stream 000: 2500 Hz frame rate 001: 1000 Hz frame rate 010: 500 Hz frame rate 011: 250 Hz frame rate 100: 200 Hz frame rate 101: 125 Hz frame rate 110: 40 Hz frame rate 111: Output basic serial LED stream See Table 5 on page 2-15 .	
2:1	Serial LED select	R/W	Select which LEDs from each PHY to enable on the serial stream 00: Enable all four LEDs of each PHY 01: Enable LEDs 2, 1 and 0 of each PHY 10: Enable LEDs 1 and 0 of each PHY 11: Enable LED 0 of each PHY	00
0	LED port swapping	R/W	See " LED Port Swapping " on page 2-17.	

3.6.12 Global Interrupt Status

The following table contains the interrupt status from the various sources to indicate which one caused that last interrupt on the pin.

Table 69 • Global Interrupt Status, Address 29G (0x1D)

Bit	Name	Access	Description
15:4	Reserved	RO	Reserved

Table 69 • Global Interrupt Status, Address 29G (0x1D) (continued)

Bit	Name	Access	Description
3	PHY3 interrupt source ⁽¹⁾	RO	PHY3 interrupt source indication 0: PHY3 caused the interrupt 1: PHY3 did not cause the interrupt
2	PHY2 interrupt source ⁽¹⁾	RO	PHY2 interrupt source indication 0: PHY2 caused the interrupt 1: PHY2 did not cause the interrupt
1	PHY1 interrupt source ⁽¹⁾	RO	PHY1 interrupt source indication 0: PHY1 caused the interrupt 1: PHY1 did not cause the interrupt
0	PHY0 interrupt source ⁽¹⁾	RO	PHY0 interrupt source indication 0: PHY0 caused the interrupt 1: PHY0 did not cause the interrupt

1. This bit is set to 1 when the corresponding PHY's Interrupt Status register 26 (0x1A) is read.

3.7 Clause 45 Registers to Support Energy Efficient Ethernet and 802.3bf

This section describes the Clause 45 registers that are required to support energy efficient Ethernet. Access to these registers is through the IEEE standard registers 13 and 14 (MMD access control and MMD data or address registers) as described in section 4.2.11 and 4.2.12.

The following table lists the addresses and register names in the Clause 45 register page space. When the link is down, 0 is the value returned for the x.180x addresses.

Table 70 • Clause 45 Registers Page Space

Address	Name
1.1801	Tx maximum delay through PHY
1.1803	Tx minimum delay through PHY
1.1805	Rx maximum delay through PHY
1.1807	Rx minimum delay through PHY
3.1	PCS status 1
3.20	EEE capability
3.22	EEE wake error counter
4.1801	Tx maximum delay through xMII (QSGMII, including FIFO variations)
4.1803	Tx minimum delay through xMII (QSGMII, including FIFO variations)
4.1805	Rx maximum delay through xMII (QSGMII, including FIFO variations)
4.1807	Rx minimum delay through xMII (QSGMII, including FIFO variations)
7.60	EEE advertisement
7.61	EEE link partner advertisement

3.7.1 PCS Status 1

The bits in the PCS Status 1 register provide a status of the EEE operation from the PCS for the link that is currently active.

Table 71 • PCS Status 1, Address 3.1

Bit	Name	Access	Description
15:12	Reserved	RO	Reserved
11	Tx LPI received	RO/LH	1: Tx PCS has received LPI 0: LPI not received
10	Rx LPI received	RO/LH	1: Rx PCS has received LPI 0: LPI not received
9	Tx LPI indication	RO	1: Tx PCS is currently receiving LPI 0: PCS is not currently receiving LPI
8	Rx LPI indication	RO	1: Rx PCS is currently receiving LPI 0: PCS is not currently receiving LPI
7:3	Reserved	RO	Reserved
2	PCS receive link status	RO	1: PCS receive link up 0: PCS receive link down
1:0	Reserved	RO	Reserved

3.7.2 EEE Capability

This register is used to indicate the capability of the PCS to support EEE functions for each PHY type. The following table shows the bit assignments for the EEE capability register.

Table 72 • EEE Capability, Address 3.20

Bit	Name	Access	Description
15:3	Reserved	RO	Reserved
2	1000BASE-T EEE	RO	1: EEE is supported for 1000BASE-T 0: EEE is not supported for 1000BASE-T
1	100BASE-TX EEE	RO	1: EEE is supported for 100BASE-TX 0: EEE is not supported for 100BASE-TX
0	Reserved	RO	Reserved

3.7.3 EEE Wake Error Counter

This register is used by PHY types that support EEE to count wake time faults where the PHY fails to complete its normal wake sequence within the time required for the specific PHY type. The definition of the fault event to be counted is defined for each PHY and can occur during a refresh or a wakeup as defined by the PHY. This 16-bit counter is reset to all zeros when the EEE wake error counter is read or when the PHY undergoes hardware or software reset.

Table 73 • EEE Wake Error Counter, Address 3.22

Bit	Name	Access	Description
15:0	Wake error counter	RO	Count of wake time faults for a PHY

3.7.4 EEE Advertisement

This register defines the EEE advertisement that is sent in the unformatted next page following a EEE technology message code. The following table shows the bit assignments for the EEE advertisement register.

Table 74 • EEE Advertisement, Address 7.60

Bit	Name	Access	Description	Default
15:3	Reserved	RO	Reserved	
2	1000BASE-T EEE	R/W	1: Advertise that the 1000BASE-T has EEE capability 0: Do not advertise that the 1000BASE-T has EEE capability	0
1	100BASE-TX EEE	R/W	1: Advertise that the 100BASE-TX has EEE capability 0: Do not advertise that the 100BASE-TX has EEE capability	0
0	Reserved	RO	Reserved	

3.7.5 EEE Link Partner Advertisement

All the bits in the EEE LP Advertisement register are read only. A write to the EEE LP advertisement register has no effect. When the AN process has been completed, this register will reflect the contents of the link partner's EEE advertisement register. The following table shows the bit assignments for the EEE advertisement register.

Table 75 • EEE Advertisement, Address 7.61

Bit	Name	Access	Description
15:3	Reserved	RO	Reserved
2	1000BASE-T EEE	RO	1: Link partner is advertising EEE capability for 1000BASE-T 0: Link partner is not advertising EEE capability for 1000BASE-T
1	100BASE-TX EEE	RO	1: Link partner is advertising EEE capability for 100BASE-TX 0: Link partner is not advertising EEE capability for 100BASE-TX
0	Reserved	RO	Reserved

The following table shows the bit assignments for the 802.3bf registers. When the link is down, 0 is the value returned. cl45reg1_1801 would be device address of 1 and register address of 1801.

Table 76 • 802.3bf Registers

Register	Name	Function
1.1801	cl45reg1_1801_val[15:0]	Tx maximum delay through PHY (PMA/PMD/PCS)
1.1803	cl45reg1_1803_val[15:0]	Tx minimum delay through PHY (PMA/PMD/PCS)
1.1805	cl45reg1_1805_val[15:0]	Rx maximum delay through PHY (PMA/PMD/PCS)
1.1807	cl45reg1_1807_val[15:0]	Rx minimum delay through PHY (PMA/PMD/PCS)
4.1801	cl45reg4_1801_val[15:0]	Tx maximum delay through xMII (QSGMII, including FIFO variations)

Table 76 • 802.3bf Registers (continued)

Register	Name	Function
4.1803	cl45reg4_1803_val[15:0]	Tx minimum delay through xMII (QSGMII, including FIFO variations)
4.1805	cl45reg4_1805_val[15:0]	Rx maximum delay through xMII (QSGMII, including FIFO variations)
4.1807	cl45reg4_1807_val[15:0]	Rx minimum delay through xMII (QSGMII, including FIFO variations)

4 Electrical Specifications

This section provides the DC characteristics, AC characteristics, recommended operating conditions, and stress ratings for the VSC8514 device.

4.1 DC Characteristics

This section contains the DC specifications for the VSC8514 device.

4.1.1 VDD25 and VDDMDIO (2.5 V)

The following table shows the DC specifications for the pins referenced to V_{VDD25} and $V_{VDDMDIO}$ when it is set to 2.5 V. The specifications listed in the following table are valid only when $V_{VDD1} = 1.0$ V, $V_{VDD1A} = 1.0$ V and $V_{VDD25A} = 2.5$ V.

Table 77 • VDD25 and VDDMDIO

Parameter	Symbol	Minimum	Maximum	Unit	Condition
Output high voltage, LVTTTL	V_{OH_TTL}	2.0	2.8	V	$I_{OH} = -1$ mA
Output high voltage, open drain	V_{OH_OD}	2.0	2.8	V	$I_{OH} = -100$ μ A
Output low voltage	V_{OL}	-0.3	0.4	V	$I_{OL} = 4$ mA
Input high voltage	V_{IH}	1.85	3.3	V	Except SMI pins
Input high voltage	V_{IH}	1.88	3.3	V	SMI pins
Input low voltage	V_{IL}	-0.3	0.7	V	
Input leakage current	I_{I_LEAK}	-32	32	μ A	Internal resistor included (except GPIO, LED, and COMA_MODE)
Input leakage current	I_{I_LEAK}	-76	32	μ A	Internal resistor included (GPIO, LED, and COMA_MODE)
Output leakage current	I_{O_LEAK}	-32	32	μ A	Internal resistor included (except GPIO, LED, and COMA_MODE)
Output leakage current	I_{O_LEAK}	-76	32	μ A	Internal resistor included (GPIO, LED, and COMA_MODE)

4.1.2 VDDMDIO (1.2 V)

The following table shows the DC specifications for the pins referenced to $V_{VDDMDIO}$ when it is set to 1.2 V. The specifications listed in the following table are valid only when $V_{VDD1} = 1.0$ V, $V_{VDD1A} = 1.0$ V, $V_{VDD25} = 2.5$ V, $V_{VDD25A} = 2.5$ V, and $V_{VDDMDIO} = 1.2$ V.

Table 78 • VDDMDIO

Parameter	Symbol	Minimum	Maximum	Unit	Condition
Output high voltage, open drain	V_{OH}	1.0	1.5	V	$I_{OH} = -100$ μ A
Output low voltage, open drain	V_{OL}	-0.3	0.25	V	$I_{OL} = 4$ mA
Input high voltage	V_{IH}	0.9	1.5	V	
Input low voltage	V_{IL}	-0.3	0.36	V	
Input leakage current	I_{LEAK}	-32	32	μ A	Internal resistor included
Output leakage current	I_{OLEAK}	-32	32	μ A	Internal resistor included

4.1.3 LED and GPIO

The following table shows the DC specifications for the LED and GPIO pins.

Table 79 • LED and GPIO

Parameter	Symbol	Minimum	Maximum	Unit	Condition
Output high voltage for LED pins, LVTTTL	V_{OH}	1.7	2.8	V	$V_{VDD25} = 2.5$ V $I_{OH} = -24$ mA
Output low voltage for LED pins, LVTTTL	V_{OL}	-0.3	0.6	V	$V_{VDD25} = 2.5$ V $I_{OL} = 24$ mA
Output high voltage for GPIO pins, LVTTTL	V_{OH}	1.7	2.8	V	$V_{VDD25} = 2.5$ V $I_{OH} = -12$ mA
Output low voltage for GPIO pins, LVTTTL	V_{OL}	-0.3	0.6	V	$V_{VDD25} = 2.5$ V $I_{OL} = 12$ mA

4.1.4 Internal Pull-Up or Pull-Down Resistors

Internal pull-up or pull-down resistors are specified in the following table. For more information about signals with internal pull-up or pull-down resistors, see "Pins by Function" on page 5-81.

All internal pull-up resistors are connected to their respective I/O supply.

Table 80 • Internal Pull-Up or Pull-Down Resistors

Parameter	Symbol	Minimum	Typical	Maximum	Unit
Internal pull-up resistor (GPIO, LED, and COMA_MODE)	R_{PU1}	33	53	90	k Ω
Internal pull-up resistor, all others	R_{PU2}	96	120	144	k Ω
Internal pull-down resistor	R_{PD}	96	120	144	k Ω

4.1.5 Reference Clock

The following table shows the DC specifications for a differential reference clock input signal.

Table 81 • Reference Clock

Parameter	Symbol	Minimum	Typical	Maximum	Unit
Input voltage range	V_{IP}, V_{IN}	-25		1260	mV
Input differential voltage	V_{ID}	150 ⁽¹⁾		1000	mV
Input common-mode voltage	V_{ICM}	0		1200 ⁽²⁾	mV
Differential input impedance	R_I		100		Ω

1. To meet jitter specifications, the minimum input differential voltage must be 400 mV.
2. The maximum common-mode voltage is provided without a differential signal. The common-mode voltage is only limited by the maximum and minimum input voltage range and the input signal's differential amplitude.

4.1.6 Enhanced SerDes Interface (QSGMII)

All DC specifications for the enhanced SerDes interface are compliant with QSGMII Specification Revision 1.3 and meet or exceed the requirements in the standard. They are also compliant with OIF-CEI-02.0 requirements where applicable.

The following table shows the DC specifications for the enhanced SerDes driver.

Table 82 • QSGMII Driver

Parameter	Symbol	Minimum	Maximum	Unit	Condition
Output differential peak voltage	$ V_{ODp} $	400	750	mV	$V_{DD_VS} = 1.0\text{ V}$ $R_L = 100\ \Omega \pm 1\%$ maximum drive
Differential resistance	R_O	80	120	Ω	$V_C = 1.0\text{ V}$
Output current, drivers shorted to ground	$ I_{OSA} $, $ I_{OSB} $		40	mA	

The following table lists the DC specifications for the enhanced SerDes receiver.

Table 83 • QSGMII Receiver

Parameter	Symbol	Minimum	Typical	Maximum	Unit	Condition
Input voltage range, V_{IA} or V_{IB} ⁽¹⁾	V_I	-25		1200	mV	
Input differential peak-to-peak voltage	$ V_{ID} $	100		1600	mV	
Common-mode voltage	R_{CMV}		Internal CMV		mV	AC coupled operation ⁽²⁾
Common-mode voltage	R_{CMV}	$V_{DD1A} - 100$	V_{DD1A}	$V_{DD1A} + 100$	mV	DC coupled operation, load type 2 ⁽²⁾
Receiver differential input impedance	R_I	80	100	120	Ω	

1. QSGMII DC input sensitivity is less than 400 mV.

2. Mode for common mode termination is specified by setting of configuration register. Input amplitude in DC coupled mode must not exceed maximum input voltage range.

4.1.7 Current Consumption

The following tables show the typical current consumption values for the 4-port QSGMII mode. Add significant margin above the values for sizing power supplies.

Table 84 • Current Consumption

Mode	Typical				Maximum				Unit
	1 V Digital	1 V Analog	2.5 V Digital	2.5 V Analog	1 V Digital	1 V Analog	2.5 V Digital	2.5 V Analog	
Power down	75	155	10	20	225	200	10	25	mA
1000BASE-T idle	340	185	10	445	585	245	10	560	mA
1000BASE-T traffic	355	185	10	445	605	245	10	560	mA
100BASE-TX idle	150	165	10	290	325	210	10	335	mA
100BASE-TX traffic	150	165	10	290	325	210	10	335	mA
10BASE-T idle	95	162	10	110	230	200	10	125	mA
10BASE-T traffic	95	162	10	215	240	200	10	235	mA
1000BASE-T EEE LPI	135	160	10	202	385	200	10	225	mA
100BASE-TX EEE LPI	102	160	10	205	350	200	10	225	mA

4.2 AC Characteristics

This section provides the AC specifications for the VSC8514 device.

4.2.1 Reference Clock

The use of a differential reference clock source is required to meet QSGMII jitter generation requirements.

The following table shows the AC specifications for a differential reference clock input. Performance is guaranteed for 125 MHz and 156.25 MHz differential clocks only.

Table 85 • Reference Clock for QSGMII 125 MHz Differential Clock

Parameter	Symbol	Minimum	Typical	Maximum	Unit	Condition
Reference clock frequency, REFCLK_SEL[1:0] = 00	f		125.00		MHz	±100 ppm Jitter < 1 ps RMS
Reference clock frequency, REFCLK_SEL[1:0] = 10	f		156.25		MHz	±100 ppm
Duty cycle	DC	40	50	60	%	
Rise time and fall time	t_R, t_F			1.5	ns	20% to 80% threshold

Table 85 • Reference Clock for QSGMII 125 MHz Differential Clock (continued)

Parameter	Symbol	Minimum	Typical	Maximum	Unit	Condition
RefClk input RMS jitter requirement, bandwidth between 12 kHz and 500 kHz ⁽¹⁾				20	ps	To meet jitter generation of 1G output data per IEEE 802.3z
RefClk input RMS jitter requirement, bandwidth between 500 kHz and 15 MHz ⁽¹⁾				4	ps	Meets jitter generation of 1G output data per IEEE 802.3z
RefClk input RMS jitter requirement, bandwidth between 15 MHz and 40 MHz ⁽¹⁾				20	ps	Meets jitter generation of 1G output data per IEEE 802.3z
RefClk input RMS jitter requirement, bandwidth between 40 MHz and 80 MHz ⁽¹⁾				100	ps	Meets jitter generation of 1G output data per IEEE 802.3z
Jitter gain from RefClk to SerDes output, bandwidth between 0.1 MHz and 0.1 MHz				0.3	dB	
Jitter gain from RefClk to SerDes output, bandwidth between 0.1 MHz and 7 MHz			1	3	dB	
Jitter gain from RefClk to SerDes output, bandwidth above 7 MHz		1–20 × log (f/7 MHz)		3–20 × log (f/7 MHz)	dB	

1. Maximum RMS sinusoidal jitter allowed at the RefClk input when swept through the given bandwidth.

4.2.2 Recovered Clock

This section provides the AC characteristics for the recovered clock output signals. The following illustration shows the test circuit for the recovered clock output signals.

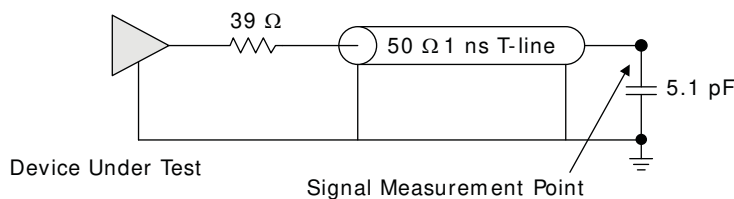
Figure 17 • Test Circuit for Recovered Clock Output Signals

The following table shows the AC specifications for the RCVRDCLK1 and RCVRDCLK2 outputs.

Table 86 • Recovered Clock AC Characteristics

Parameter	Symbol	Minimum	Typical	Maximum	Unit	Condition
Recovered clock frequency	f		125.00		MHz	
Recovered clock frequency	f		31.25		MHz	
Recovered clock frequency	f		25.00		MHz	
Recovered clock cycle time	t_{RCYC}		8.0		ns	
Recovered clock cycle time	t_{RCYC}		32.0		ns	
Recovered clock cycle time	t_{RCYC}		40.0		ns	
Duty cycle	DC	45	50	55	%	
Clock rise time and fall time	t_R, t_F			1.0	ns	20% to 80%
Peak-to-peak jitter, copper media interface, 1000BASE-T	JPP_{CLK_Cu}			400	ps	10k samples

4.2.3 Enhanced SerDes Interface

All AC specifications for the enhanced SerDes interface are compliant with QSGMII Specification Revision 1.3 and meet or exceed the requirements in the standard. They are also compliant with the OIF-CEI-02.0 requirements where applicable.

The transmit and receive eye specifications relate to the eye diagrams shown in the following illustration, with the compliance load as defined in the test circuit.

Figure 18 • QSGMII Transient Parameters

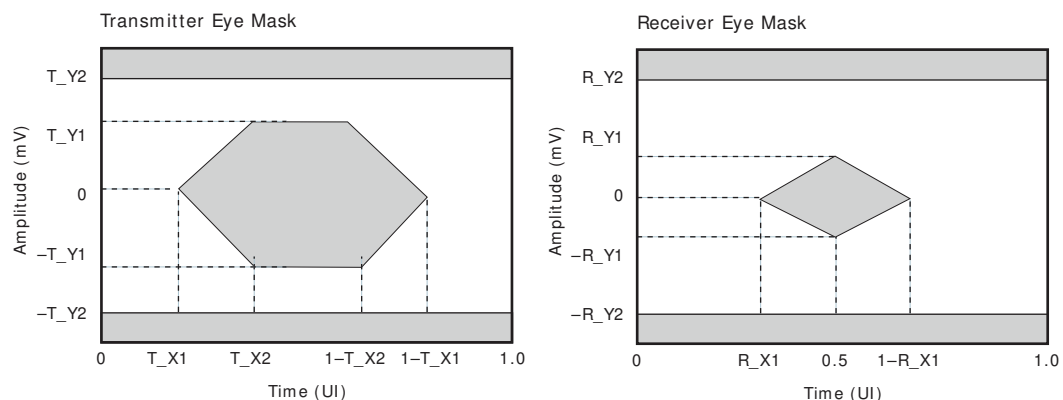

The following table provides the AC specifications for the enhanced SerDes outputs in QSGMII mode.

Table 87 • QSGMII Transmitter

Parameter	Symbol	Minimum	Typical	Maximum	Unit	Condition
Signaling speed	T_{BAUD}	5.00 – 100 ppm	5.00	5.00 + 100 ppm	Gbps	
Differential output return loss	$RLO_{\text{SDD}22}$			–8	dB	100 MHz to 2.5 GHz $R_L = 100 \Omega \pm 1\%$
Differential output return loss	$RLO_{\text{SDD}22}$			$-8 + 16.6 \log(f/2.5 \text{ GHz})$	dB	2.5 GHz to 5 GHz $R_L = 100 \Omega \pm 1\%$
Common-mode output return loss	$RLO_{\text{SCC}22}$			–6	dB	100 MHz to 2.5 GHz $R_L = 25 \Omega \pm 1\%$
Rise time and fall time	t_R, t_F	30		130	ps	20% to 80% of register programmable slew rate
Random jitter	RJ			0.15	UI_{P-P}	
Deterministic jitter	DJ			0.15	UI_{P-P}	
Duty cycle distortion (part of DJ)	DCD			0.05	UI_{P-P}	
Total jitter	TJ			0.30	UI_{P-P}	
Eye mask X1	X1			0.15	UI_{P-P}	Near-end
Eye mask X2	X2			0.40	UI_{P-P}	Near-end
Eye mask Y1	Y1	200			mV	Near-end
Eye mask Y2	Y2			450	mV	Near-end

The following table lists the AC specifications for the enhanced SerDes inputs in QSGMII mode.

Table 88 • QSGMII Receiver

Parameter	Symbol	Minimum	Typical	Maximum	Unit	Condition
Signaling speed	T_{BAUD}	5.00 – 100 ppm	5.00	5.00 + 100 ppm	Gbps	
Differential input return loss	$RLI_{\text{SDD}11}$			–8	dB	100 MHz to 2.5 GHz
Differential input return loss	$RLI_{\text{SDD}11}$			$-8 + 16.6 \log(f/2.5 \text{ GHz})$	dB	2.5 GHz to 5 GHz
Common-mode input return loss	$RLI_{\text{SCC}11}$			–6	dB	100 MHz to 2.5 GHz
Sinusoidal jitter, maximum	SJ_{MAX}			5	UI_{P-P}	Low sinusoidal jitter frequencies below (baud/1667)
Sinusoidal jitter, high frequency	SJ_{HF}			0.05	UI_{P-P}	
Deterministic jitter (uncorrelated bounded high-probability jitter)	UBHPJ			0.15	UI_{P-P}	
Data dependant jitter (correlated bounded high-probability jitter)	CBHPJ			0.30	UI_{P-P}	
Total jitter	TJ			0.60	UI_{P-P}	Sinusoidal jitter excluded

Table 88 • QSGMII Receiver

Parameter	Symbol	Minimum	Typical	Maximum	Unit	Condition
Eye mask X1	R_X1			0.30	UI _{P,P}	
Eye mask Y1	R_Y1	50			mV	
Eye mask Y2	R_Y2			450	mV	

4.2.4 Basic Serial LEDs

This section contains the AC specifications for the basic serial LEDs.

Table 89 • Basic Serial LEDs

Parameter	Symbol	Typical	Unit
LED_CLK cycle time	t_{CYC}	1024	ns
Pause between LED port sequences	t_{PAUSE_PORT}	3072	ns
Pause between LED bit sequences	t_{PAUSE_BIT}	25.541632	ms
LED_CLK to LED_DATA	t_{CO}	1	ns

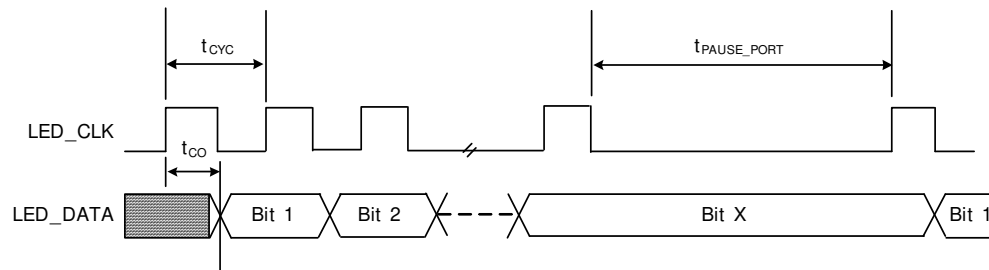
Figure 19 • Basic Serial LED Timing

4.2.5 Enhanced Serial LEDs

This section contains the AC specifications for the enhanced serial LEDs. The duty cycle of the LED_PULSE signal is programmable and can be varied between 0.5% and 99.5%.

Table 90 • Enhanced Serial LEDs

Parameter	Symbol	Minimum	Typical	Maximum	Unit
LED_CLK cycle time	t_{CYC}		256		ns
Pause between LED_DATA bit sequences	t_{PAUSE}	0.396		24.996	μ s
LED_CLK to LED_DATA	t_{CO}		127		ns
LED_CLK to LED_LD	t_{CL}		256		ns
LED_LD pulse width	t_{LW}		128		ns
LED_PULSE cycle time	t_{PULSE}	199		201	μ s

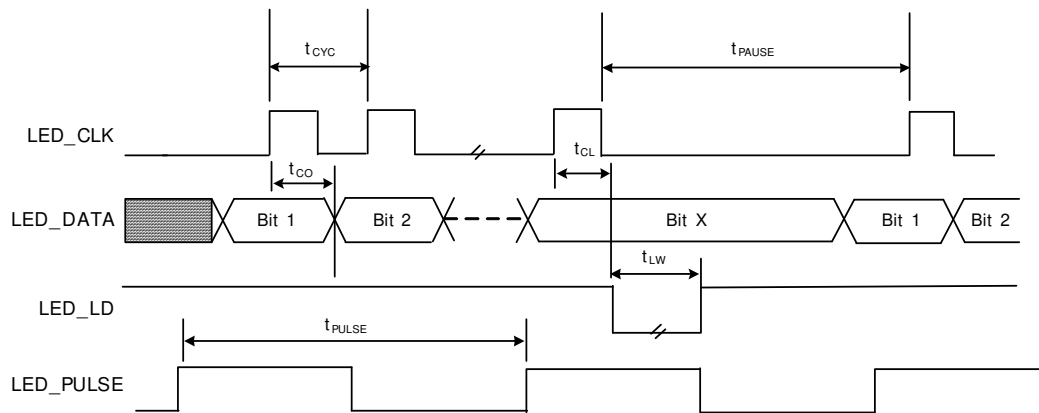
Figure 20 • Enhanced Serial LED Timing

4.2.6 JTAG Interface

This section provides the AC specifications for the JTAG interface. The specifications meet or exceed the requirements of IEEE 1149.1-2001. The JTAG receive signal requirements are requested at the pin of the device. The JTAG_TRST signal is asynchronous to the clock, and does not have a setup or hold time requirement.

Table 91 • JTAG Interface

Parameter	Symbol	Minimum	Maximum	Unit	Condition
TCK frequency	f		10	MHz	
TCK cycle time	t_c	100		ns	
TCK high time	$t_{W(CH)}$	40		ns	
TCK low time	$t_{W(CL)}$	40		ns	
Setup time to TCK rising	t_{SU}	10		ns	
Hold time from TCK rising	t_H	10		ns	
TDO valid after TCK falling	$t_{V(C)}$		28	ns	$C_L = 10$ pF
TDO hold time from TCK falling	$t_{H(TDO)}$	0		ns	$C_L = 0$ pF
TDO disable time ⁽¹⁾	t_{DIS}		30	ns	See Figure 22 on page 4-76.
TRST time low	$t_{W(TL)}$	30		ns	

1. The pin begins to float when a 300 mV change from the actual V_{OH}/V_{OL} level occurs.

Figure 21 • JTAG Interface Timing Diagram

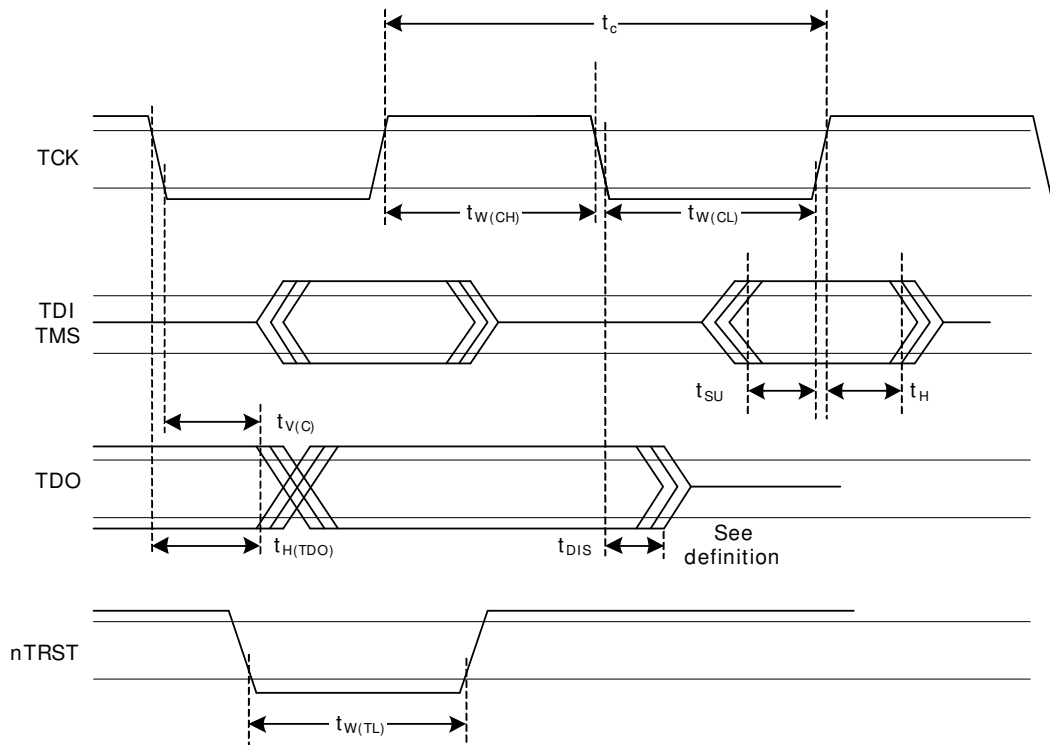
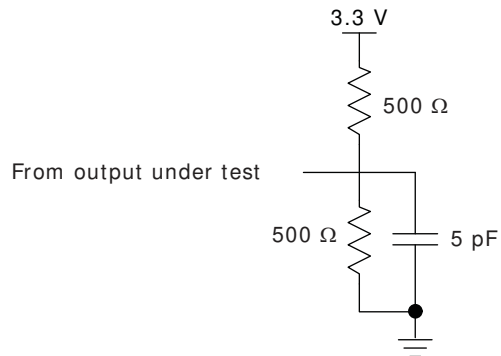

Figure 22 • Test Circuit for TDO Disable Time



4.2.7 Serial Management Interface

This section contains the AC specifications for the serial management interface (SMI).

Table 92 • Serial Management Interface

Parameter	Symbol	Minimum	Typical	Maximum	Unit	Condition
MDC frequency ⁽¹⁾	f_{CLK}		2.5	12.5	MHz	
MDC cycle time	t_{CYC}	80	400		ns	
MDC time high	t_{WH}	20	50		ns	
MDC time low	t_{WL}	20	50		ns	

Table 92 • Serial Management Interface (continued)

Parameter	Symbol	Minimum	Typical	Maximum	Unit	Condition
Setup to MDC rising	t_{SU}	10			ns	
Hold from MDC rising	t_H	10			ns	
MDC rise time	t_R			100 $t_{CYC} \times 10\%^{(1)}$	ns	MDC = 0: 1 MHz MDC = 1: MHz – f_{CLK} maximum
MDC fall time	t_F			100 $t_{CYC} \times 10\%^{(1)}$		
MDC to MDIO valid	t_{CO}		10	300	ns	Time-dependant on the value of the external pull-up resistor on the MDIO pin

1. For f_{CLK} above 1 MHz, the minimum rise time and fall time is in relation to the frequency of the MDC clock period. For example, if f_{CLK} is 2 MHz, the minimum clock rise time and fall time is 50 ns.

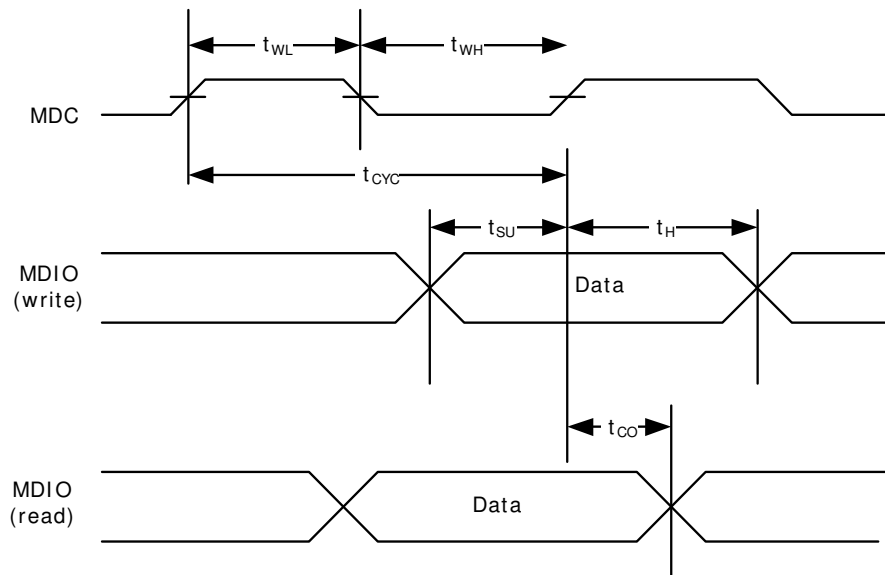
Figure 23 • Serial Management Interface Timing

4.2.8 Reset Timing

This section contains the AC specifications that apply to device reset functionality. The signal applied to the NRESET input must comply with the specifications listed in the following table.

Table 93 • Reset Timing

Parameter	Symbol	Minimum	Maximum	Unit
NRESET assertion time after power supplies and clock stabilize	t_W	2		ms
Recovery time from reset inactive to device fully active	t_{REC}		105	ms

Table 93 • Reset Timing (continued)

Parameter	Symbol	Minimum	Maximum	Unit
NRESET pulse width	$t_{W(RL)}$	100		ns
Wait time between NRESET de-assert and access of the SMI interface	t_{WAIT}	105		ms

4.3 Operating Conditions

The following table shows the recommended operating conditions for the VSC8514 device.

Table 94 • Recommended Operating Conditions

Parameter	Symbol	Minimum	Typical	Maximum	Unit
Power supply voltage for core supply	V_{VDD1}	0.95	1.00	1.05	V
Power supply voltage for digital I/O	V_{VDD25}	2.38	2.50	2.62	V
Power supply voltage for analog circuits	V_{VDD1A}	0.95	1.00	1.05	V
Power supply voltage for analog circuits	V_{VDD25A}	2.38	2.50	2.62	V
Power supply voltage for $V_{VDDMDIO}$ at 1.2 V	$V_{VDDMDIO}$	1.14	1.20	1.26	
Power supply voltage for $V_{VDDMDIO}$ at 2.5 V	$V_{VDDMDIO}$	2.38	2.50	2.62	
VSC8514 operating temperature ⁽¹⁾	T	0		125	°C
VSC8514-03 operating temperature ⁽¹⁾	T	-40		125	°C

1. Minimum specification is ambient temperature, and the maximum is junction temperature.

4.4 Stress Ratings

This section contains the stress ratings for the VSC8514 device.

Warning Stresses listed in the following table may be applied to devices one at a time without causing permanent damage. Functionality at or exceeding the values listed is not implied. Exposure to these values for extended periods may affect device reliability.

Table 95 • Stress Ratings

Parameter	Symbol	Minimum	Maximum	Unit
Power supply voltage for core supply	V_{VDD1}	-0.3	1.10	V
Power supply voltage for digital I/O	V_{VDD25}	-0.3	2.75	V
Power supply voltage for analog circuits	V_{VDD1A}	-0.3	1.10	V
Power supply voltage for analog circuits	V_{VDD25A}	-0.3	2.75	V
Power supply voltage for $V_{VDDMDIO}$	$V_{VDDMDIO}$	-0.3	2.75	V
Input voltage for GPIO and logic input pins			3.3	V
Storage temperature	T_S	-55	125	°C
Electrostatic discharge voltage, charged device model	V_{ESD_CDM}	-250	250	V
Electrostatic discharge voltage, human body model, REF_FILT pin	V_{ESD_HBM}	-1000	1000	V

Table 95 • Stress Ratings (continued)

Parameter	Symbol	Minimum	Maximum	Unit
Electrostatic discharge voltage, human body model, all pins except the REF_FILT pin	V _{ESD_HBM}		See note ⁽¹⁾	V

1. *This device has completed all required testing as specified in the JEDEC standard JESD22-A114, Electrostatic Discharge (ESD) Sensitivity Testing Human Body Model (HBM), and complies with a Class 2 rating. The definition of Class 2 is any part that passes an ESD pulse of 2000 V, but fails an ESD pulse of 4000 V.*

Warning This device can be damaged by electrostatic discharge (ESD) voltage. Microsemi recommends that all integrated circuits be handled with appropriate precautions. Failure to observe proper handling and installation procedures may adversely affect reliability of the device.

5 Pin Descriptions

The VSC8514 device has 138 pins, which are described in this section.



The pin information is also provided as an attached Microsoft Excel file so that you can copy it electronically. In Acrobat, double-click the attachment icon.

5.1 Pin Identifications

This section contains the pin descriptions for the VSC8514 device. The following table provides notations for definitions of the various pin types.

Table 96 • Pin Type Symbol Definitions

Symbol	Pin Type	Description
A	Analog	Analog pin.
ABIAS	Analog bias	Analog bias pin.
ADIFF	Analog differential	Analog differential signal pair.
I	Input	Input without on-chip pull-up or pull-down resistor.
I/O	Bidirectional	Bidirectional input or output signal.
NC	No connect	No connect pins must be left floating.
O	Output	Output signal.
OD	Open drain	Open drain output.
OS	Open source	Open source output.
PD	Pull-down	On-chip pull-down resistor to VSS.
PU	Pull-up	On-chip pull-up resistor to VDD_IO.

5.2 Pin Diagram

The following illustration shows the pin diagram for the VSC8514 device, as seen looking through the package from the top of it. Note that the exposed pad connects to the package ground.

Figure 24 • Pin Diagram

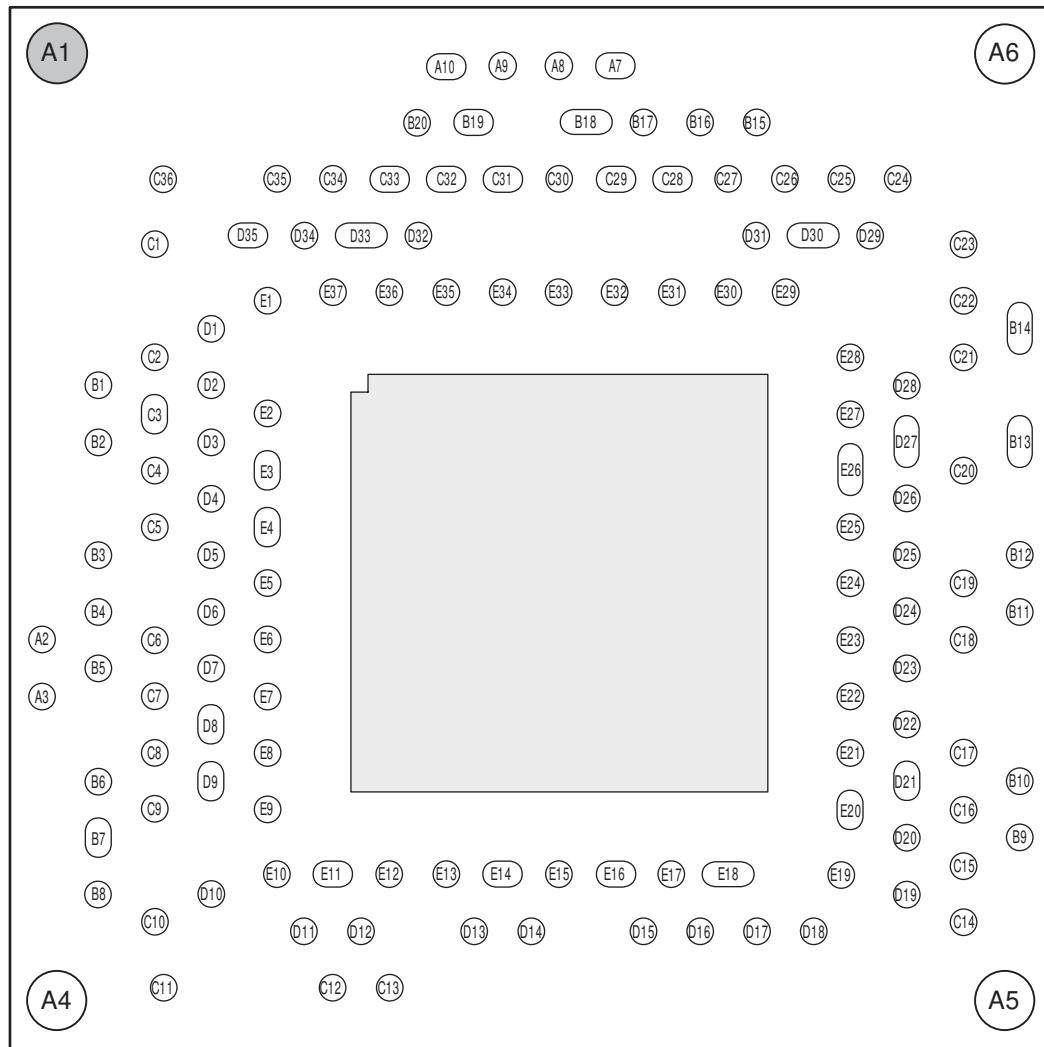

5.3 Pins by Function

This section contains the functional pin descriptions for the VSC8514 device.

5.3.1 Copper PHY Media

The following table lists the copper PHY media pins.

Table 97 • Copper PHY Media Pins

Name	Pin	Type	Description
P0_D0N	D30	A	PHY 0 Tx/Rx channel A negative signal
P0_D0P	D31	A	PHY 0 Tx/Rx channel A positive signal
P0_D1N	C24	A	PHY 0 Tx/Rx channel B negative signal
P0_D1P	C25	A	PHY 0 Tx/Rx channel B positive signal
P0_D2N	C23	A	PHY 0 Tx/Rx channel C negative signal

Table 97 • Copper PHY Media Pins (continued)

Name	Pin	Type	Description
P0_D2P	D29	A	PHY 0 Tx/Rx channel C positive signal
P0_D3N	C21	A	PHY 0 Tx/Rx channel D negative signal
P0_D3P	C22	A	PHY 0 Tx/Rx channel D positive signal
P1_D0N	B17	A	PHY 1 Tx/Rx channel A negative signal
P1_D0P	B18	A	PHY 1 Tx/Rx channel A positive signal
P1_D1N	C28	A	PHY 1 Tx/Rx channel B negative signal
P1_D1P	C29	A	PHY 1 Tx/Rx channel B positive signal
P1_D2N	B15	A	PHY 1 Tx/Rx channel C negative signal
P1_D2P	B16	A	PHY 1 Tx/Rx channel C positive signal
P1_D3N	C26	A	PHY 1 Tx/Rx channel D negative signal
P1_D3P	C27	A	PHY 1 Tx/Rx channel D positive signal
P2_D0N	C32	A	PHY 2 Tx/Rx channel A negative signal
P2_D0P	C33	A	PHY 2 Tx/Rx channel A positive signal
P2_D1N	B19	A	PHY 2 Tx/Rx channel B negative signal
P2_D1P	B20	A	PHY 2 Tx/Rx channel B positive signal
P2_D2N	A9	A	PHY 2 Tx/Rx channel C negative signal
P2_D2P	A10	A	PHY 2 Tx/Rx channel C positive signal
P2_D3N	C30	A	PHY 2 Tx/Rx channel D negative signal
P2_D3P	C31	A	PHY 2 Tx/Rx channel D positive signal
P3_D0N	C36	A	PHY 3 Tx/Rx channel A negative signal
P3_D0P	C1	A	PHY 3 Tx/Rx channel A positive signal
P3_D1N	D34	A	PHY 3 Tx/Rx channel B negative signal
P3_D1P	D35	A	PHY 3 Tx/Rx channel B positive signal
P3_D2N	C34	A	PHY 3 Tx/Rx channel C negative signal
P3_D2P	C35	A	PHY 3 Tx/Rx channel C positive signal
P3_D3N	D32	A	PHY 3 Tx/Rx channel D negative signal
P3_D3P	D33	A	PHY 3 Tx/Rx channel D positive signal

5.3.2 GPIO

The following table lists the general purpose input and output (GPIO) pins.

Table 98 • GPIO Pins

Name	Pin	Type	Description
GPIO[0:8]	D19, C14, D20, C15, B9, C16, D21, B10, C17	I/O, PU	General purpose input/output (GPIO)
GPIO9/FASTLINK_FAIL	D22	I/O, PU	General purpose input/output (GPIO) also used to output the FASTLINK_FAIL signal
GPIO[10:14]	D24, D23, C18, B11, D25	I/O, PU	General purpose input/output (GPIO)

5.3.3 JTAG

The following table lists the JTAG test pins.

Table 99 • JTAG Pins

Name	Pin	Type	Description
TCK	B6	I, PU	JTAG test clock input
TDI	C9	I, PU	JTAG test serial data input
TDO	C8	O	JTAG test serial data output
TMS	A3	I, PU	JTAG test mode select
TRST	C7	I, PU	JTAG reset

Important When JTAG is not in use, this pin must be tied to ground with a pull-down resistor

5.3.4 Miscellaneous

The following table lists the miscellaneous pins.

Table 100 • Miscellaneous Pins

Name	Pin	Type	Description
CLK_SQUELCH_IN	D27	I, PD	Input control to squelch recovered clock.
LED0_PHY[0:3]	E2, C3, C5, B4,	O	LED direct-drive outputs. All LEDs pins are active-low. A serial LED stream can also be implemented. See "LED Mode Select" on page 3-42. Note LEDbit_port, where port = PHY port number and bit = the particular LED for the port.
LED1_PHY[0:3]	D1, B2, D5, C6,		
LED2_PHY[0:3]	D2, C4, B3, A2,		
LED3_PHY[0:3]	C2, D4, D6, D7		
RCVRDCLK1	B13	O	Clock output can be enabled or disabled and also output a clock frequency of 125 MHz or 25 MHz. This pin is not active when NRESET is asserted. When disabled, the pin is held low.
RCVRDCLK2	C20		
REFCLK_N	D12	I,	Reference clock input differential pair. Must be capacitively coupled and LVDS compliant.
REFCLK_P	D11	ADIFF	
REFCLK_SEL[0:1]	B8, B7	I, PD	Reference clock frequency select signal for bit 0:1.
REF_FILT	A7	ABIAS	Reference filter connects to an external 1 μ F capacitor to analog ground.
REF_REXT	A8	ABIAS	Reference signal connects to an external 2 k Ω (1%) resistor to analog ground.
RESERVED_[1:4]	C12, C13, D28, B14	NC	Reserved signal. Leave unconnected.
SERDES_REXT_0	D17	ABIAS	SerDes bias pins. Connect to a 620 Ω 1% resistor.
SERDES_REXT_1	D18		
THERMDA	B1	I	Thermal diode anode.
THERMDC_VSS	D3	I	Thermal diode cathode connected to device ground. Temperature sensor must be chosen accordingly.

5.3.5 No Connect

The following table lists the no connect pins.

Table 101 • No Connect Pins

Name	Pin	Description
NC_[1:4]	A1, A4, A5, A6	Leave unconnected

5.3.6 PHY Configuration

The following table lists the PHY configuration pins.

Table 102 • PHY Configuration Pins

Name	Pin	Type	Description
COMA_MODE	D8	I, PU	When this pin is asserted high, all PHYs are held in a powered down state. When de-asserted low, all PHYs are powered up and resume normal operation. This signal is also used to synchronize the operation of multiple chips on the same PCB to provide visual synchronization for LEDs driven by separate chips. ⁽¹⁾
NRESET	B5	I, PD	Device reset. Active low input that powers down the device and sets all register bits to their default state.
PHYADD2	C19	I, PD	Device SMI address bits 4:2.
PHYADD3	B12		
PHYADD4	D26		

1. For more information, see "Initialization" on page 2-25. For information about a typical bring-up example, see "Configuration" on page 2-25.

5.3.7 Power Supply and Ground

The following table lists the power supply pins and associated functional pins. All power supply pins must be connected to their respective voltage input, even if certain functions are not used for a specific application. No power supply sequencing is required. However, clock and power must be stable before releasing Reset.

Table 103 • Power Supply and Ground Pins

Name	Pin	Description
VDD1	E5, E7, E10, E13, E15, E17, E19, E21, E23, E25	1.0 V digital core power supply
VDD1A	E1, E11, E14, E16, E28, E30, E32, E34, E36	1.0 V analog power requiring additional PCB power supply filtering
VDD25	E3, E4, E6, E8, E12, E18, E20, E22, E24, E26	2.5 V general digital power supply
VDD25A	E27, E29, E31, E33, E35, E37	2.5 V general analog power supply
VDDMDIO	E9	1.2 V or 2.5 V power for SMI pins
VSS_CASE	Exposed pad, D9	Common device ground

5.3.8 QSGMII MAC Interface

The following table lists the SerDes MAC interface pins.

Table 104 • SerDes MAC Interface Pins

Name	Pin	Type	Description
RDN_0	D13	A	QSGMII MAC receiver output pair
RDP_0	D14		
TDN_0	D15	A	QSGMII MAC transmitter input pair
TDP_0	D16		

5.3.9 Serial Management Interface

The following table lists the serial management interface (SMI) pins. The SMI pins are referenced to VDD25 and can be set to a 2.5 V power supply.

Table 105 • SMI Pins

Name	Pin	Type	Description
MDC	C11	I, PD	Management data clock. A 0 MHz to 12.5 MHz reference input is used to clock serial MDIO data into and out of the PHY.
MDINT	C10	I/O, OS, OD	Management interrupt signal. Upon reset the device configures these pins as active-low (open drain). This pin can be tied together in a wired-OR configuration with only a single pull-up resistor.
MDIO	D10	I/O, OD	Management data input/output pin. Serial data is written or read from this pin bidirectionally between the PHY and station manager, synchronously on the positive edge of MDC. One external pull-up resistor is required at the station manager, and its value depends on the MDC clock frequency and the total sum of the capacitive loads from the MDIO pins.

6 Package Information

VSC8514XMK and VSC8514XMK-03 are packaged in a lead-free (Pb-free), 138-pin, multi-row plastic quad flat no-lead (QFN) package with an exposed pad, 12 mm × 12 mm body size, 0.65 mm pin pitch, and 0.85 mm maximum height.

Lead-free products from Microsemi comply with the temperatures and profiles defined in the joint IPC and JEDEC standard IPC/JEDEC J-STD-020. For more information, see the IPC and JEDEC standard.

This section provides the package drawing, thermal specifications, and moisture sensitivity rating for the VSC8514 device.

6.1 Package Drawing

The following illustration shows the package drawing for the device. The drawing contains the top view, bottom view, side view, detail views, dimensions, tolerances, and notes.

Figure 25 • Package Drawing

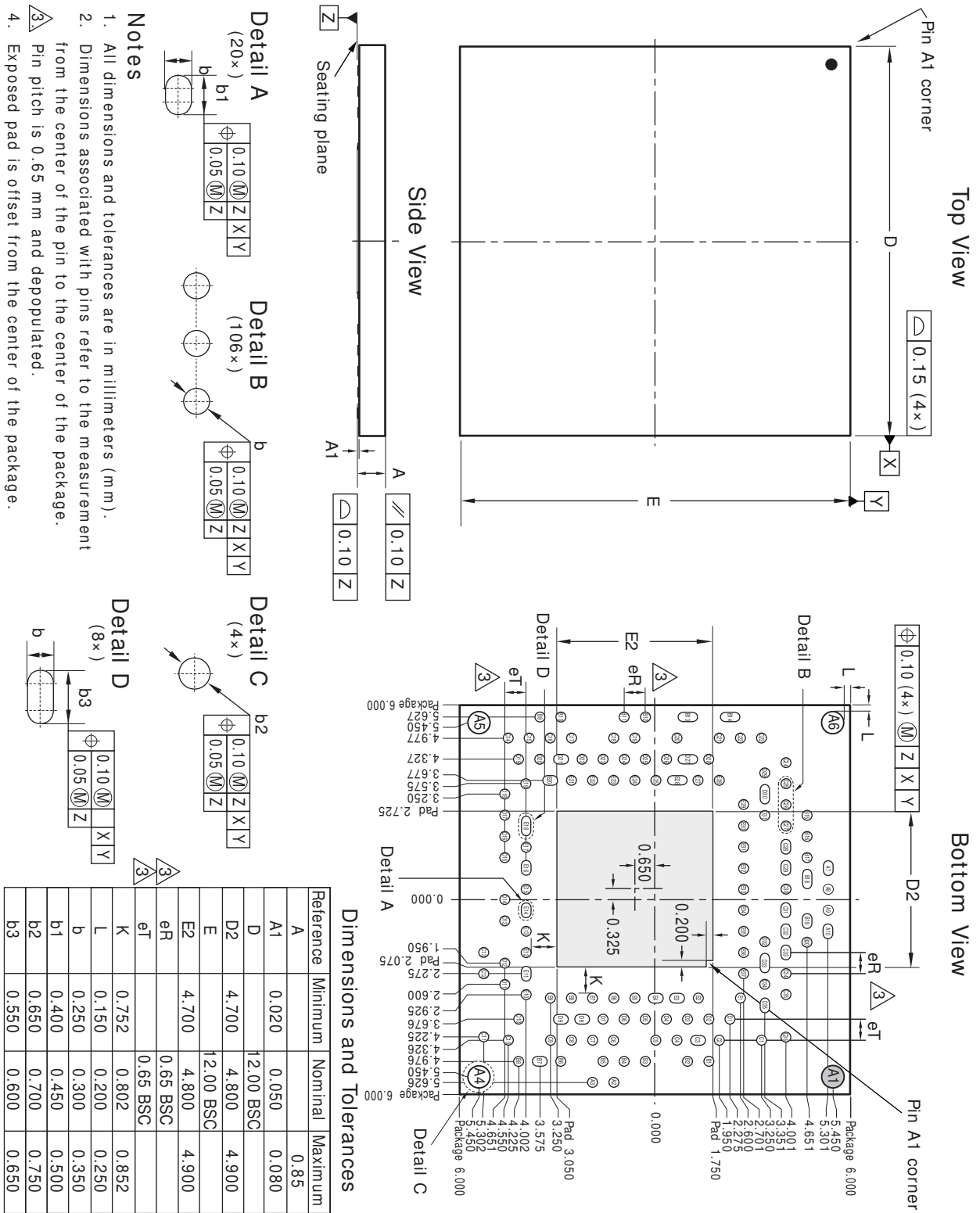

6.2 Thermal Specifications

Thermal specifications for this device are based on the JEDEC JESD51 family of documents. These documents are available on the JEDEC Web site at www.jedec.org. The thermal specifications are modeled using a four-layer test board with two signal layers, a power plane, and a ground plane (2s2p PCB). For more information about the thermal measurement method used for this device, see the JESD51-1 standard.

Table 106 • Thermal Resistances

Symbol	°C/W	Parameter
θ_{JCTop}	19.7	Die junction to package case top
θ_{JB}	7.33	Die junction to printed circuit board
θ_{JA}	23.2	Die junction to ambient
θ_{JMA} at 1 m/s	18.15	Die junction to moving air measured at an air speed of 1 m/s
θ_{JMA} at 2 m/s	15.65	Die junction to moving air measured at an air speed of 2 m/s

To achieve results similar to the modeled thermal measurements, the guidelines for board design described in the JESD51 family of publications must be applied. For information about applications using QFN packages, see the following:

- JESD51-2A, *Integrated Circuits Thermal Test Method Environmental Conditions, Natural Convection (Still Air)*
- JESD51-6, *Integrated Circuit Thermal Test Method Environmental Conditions, Forced Convection (Moving Air)*
- JESD51-8, *Integrated Circuit Thermal Test Method Environmental Conditions, Junction-to-Board*
- JESD51-7, *High Effective Thermal Conductivity Test Board for Leaded Surface Mount Packages*
- JESD51-5, *Extension of Thermal Test Board Standards for Packages with Direct Thermal Attachment Mechanisms*

6.3 Moisture Sensitivity

This device is rated moisture sensitivity level 3 or better as specified in the joint IPC and JEDEC standard IPC/JEDEC J-STD-020. For more information, see the IPC and JEDEC standard.

7 Design Considerations

This section provides information about design considerations for the VSC8514 device.

10BASE-T signal amplitude

10BASE-T signal amplitude can be lower than the minimum specified in IEEE 802.3 paragraph 14.3.1.2.1 (2.2 V) at low supply voltages.

This issue is not estimated to present any system level impact. Performance is not impaired with cables up to 130 m with various link partners.

PHY0 initialization after reset from power up

On some devices, register 0 in PHY0 does not get initialized to the correct default state and is instead initialized to 0x0000. This results in the PHY being forced into a 10BASE-T half-duplex configuration.

This issue does not affect systems that use the recommended initialization sequence. For more information, see "[Configuration](#)" on [page 2-25](#). If the recommended initialization sequence is not used, reset PHY0 by setting register 0, bit 15 to logic 1 after power up and hardware reset deassertion. This will restore PHY0 to the correct default state.

Link performance in 10BASE-TX and 1000BASE-T modes

PHY ports may exhibit sub-optimal performance under certain environmental and cabling conditions without proper initialization.

Contact Microsemi for a script that needs to be applied during system initialization.

Ethernet Packet Generator control register write corruption

Writing values to extended page 1 registers 29E1 and 30E1 of one port may corrupt contents of registers 29E1 or 30E1 in another port. This is a timing-related issue and all revision A devices are susceptible to the problem.

Ethernet packet generator functionality is only used during lab testing, so broadcast writes can be used to enable EPG on all ports simultaneously.

Alternatively, EPG can be enabled on a per-port basis with the limitation that EPG control updates on a port may affect other ports of the device.

8 Ordering Information

The device is offered with two operating temperature ranges. The range for VSC8514 is 0 °C ambient to 125 °C junction. The range for VSC8514-03 is –40 °C ambient to 125 °C junction.

VSC8514XMK and VSC8514XMK-03 are packaged in a lead-free (Pb-free), 138-pin, multi-row plastic quad flat no-lead (QFN) package with an exposed pad, 12 mm × 12 mm body size, 0.65 mm pin pitch, and 0.85 mm maximum height.

Lead-free products from Microsemi comply with the temperatures and profiles defined in the joint IPC and JEDEC standard IPC/JEDEC J-STD-020. For more information, see the IPC and JEDEC standard.

The following table lists the ordering information for the device.

Table 107 • Ordering Information

Part Order Number	Description
VSC8514XMK	Lead-free, 138-pin, multi-row plastic QFN with an exposed pad, 12 mm × 12 mm body size, 0.65 mm pin pitch, and 0.85 mm maximum height. The operating temperature is 0 °C ambient to 125 °C junction.
VSC8514XMK-03	Lead-free, 138-pin, multi-row plastic QFN with an exposed pad, 12 mm × 12 mm body size, 0.65 mm pin pitch, and 0.85 mm maximum height. The operating temperature is –40 °C ambient to 125 °C junction.

9 Revision History

This section describes the changes that were implemented in this document. The changes are listed by revision, starting with the most current publication.

9.1 Revision 4.2

Revision 4.2 of this datasheet was published in February 2019. In revision 4.2, VeriPHY descriptions were updated and VeriPHY register information was deleted. For functional details of the VeriPHY suite and operating instructions, see the ENT-AN0125 PHY, Integrated PHY-Switch VeriPHY - Cable Diagnostics application note.

9.2 Revision 4.1

Revision 4.1 of this datasheet was published in August 2015. The following is a summary of the changes implemented in the datasheet:

- A minor editorial change was made to better reflect that the 2.5 V power supply (V_{VDD25A}) should be applied. For more information, see "[VDD25 and VDDMDIO \(2.5 V\)](#)" on page 4-67.
- Timeout values for ActiPHY link status timeout control registers were corrected. For more information, see [Table 38](#) on page 3-41.
- The default value for the disable carrier extension bit of the ActiPHY control register was corrected to 1. For more information, see [Table 45](#) on page 3-45.

9.3 Revision 4.0

Revision 4.0 of this datasheet was published in June 2014. The following is a summary of the changes implemented in the datasheet:

- Functional and register descriptions for the recovered clock were added.
- Functional and electrical descriptions for the reference clock were updated.
- Electrical specifications for VDD25 and VDDMDIO were updated.
- Electrical specifications for LED and GPIO pins were restated in volts (V).
- Maximum current consumption specifications were added.
- Electrical specifications for the enhanced SerDes interface were updated.
- Electrical specifications for enhanced serial LEDs were updated.
- Operating condition and stress rating specifications for VDDMDIO power supply voltage were added.
- ESD (electrostatic discharge) was added. For human body model (HBM), it is a Class 2 rating for all pins except the REF_FILT pin, which is ± 1000 V. For charged device model (CDM), it is ± 250 V.
- Moisture sensitivity level (MSL) is level 3.
- Design considerations were added.

9.4 Revision 2.1

Revision 2.1 of this datasheet was published in February 2014. The following is a summary of the changes implemented in the datasheet:

- DC specifications for the pins referenced to VDDMDIO when it is set to 1.2 V were added.

- Typical current consumption values were added.

9.5 Revision 2.0

Revision 2.0 of this datasheet was published in October 2013. This was the first publication of the document.