

AIC111EVM

User's Guide

IMPORTANT NOTICE

Texas Instruments Incorporated and its subsidiaries (TI) reserve the right to make corrections, modifications, enhancements, improvements, and other changes to its products and services at any time and to discontinue any product or service without notice. Customers should obtain the latest relevant information before placing orders and should verify that such information is current and complete. All products are sold subject to TI's terms and conditions of sale supplied at the time of order acknowledgment.

TI warrants performance of its hardware products to the specifications applicable at the time of sale in accordance with TI's standard warranty. Testing and other quality control techniques are used to the extent TI deems necessary to support this warranty. Except where mandated by government requirements, testing of all parameters of each product is not necessarily performed.

TI assumes no liability for applications assistance or customer product design. Customers are responsible for their products and applications using TI components. To minimize the risks associated with customer products and applications, customers should provide adequate design and operating safeguards.

TI does not warrant or represent that any license, either express or implied, is granted under any TI patent right, copyright, mask work right, or other TI intellectual property right relating to any combination, machine, or process in which TI products or services are used. Information published by TI regarding third-party products or services does not constitute a license from TI to use such products or services or a warranty or endorsement thereof. Use of such information may require a license from a third party under the patents or other intellectual property of the third party, or a license from TI under the patents or other intellectual property of TI.

Reproduction of information in TI data books or data sheets is permissible only if reproduction is without alteration and is accompanied by all associated warranties, conditions, limitations, and notices. Reproduction of this information with alteration is an unfair and deceptive business practice. TI is not responsible or liable for such altered documentation.

Resale of TI products or services with statements different from or beyond the parameters stated by TI for that product or service voids all express and any implied warranties for the associated TI product or service and is an unfair and deceptive business practice. TI is not responsible or liable for any such statements.

Following are URLs where you can obtain information on other Texas Instruments products & application solutions:

Products		Applications	
Amplifiers	amplifier.ti.com	Audio	www.ti.com/audio
Data Converters	dataconverter.ti.com	Automotive	www.ti.com/automotive
DSP	dsp.ti.com	Broadband	www.ti.com/broadband
Interface	interface.ti.com	Digital Control	www.ti.com/digitalcontrol
Logic	logic.ti.com	Military	www.ti.com/military
Power Mgmt	power.ti.com	Optical Networking	www.ti.com/opticalnetwork
Microcontrollers	microcontroller.ti.com	Security	www.ti.com/security
		Telephony	www.ti.com/telephony
		Video & Imaging	www.ti.com/video
		Wireless	www.ti.com/wireless

Mailing Address: Texas Instruments
Post Office Box 655303 Dallas, Texas 75265

EVM IMPORTANT NOTICE

Texas Instruments (TI) provides the enclosed product(s) under the following conditions:

This evaluation kit being sold by TI is intended for use for **ENGINEERING DEVELOPMENT OR EVALUATION PURPOSES ONLY** and is not considered by TI to be fit for commercial use. As such, the goods being provided may not be complete in terms of required design-, marketing-, and/or manufacturing-related protective considerations, including product safety measures typically found in the end product incorporating the goods. As a prototype, this product does not fall within the scope of the European Union directive on electromagnetic compatibility and therefore may not meet the technical requirements of the directive.

Should this evaluation kit not meet the specifications indicated in the EVM User's Guide, the kit may be returned within 30 days from the date of delivery for a full refund. **THE FOREGOING WARRANTY IS THE EXCLUSIVE WARRANTY MADE BY SELLER TO BUYER AND IS IN LIEU OF ALL OTHER WARRANTIES, EXPRESSED, IMPLIED, OR STATUTORY, INCLUDING ANY WARRANTY OF MERCHANTABILITY OR FITNESS FOR ANY PARTICULAR PURPOSE.**

The user assumes all responsibility and liability for proper and safe handling of the goods. Further, the user indemnifies TI from all claims arising from the handling or use of the goods. Please be aware that the products received may not be regulatory compliant or agency certified (FCC, UL, CE, etc.). Due to the open construction of the product, it is the user's responsibility to take any and all appropriate precautions with regard to electrostatic discharge.

EXCEPT TO THE EXTENT OF THE INDEMNITY SET FORTH ABOVE, NEITHER PARTY SHALL BE LIABLE TO THE OTHER FOR ANY INDIRECT, SPECIAL, INCIDENTAL, OR CONSEQUENTIAL DAMAGES.

TI currently deals with a variety of customers for products, and therefore our arrangement with the user **is not exclusive**.

TI assumes **no liability for applications assistance, customer product design, software performance, or infringement of patents or services described herein**.

Please read the EVM User's Guide and, specifically, the EVM Warnings and Restrictions notice in the EVM User's Guide prior to handling the product. This notice contains important safety information about temperatures and voltages. For further safety concerns, please contact the TI application engineer.

Persons handling the product must have electronics training and observe good laboratory practice standards.

No license is granted under any patent right or other intellectual property right of TI covering or relating to any machine, process, or combination in which such TI products or services might be or are used.

Mailing Address:

Texas Instruments
Post Office Box 655303
Dallas, Texas 75265

EVM WARNINGS AND RESTRICTIONS

It is important to operate this EVM with an input voltage of 3.3 V and the output voltage range of 0.9 V to 2.5 V, or an input voltage of 5 V and the output voltage range of 0.9 V to 3.3 V.

Exceeding the specified input range may cause unexpected operation and/or irreversible damage to the EVM. If there are questions concerning the input range, please contact a TI field representative prior to connecting the input power.

Applying loads outside of the specified output range may result in unintended operation and/or possible permanent damage to the EVM. Please consult the EVM User's Guide prior to connecting any load to the EVM output. If there is uncertainty as to the load specification, please contact a TI field representative.

During normal operation, some circuit components may have case temperatures greater than 55°C. The EVM is designed to operate properly with certain components above 60°C as long as the input and output ranges are maintained. These components include but are not limited to linear regulators, switching transistors, pass transistors, and current sense resistors. These types of devices can be identified using the EVM schematic located in the EVM User's Guide. When placing measurement probes near these devices during operation, please be aware that these devices may be very warm to the touch.

Mailing Address:

Texas Instruments
Post Office Box 655303
Dallas, Texas 75265

Read This First

About This Manual

This user's guide describes the operation and use of the AIC111 codec. A complete circuit description as well as a schematic diagram and bill of materials are also included.

How to Use This Manual

This document contains the following chapters:

- Chapter 1—Introduction
- Chapter 2—Digital Interface
- Chapter 3—Analog Interface
- Chapter 4—AIC111 Bill of Materials and Schematic

Related Documentation From Texas Instruments

To obtain a copy of any of the following TI documents, call the Texas Instruments Literature Response Center at (800) 477-8924 or the Product Information Center (PIC) at (972) 644-5580. When ordering, please identify this booklet by its title and literature number. Updated documents can also be obtained through our website at www.ti.com.

Data Sheets:

AIC111
SN74AUC1G125

Literature Number

SLAS382
SCES382F

FCC Warning

This equipment is intended for use in a laboratory test environment only. It generates, uses, and can radiate radio frequency energy and has not been tested for compliance with the limits of computing devices pursuant to subpart J of part 15 of FCC rules, which are designed to provide reasonable protection against radio frequency interference. Operation of this equipment in other environments may cause interference with radio communications, in which case the user at his own expense will be required to take whatever measures may be required to correct this interference.

Trademarks

The TI Logo is a trademark of Texas Instruments.

Contents

1	Introduction	1-1
2	Digital Interface	2-1
2.1	Codec-to-Platform	2-2
2.2	Jumper Options	2-3
3	Analog Interface	3-1
3.1	Input Connections	3-2
3.2	Output Connections	3-2
4	Bill of Materials and Schematic	4-1
4.1	Bill of Materials	4-2
4.2	Schematic	4-4

(This page has been left blank intentionally.)

Introduction

This user guide provides support for the AIC111 device.

The AIC111 features a $\Delta\Sigma$ ADC & DAC, a programmable time-constant PGA/compressor interface, and a glueless interface to many DSPs.

The device featured on the EVM is a 5x5 QFN (quad flatpack no leads)

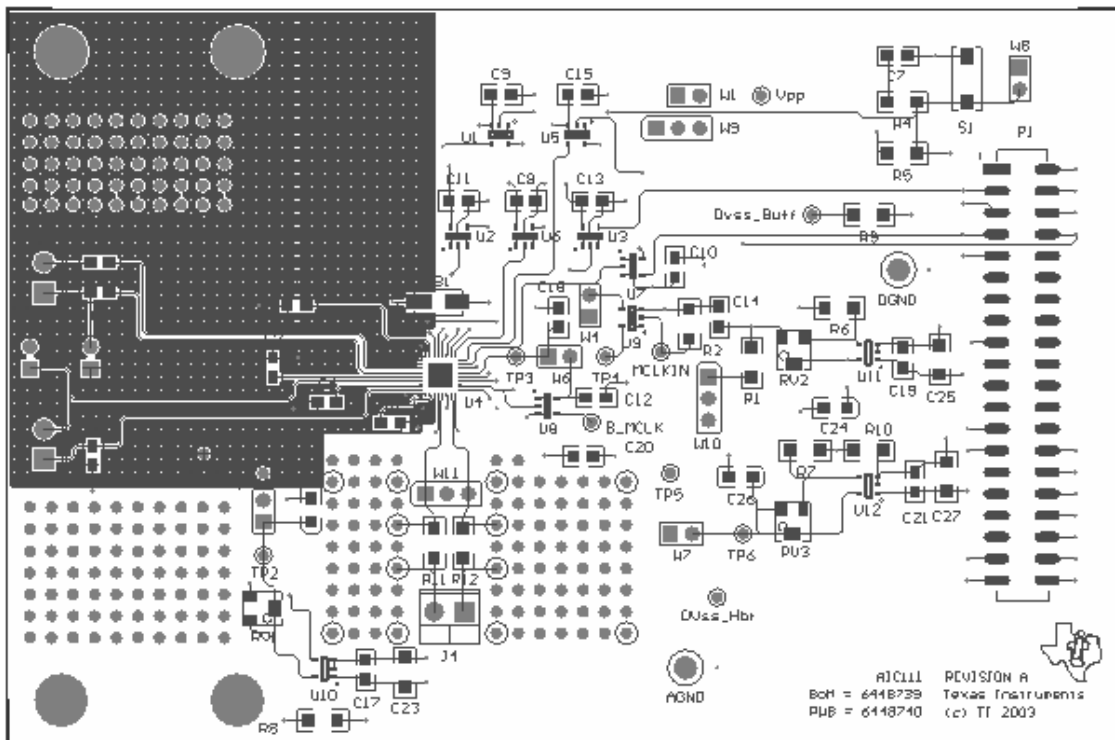

(This page has been left blank intentionally.)

Digital Interface

The digital signals required to operate this codec originate from the 40-pin connector – J1. There are two methods to drive the digital interface:

- Create a custom interface between the codec EVM and the host system.
- Alternatively, if a TI DSK (DSP starter kit) is the host system, a development platform is available from TI. This platform provides the additional functions that the codec requires in a convenient form factor.

Topic	Page
2.1 Codec-to-Platform	2-2
2.1 Jumper Options	2-3

2.1 Codec-to-Platform

The AIC111 mates with the development platform via a 40-pin Samtec connector. The mating connector (Samtec part number, TSM-120-01-T-DV-P) is used on the development platform to provide the electrical connections necessary. Consult Samtec at www.samtec.com or 1-800-SAMTEC-9 for more information.

The pinout for the 40-pin connector is given below.

Pin Number	Signal	Description
J1.1	Not used	
J1.2	DGND	Digital ground
J1.3	SCLK	Serial data clock
J1.4	DGND	Digital ground
J1.5	DIN	Data in
J1.6	DGND	Digital ground
J1.7	DOUT	Data out
J1.8	LBM	Low battery monitor
J1.9	Not used	Frame sync
J1.10	Not used	
J1.11	Not used	
J1.12	Not used	
J1.13	Not used	
J1.14	Not used	
J1.15	Not used	
J1.16	Not used	
J1.17	Not used	
J1.18	Not used	
J1.19	Not used	
J1.20	Not used	
J1.21	Not used	
J1.22	Not used	
J1.23	Not used	
J1.24	Not used	
J1.25	3.3V_D	Digital 3.3 V
J1.26	Reserved	Reserved for future use
J1.27	3.3V_D	Digital 3.3 V
J1.28	DGND	Digital ground
J1.29	Not used	
J1.30	DGND	Digital ground
J1.31	Not used	
J1.32	DGND	Digital ground
J1.33	Not used	
J1.34	AGND	Analog ground
J1.35	Not used	
J1.36	AGND	Analog ground
J1.37	3.3V_A	Analog 3.3 V
J1.38	AGND	Analog ground

Pin Number	Signal	Description
J1.39	3.3V_A	Analog 3.3 V
J1.40	AGND	Analog Ground

The development platform provides a convenient mechanical and electrical interface between the serial port on the DSK and the EVM.

Refer to Ti literature number SLAU090 for details regarding the development platform.

Further descriptions regarding the operation of this EVM assumes that the Development Platform is used. The figure below shows the method necessary to connect the DSK to the development platform, and the development platform to the codec.

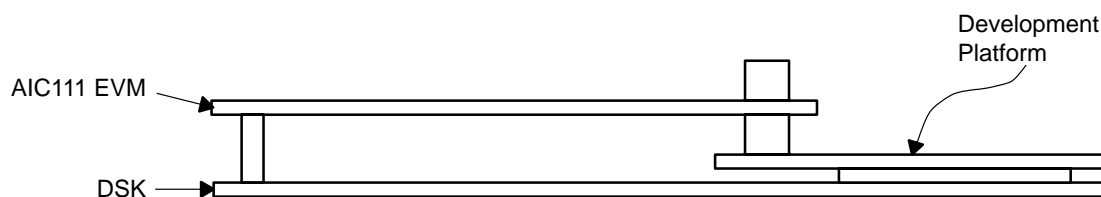

2.2 Jumper Options

There are various jumpers on the board that can be configured in a variety of ways, depending upon the user's requirements. Their functions are briefly presented below:

Jumper	Function	
W1	Reserved, never install a jumper at this location	Never install
W2	Supplies bias voltage for AVIN_P, if required	Not installed
W3	Grounds AVIN_M, for single-ended input, if required.	Not installed
W4	Reserved, never install a jumper at this location	Never install
W5	Completes the connection for the codec's analog and core digital supplies. – remove this jumper and place a current meter between TP1 and TP2 to check current drawn.	Installed
W6	Completes the connection for the codec's digital I/O supply. – remove this jumper and place a current meter between TP3 and TP4 to check current drawn.	Installed
W7	Completes the connection for the codec's digital H-bridge supply – remove this jumper and place a current meter between TP5 and TP6 to check current drawn.	Installed
W8	When inserted, the device is permanently reset.	Not installed
W9	Reserved, never install a jumper at this location	Never install
W10	Selects the digital interface	Install between pins 2 and 3
W11	Input for add-on conditioning board	Never install
P1.32–P1.34	Connect AGND and DGND together	Installed

(This page has been left blank intentionally.)

Analog Interface

Topic	Page
3.1 Input Connections	3-2
3.2 Output Connections	3-2

3.1 Input Connections

Analog input is via a screw terminal – J2. The input can be single ended or differential.

Bias current and voltage for an external microphone is provided via a screw terminal – J3.

3.2 Output Connections

The output from the AIC111 is from an H-bridge driver. These output topologies generally require a filter to recover the analog output signal. The output signal is available at J4.

The prototype area on the EVM can be used to build a simple filter, or alternatively, it is possible to build a small conditioning board which fits on top of the prototype area. Check with the factory for availability of filter boards.

Convenient points for picking-up the H-bridge ground are located around the prototype area and are indicated on the silkscreen by circles around the plated through holes.

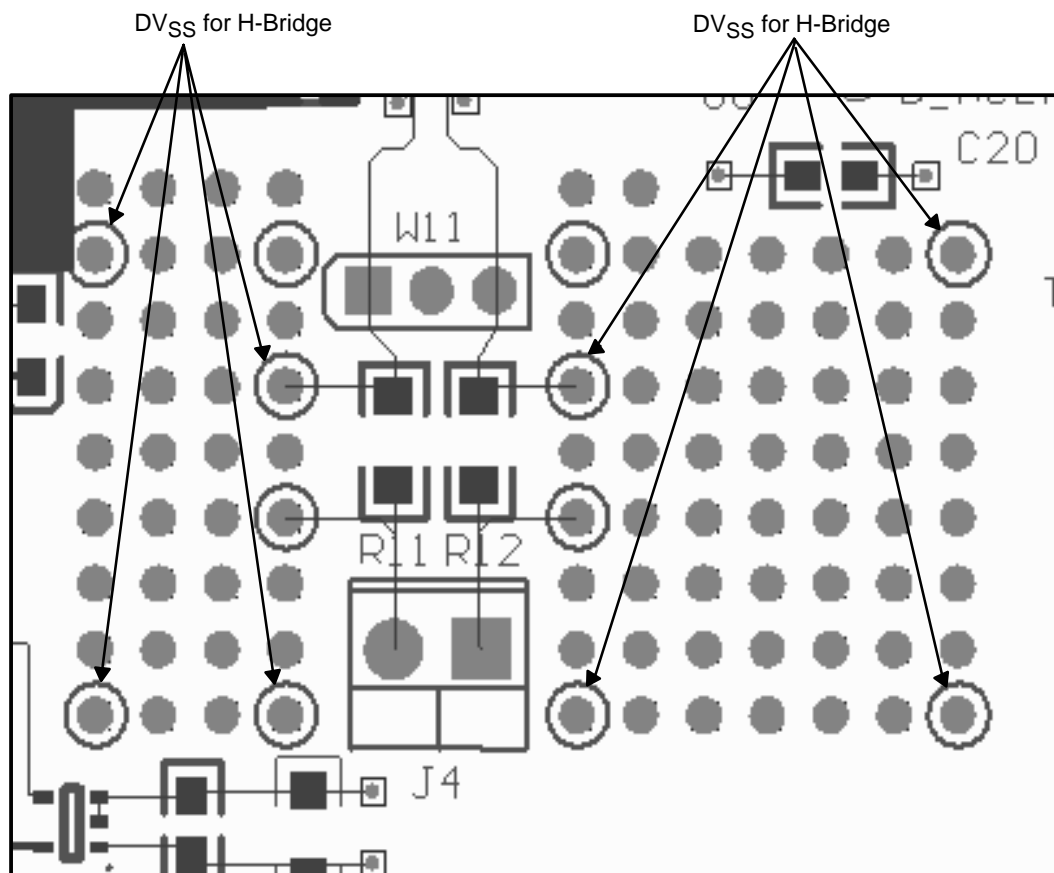

Bill of Materials and Schematic

The bill of materials and schematic for the AIC111EVM are provided in this chapter.

Topic	Page
4.1 Bill of Materials	4-2
4.2 Schematic	4-4

4.1 Bill of Materials

The following table contains a complete Bill of Materials for the AIC111EVM. The schematic diagram is also provided for reference. Contact the Product Information Center or e-mail dataconvapps@list.ti.com for questions regarding this EVM.

Used	Value	Ref Des	Description	Vendor	Part Number
6	0R	R1 R8 R9 R10 R11 R12	Resistor 0 Ω 1/8W 5% 1206 SMD	Panasonic	ERJ-8GEY0R00V
1	10K	R2	Resistor 10 k Ω 1/8W 5% 1206 SMD	Panasonic	ERJ-8GEYJ103V
2	61.9K	R6 R7	Resistor 61.9 k Ω 1/8W 1% 1206 SMD	Panasonic	ERJ-8ENF6192V
1	130K	R5	Resistor 130 k Ω 1/4W 5% 1206 SMD	Panasonic	ERJ-8GEYJ134V
2	169K	R3 R4	Resistor 169 k Ω 1/8W 1% 1206 SMD	Panasonic	ERJ-8ENF1693V
3	100K	RV1 RV2 RV3	TRIMPOT 100 k Ω 4MM TOP ADJ SMD	Bourns	3214W-1-104E
3	0.047 μ F	C23 C25 C27	Capacitor 47000 pF 50 V ceramic X7R 1206	Kemet	C1206C473K5RACTU
13	0.1 μ F	C6 C7 C8 C9 C10 C11 C12 C13 C14 C15 C16 C18 C20	Capacitor 0.1 μ F 25 V ceramic X7R 0805	Panasonic	ECJ-2YB1H104K
5	1 μ F	C1 C2 C3 C4 C5	Capacitor 1 μ F 10 V Ceramic X5R 0805	Panasonic	ECJ-2YB1A105K
3	4.7 μ F	C22 C24 C26	Solid tantalum capacitor, ESR = 3.5R	Kemet	T494A475(1)006AS
3	NI	C17 C19 C21	*	*	*
1	SM_FB_2773044447	FB1	Fair-Rite SM beads #24--44447	Fair-Rite	2744044447
8	SN74AUC1G125	U1 U2 U3 U5 U6 U7 U8 U9	Single bus buffer with 3-state output	Texas Instruments	SN74AUC1G125DBVR
3	TPS77001	U10 U11 U12	Ultralow power 50-mA LDO regulator	Texas Instruments	TPS77001DBVT
1	AIC111	U4	Codec	Texas Instruments	AIC111
1			PWB	Texas Instruments	6448740
8	2POS_JUMPER	W1 W2 W3 W4 W5 W6 W7 W8	2-position jumper	Samtec	TSW-102-07-L-S
3	3POS_JUMPER	W9 W10 W11	3-position jumper	Samtec	TSW-103-07-L-S
1	40-Pin plug	P1	40-PIN SMT PLUG	Samtec	TSM-120-01-T-DV-P
1	40-Pin socket	J1	40-Pin SMT socket	Samtec	SSW-120-22-F-D-VS-K
3	Screw terminal 2X1	J2 J3 J4	2-pole screw terminal 3,5 mm pitch black	On Shore Technology	ED-555-2-BK

Used	Value	Ref Des	Description	Vendor	Part Number
1	SW-PB	S1	Switch LT TOUCH 6X3.5 240GF SMD	Panasonic	EVQ-PJU04K
12	TP_0.025	AVss B_MCLK DVss_Hbr Dvss_Buff MCLKIN TP1 TP2 TP3 TP4 TP5 TP6 Vpp	Test Point - single 0.025" pin	Keystone Electronics	5000
2	TP_TURRENT	AGND DGND	Turret terminal test point	Cambion	180-7337-02-05
5			Shunt	Samtec	SNT-100-BK-T
2			1.000/4-40 nylon hex thread SP	Keystone Electronics	1902E
2			4-40 X 1/4 machine screw PH SS	Building Fasteners	PMSSS 440 0025 PH

4.2 Schematic

The schematics are shown on the following pages.

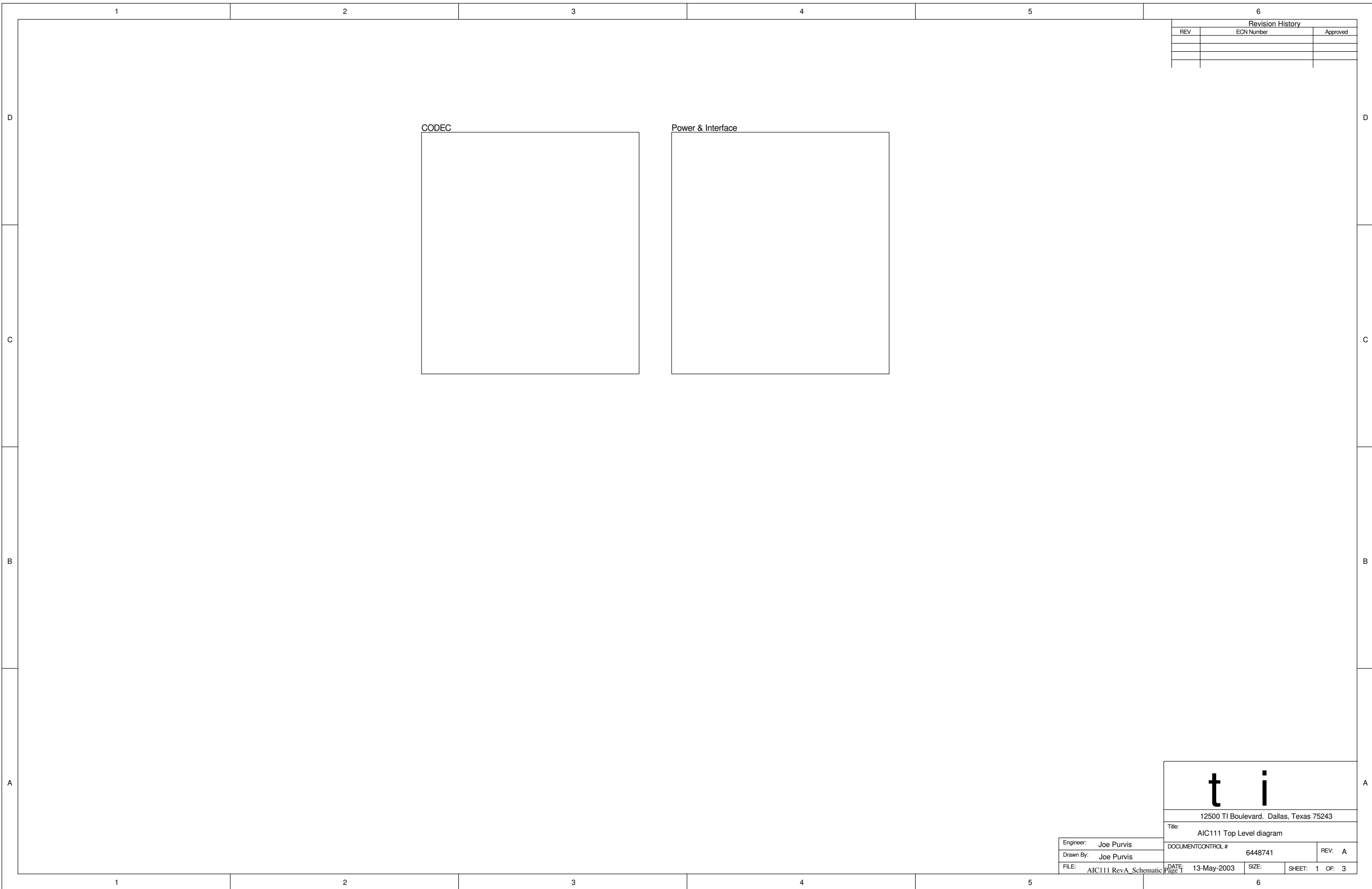

Revision History		
REV	ECN Number	Approved

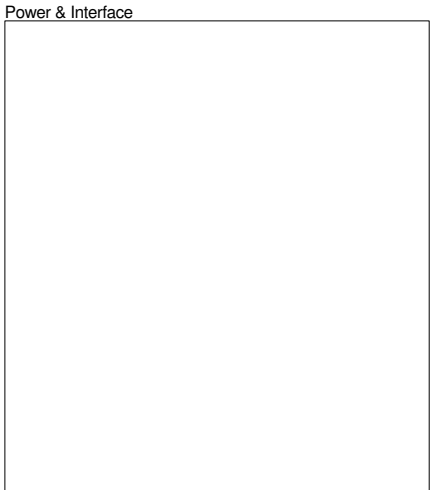
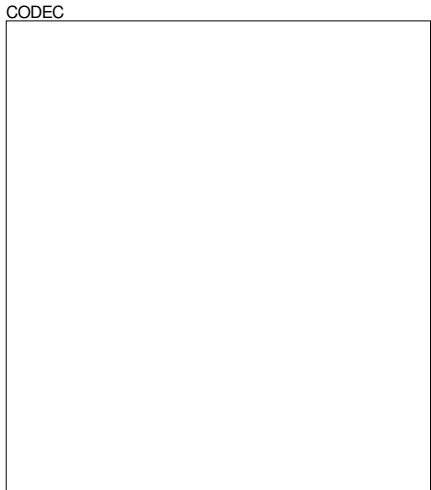

t i	
12500 TI Boulevard, Dallas, Texas 75243	
Title: AIC111 Top Level diagram	
Engineer: Joe Purvis	DOCUMENT CONTROL # 6448741
Drawn By: Joe Purvis	REV: A
FILE: AIC111 RevA Schematic Page 1	DATE: 13-May-2003
SIZE: 1	SHEET: 1 OF: 3

Engineer: Joe Purvis	DOCUMENT CONTROL # 6448741	REV: A
Drawn By: Joe Purvis	DATE: 13-May-2003	SIZE: 1
FILE: AIC111 RevA Schematic Page 1	SHEET: 1	OF: 3

Revision History		
REV	ECN Number	Approved

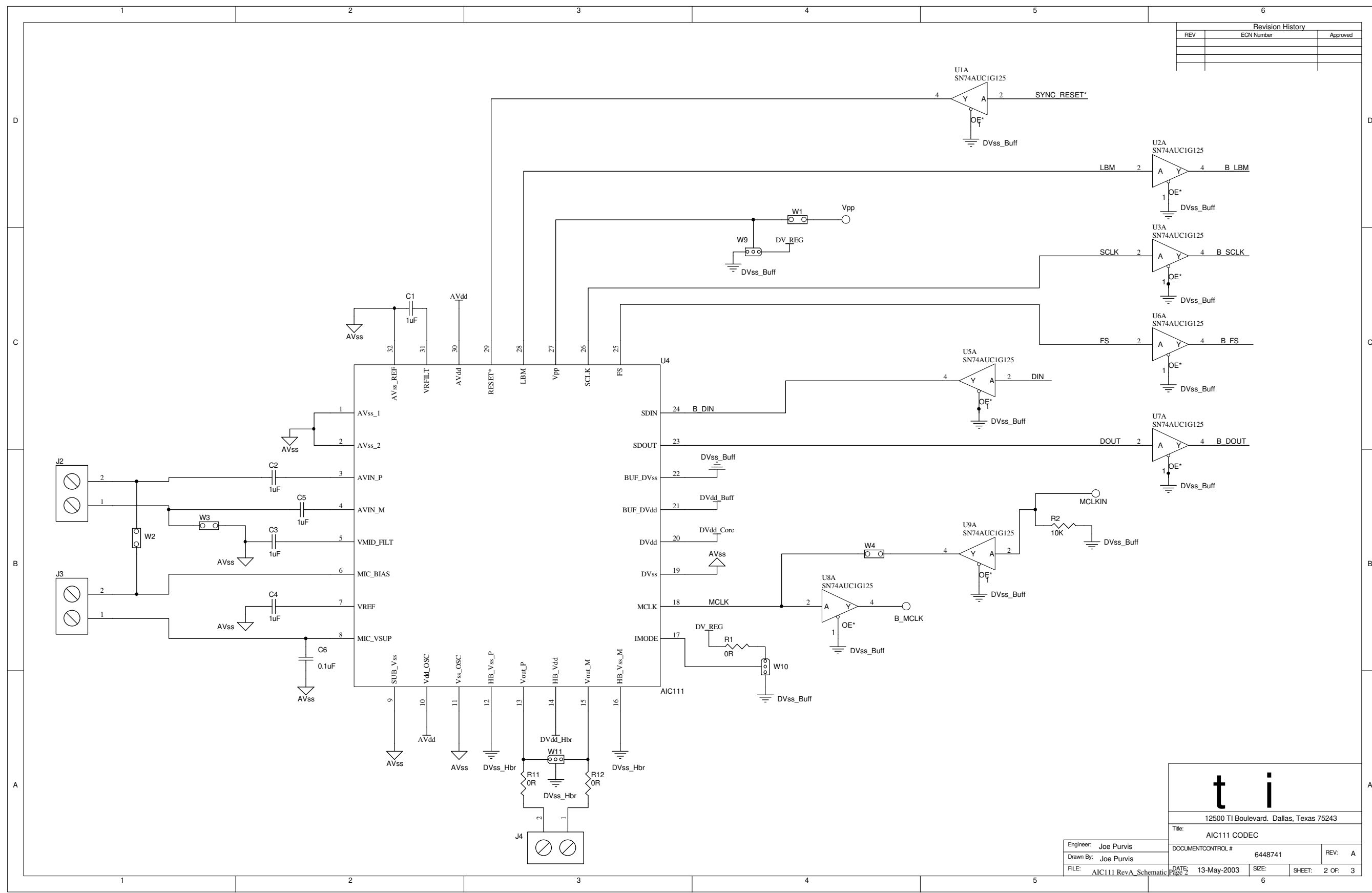

t i

12500 TI Boulevard, Dallas, Texas 75243

Title: AIC111 CODEC

Engineer: Joe Purvis DOCUMENT CONTROL # 6448741 REV: A

Drawn By: Joe Purvis

FILE: AIC111 Rev A Schematic Page 2 DATE: 13-May-2003 SIZE: SHEET: 2 OF 3

Revision History		
REV	ECN Number	Approved

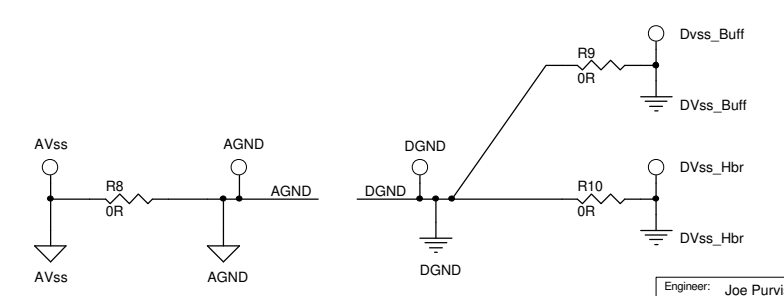
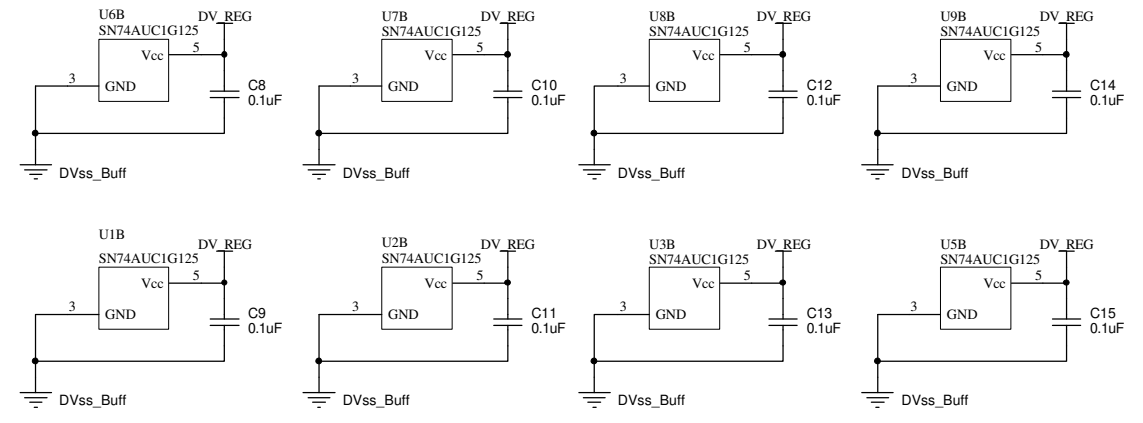
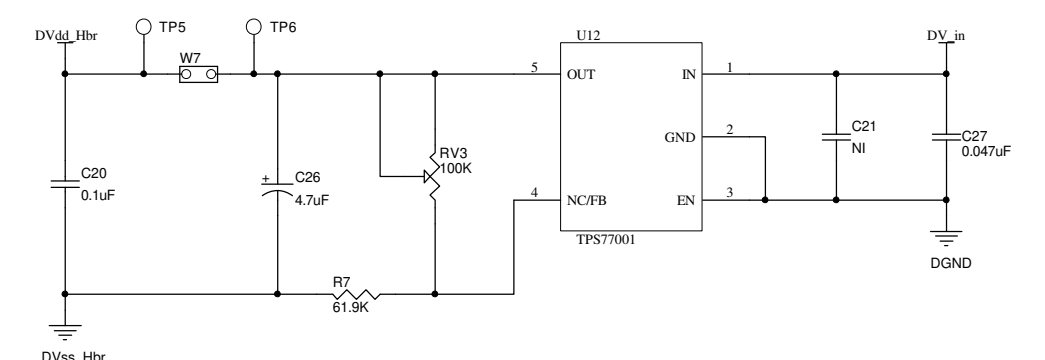
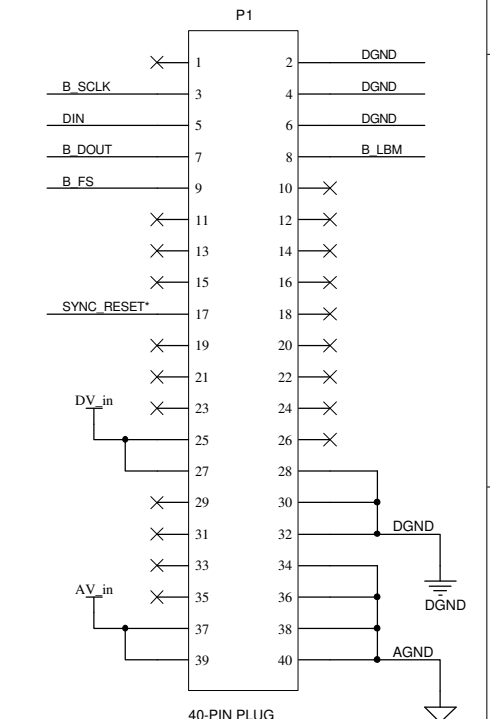
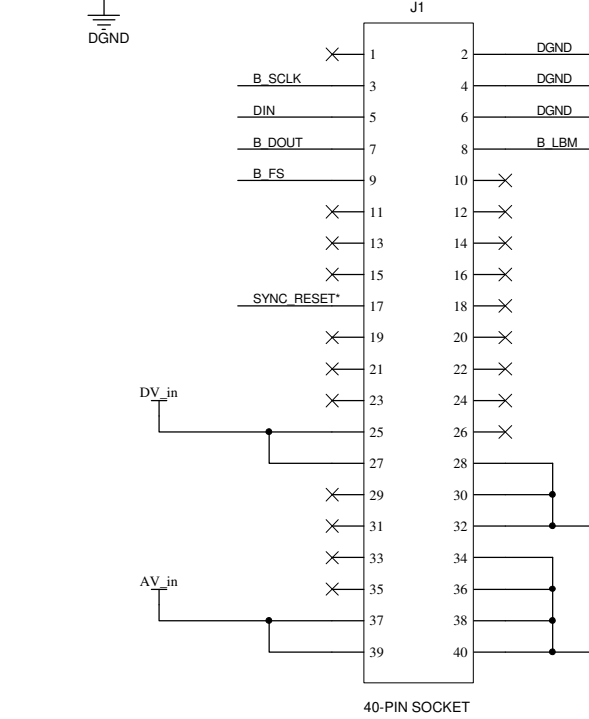
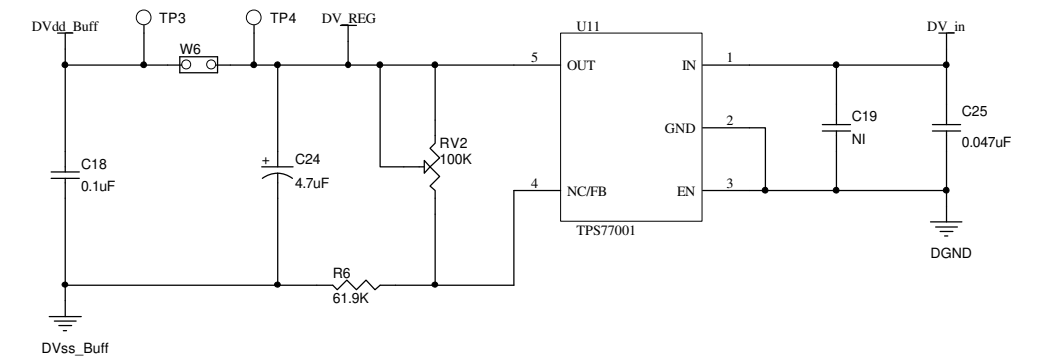
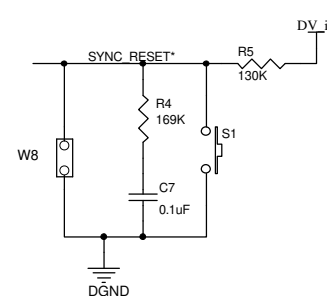
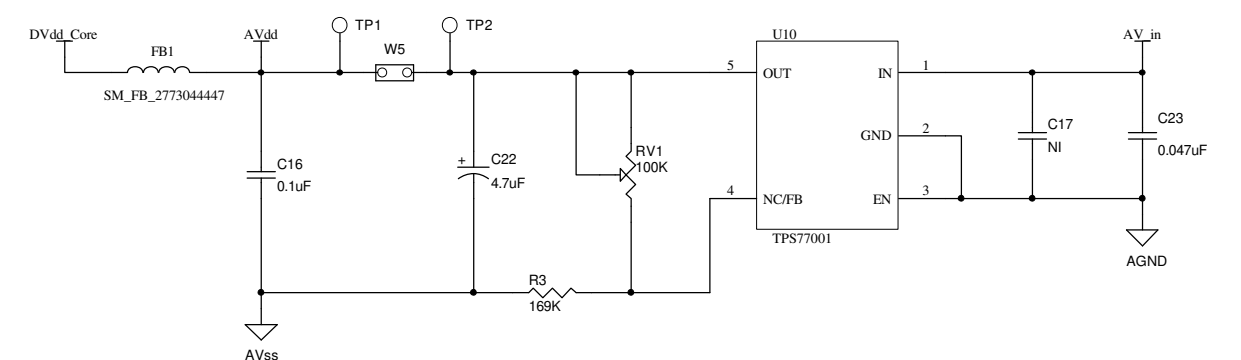

t i

12500 TI Boulevard, Dallas, Texas 75243

Title: AIC111 DSP Interface & Power

DOCUMENT CONTROL # 6448741 REV: A

Engineer: Joe Purvis
 Drawn By: Joe Purvis
 DATE: 13-May-2003
 FILE: AIC111 RevA Schematic Page 3

SIZE: SHEET: 3 OF: 3