

STDRIVE101 demonstration board for three-phase brushless motors



Features

- Input bus voltage from 6 V to 75 V with dedicated monitoring
- Output current up to 20 A_{rms} – Power stage based on the STL110N10F7 power MOSFETs
- STDRIVE101 embedded features:
 - Two input strategies (enable / input with adjustable deadtime generation or direct driving with interlocking)
 - V_{DS} sensing of the power MOSFETs
 - Overcurrent protection with internal comparator
- Three-shunt or single-shunt configurable current sensing
- BEMF or Digital Hall sensor circuitries
- NTC sensor for PCB temperature monitoring
- Motor control connector compatible with a wide range of STM32 boards and systems

Application

- Power tools
- e-Bikes
- Fans and home appliances

Description

The EVALSTDRIVE101 is a demonstration board based on the STDRIVE101, a three-phase gate driver, and the STL110N10F7 power MOSFETs.

The EVALSTDRIVE101 is designed to drive three-phase brushless DC motors and it can be interfaced with different STM32 microcontrollers through the motor control connector.

The board can be configured in single shunt and three-shunt and can support FOC and six-step algorithms in both configurations.

The Hall sensors connector and the phase sensing network present on-board allow to implement both sensor and sensorless algorithms for motion control.

The EVALSTDRIVE101 allows a full evaluation of the STDRIVE101 and its features, including the embedded comparator for overcurrent protection and the drain-source voltage sensing of each power MOSFET.

Product status link
EVALSTDRIVE101
STDRIVE101

1 Specifications

Table 1. EVALSTDRIVE101 - Specifications

Parameter	Value	
Supply voltage	Nominal	
	From 6 V to 75 V	
Maximum current	Continuous ⁽¹⁾	20 A _{rms}
	Peak (OC protection enabled)	35 A
	Peak (OC protection disabled)	45 A

1. Actual maximum current could be limited by power dissipation.

The schematic of the EVALSTDRIVE101 (from Figure 1 to Figure 5) and the Bill of material (Table 2) are reported below.

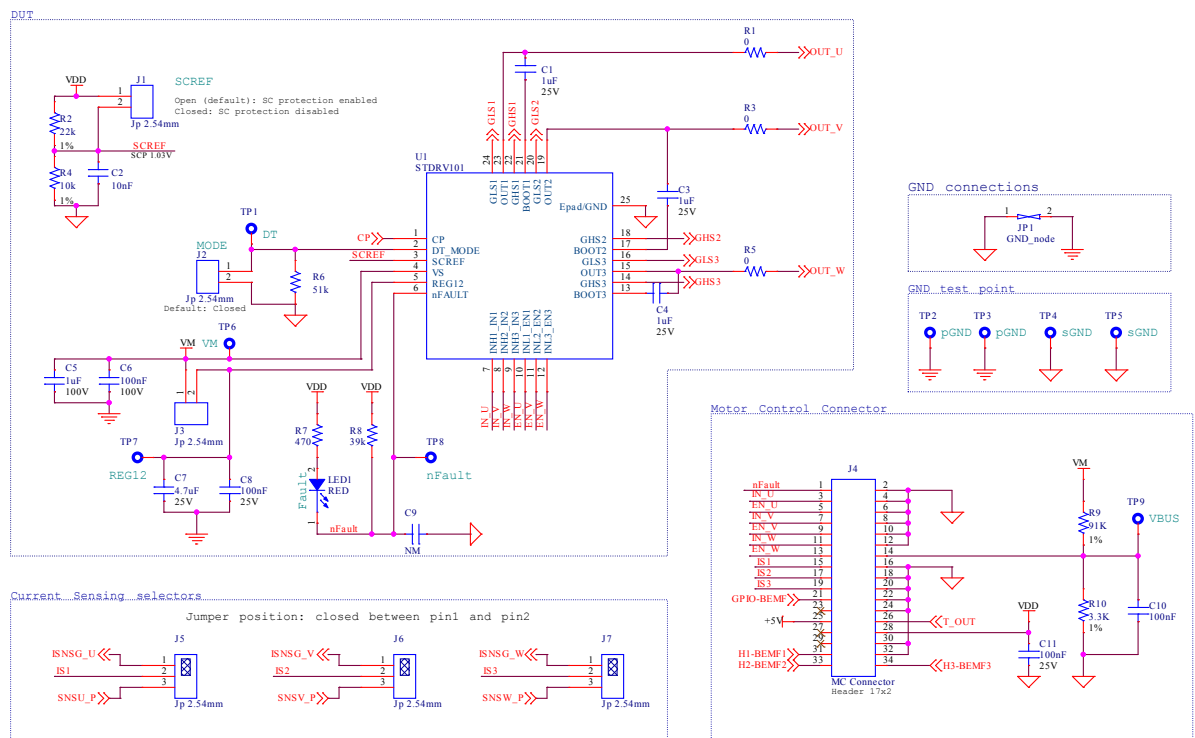
Figure 1. EVALSTDRIVE101 Schematic – Driver and MC connector


Figure 2. EVALSTDRIVE101 – Power Stage

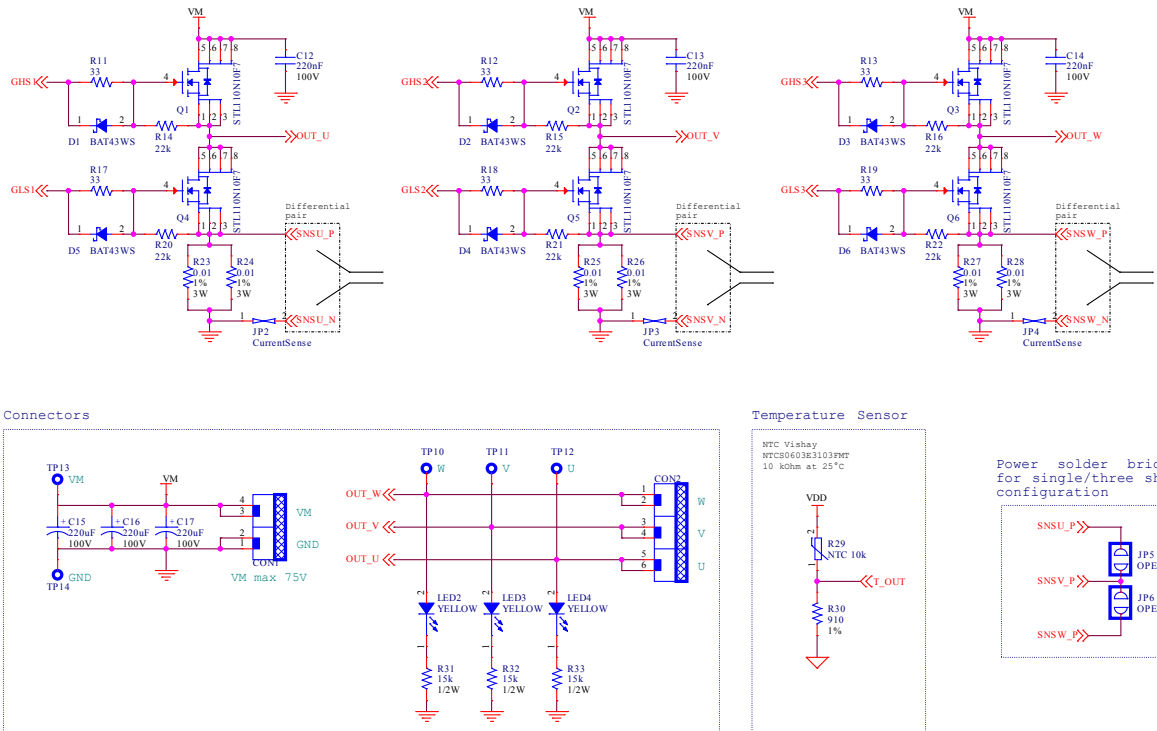


Figure 3. EVALSTDRIVE101 – Hall Sensors/BEMF Networks

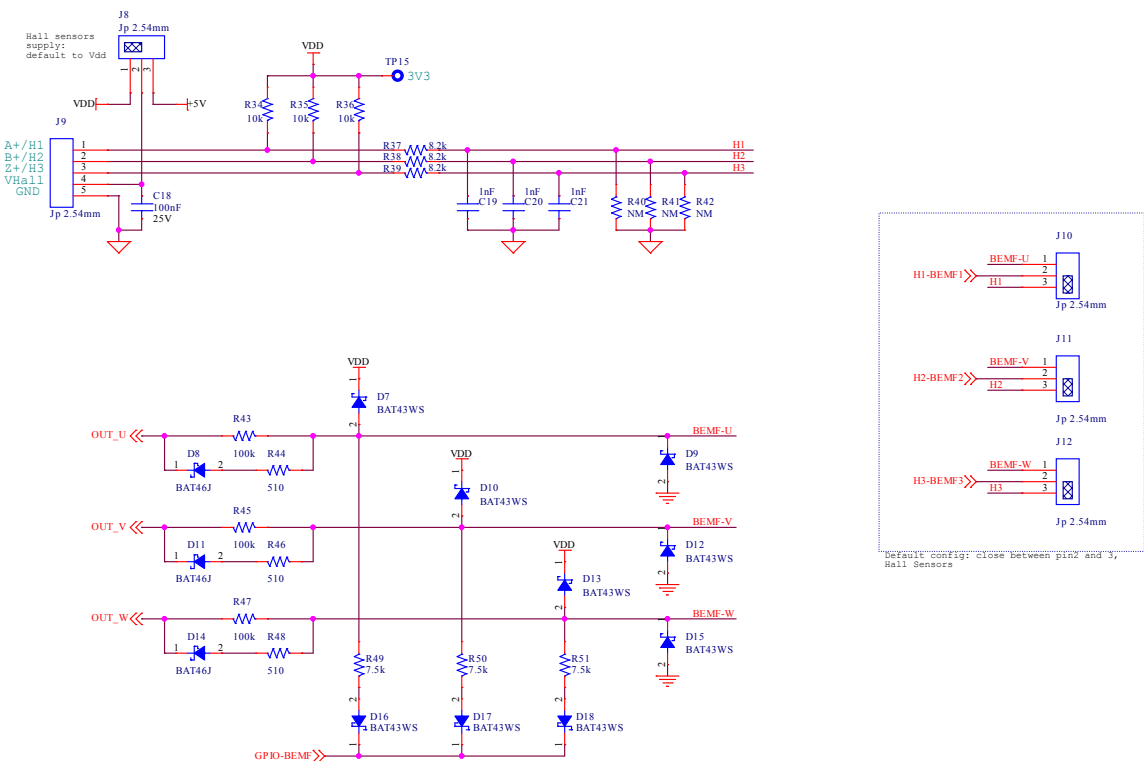
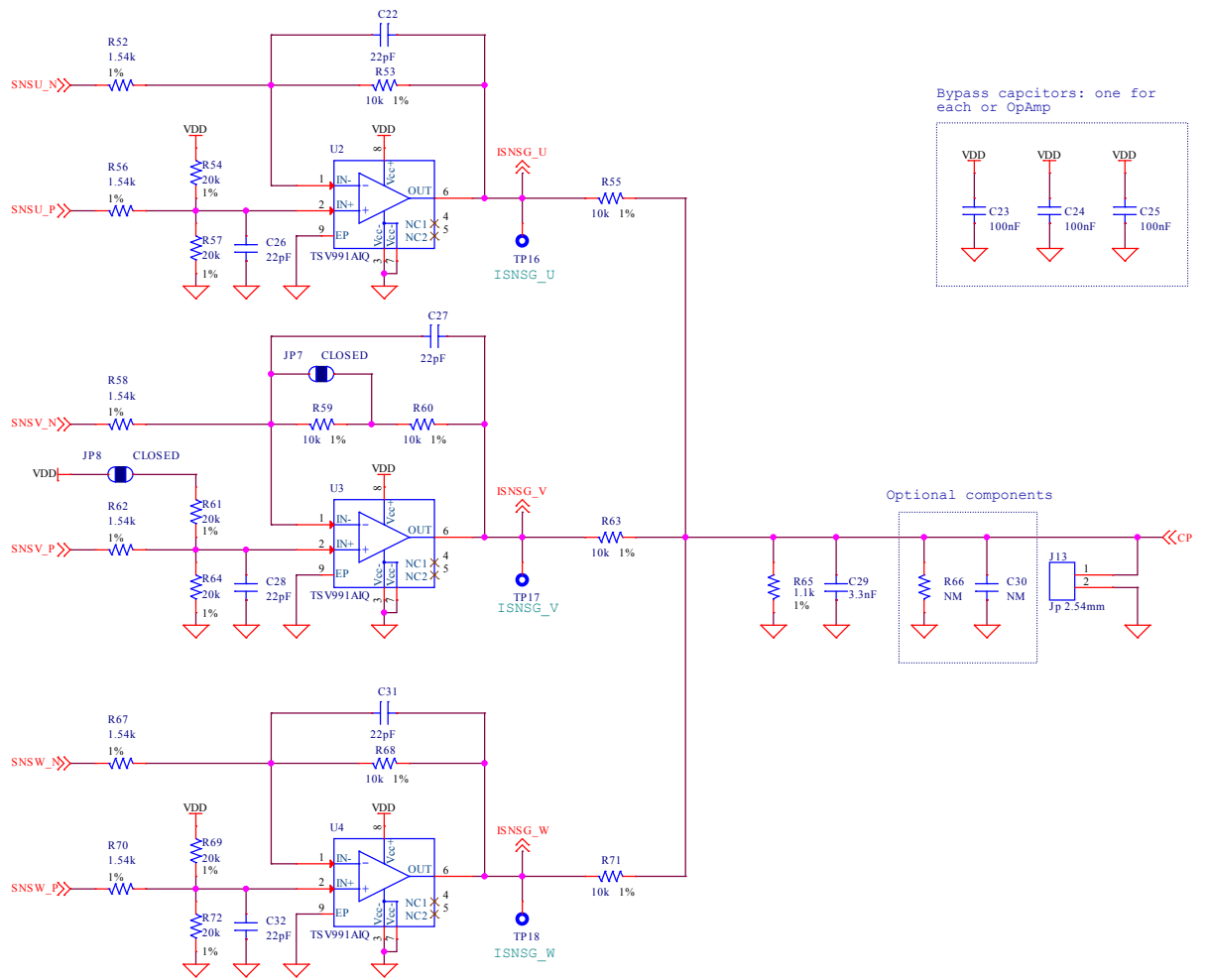


Figure 4. EVALSTDRIVE101 – Operational amplifiers



Bypass capacitors: one for each or OpAmp

Optional components

Figure 5. EVALSTDRIVE101 – Additional components

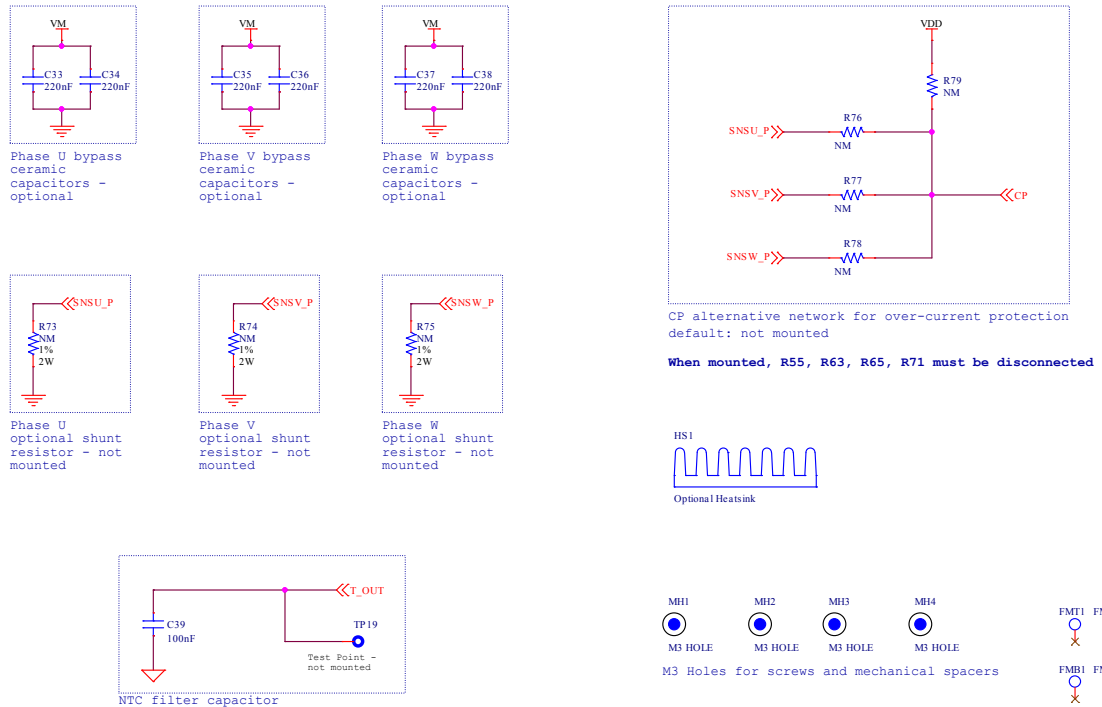


Table 2. EVALSTDRIVE101 – Bill of material

Item	Reference	Value	Part description	Package
1	CON1	2P Power connector	20 A power connector	Dual row, 2 poles, pitch 5 mm
2	CON2	3P Power connector	20 A power connector	Dual row, 3 poles, pitch 5 mm
3	C1, C3, C4	1 μ F, 25 V	SMT ceramic capacitor	Size 0805
4	C2	10 nF, 25 V	SMT ceramic capacitor	Size 0603
5	C5	1 μ F, 100 V	SMT ceramic capacitor	Size 0805
6	C6	100 nF, 100 V	SMT ceramic capacitor	Size 0805
7	C7	4.7 μ F, 25 V	SMT ceramic capacitor	Size 0805
8	C8, C10, C11, C18, C23, C24, C25, C39	100 nF, 25 V	SMT ceramic capacitor	Size 0603
9	C9, C30	Not Mounted	SMT ceramic capacitor	Size 0603
10	C12, C13, C14, C33, C34, C35, C36, C37, C38	220 nF, 100 V	SMT ceramic capacitor	Size 1206
11	C15, C16, C17	220 μ F, 100 V	TH electrolytic capacitor	Dia12.5mm x 25 mm
12	C19, C20, C21	1 nF, 50 V	SMT ceramic capacitor	Size 0603
13	C22, C26, C27, C28, C31, C32	22 pF, 50 V	SMT ceramic capacitor	Size 0603
14	C29	3.3 nF, 50 V	SMT ceramic capacitor	Size 0603

Item	Reference	Value	Part description	Package
15	D1, D2, D3, D4, D5, D6, D7, D9, D10, D12, D13, D15, D16, D17, D18	BAT43WS	SMT Schottky Diode	SOD-323
16	D8, D11, D14	BAT46J	100 V, small signal Schottky Diode	SOD-323
17	JP1		GND node	
18	JP2, JP3, JP4		Current sense node	
19	JP5, JP6	Default: open	Power solder bridge	
20	JP7, JP8	Default: closed	Solder bridge	
21	J1, J3, J13	Default: open	Jumper	1x2 Strip contact pitch 2.54 mm
22	J2	Default: closed	Jumper	1x2 Strip contact pitch 2.54 mm
23	J4	MC connector	Header vertical connector 2x17 poles	17x2 connector pitch 2.54 mm
24	J5, J6, J7, J8	Default: closed 1-2	Jumper	1x3 Strip contact pitch 2.54 mm
25	J10, J11, J12	Default: closed 2-3	Jumper	1x3 Strip contact pitch 2.54 mm
26	J9		Hall sensors connector	1x5 Strip contact pitch 2.54 mm
27	LED1	Red	CHIPLED 0805	Size 0805
28	LED2, LED3, LED4	Yellow	CHIPLED 0805	Size 0805
29	Q1, Q2, Q3, Q4, Q5, Q6	STL110N10F7	N-channel 100 V Power MOSFET	PowerFLAT™ 5x6
30	R1, R3, R5	0 Ω	SMT resistor	Size 0603
31	R2	22 kΩ, 1%	SMT resistor	Size 0603
32	R4, R34, R35, R36, R53, R55, R59, R60, R63, R68, R71	10 kΩ, 1%	SMT resistor	Size 0603
33	R6	51 kΩ	SMT resistor	Size 0603
34	R7	470 Ω	SMT resistor	Size 0603
35	R8	39 kΩ	SMT resistor	Size 0603
36	R9	91 kΩ, 1%	SMT resistor	Size 0603
37	R10	3.3 kΩ, 1%	SMT resistor	Size 0603
38	R11, R12, R13, R17, R18, R19	33 Ω	SMT resistor	Size 0603
39	R40, R41, R42, R66, R76, R77, R78, R79	Not mounted	SMT resistor	Size 0603
40	R14, R15, R16, R20, R21, R22	22 kΩ	SMT resistor	Size 0603
41	R23, R24, R25, R26, R27, R28	10 mΩ, 3 W, 1%	SMT resistor	Size 2512
42	R29	NTC -10 kΩ	SMT NTC resistor	Size 0603
43	R30	910 Ω	SMT resistor	Size 0603
44	R31, R32, R33	15 kΩ, 0.5 W	SMT resistor	Size 0805
45	R37, R38, R39	8.2 kΩ	SMT resistor	Size 0603

Item	Reference	Value	Part description	Package
46	R43, R45, R47	100 kΩ, 1%	SMT resistor	Size 0603
47	R44, R46, R48	510 Ω	SMT resistor	Size 0603
48	R49, R50, R51	7.5 kΩ, 1%	SMT resistor	Size 0603
49	R52, R56, R58, R62, R67, R70	1.54 kΩ, 1%	SMT resistor	Size 0603
50	R54, R57, R61, R64, R69, R72	20 kΩ, 1%	SMT resistor	Size 0603
51	R65	1.1 kΩ, 1%	SMT resistor	Size 0603
52	R73, R74, R75	Not mounted	SMT resistor	Size 2512
53	TP1, TP2, TP3, TP4, TP5, TP6, TP7, TP8, TP9, TP10, TP11, TP12, TP13, TP14, TP15, TP16, TP17, TP18	TP-SMD	SMT test point	SMD pad 3.43 x 1.78 mm
54	U1	STDRIVE101	Three-phase gate driver	QFN 4x4 24 L pitch 0,5 mm
55	U2, U3, U4	TSV991AIQ	Rail to rail input/output Operational Amplifier	DFN8 2x2
65	HS1		Heatsink, thermal conductive interposer and 4 x M3 screws	75 x 74.6 x 15 mm
66	MH1, MH2, MH3, MH4		4 x M3 screws and spacers	

2 Waste and recycling

The Evaluation Board is not to be disposed of as urban waste. At the end of its life cycle, differentiated waste collection must be followed. Consult local authorities for more information on the proper disposal channels and recycling centers. It is mandatory to collect separately the Demonstration Board and make sure it is delivered to the appropriate waste management and recycling centers. As of 15 August 2018, in all countries belonging to the European Union, the Demonstration Board is subject to the requirements of WEEE Directive **2012/19/EU**, and therefore it is forbidden to dispose of the Demonstration Board as undifferentiated waste or with other domestic waste. Incorrect disposal of the Demonstration Board may cause damage to the environment and may incur fines based on specific countries' rules, regulations, and laws.

Revision history

Table 3. Document revision history

Date	Version	Changes
21-Oct-2020	1	Initial release.

Contents

1	Specifications	2
2	Waste and recycling	8
	Revision history	9
	Contents	10
	List of tables	11
	List of figures.....	12

List of tables

Table 1.	EVALSTRIVE101 - Specifications	2
Table 2.	EVALSTRIVE101 – Bill of material	5
Table 3.	Document revision history	9

List of figures

Figure 1.	EVALSTDRIVE101 Schematic – Driver and MC connector	2
Figure 2.	EVALSTDRIVE101 – Power Stage	3
Figure 3.	EVALSTDRIVE101 – Hall Sensors/BEMF Networks	3
Figure 4.	EVALSTDRIVE101 – Operational amplifiers	4
Figure 5.	EVALSTDRIVE101 – Additional components	5

IMPORTANT NOTICE – PLEASE READ CAREFULLY

STMicroelectronics NV and its subsidiaries (“ST”) reserve the right to make changes, corrections, enhancements, modifications, and improvements to ST products and/or to this document at any time without notice. Purchasers should obtain the latest relevant information on ST products before placing orders. ST products are sold pursuant to ST’s terms and conditions of sale in place at the time of order acknowledgement.

Purchasers are solely responsible for the choice, selection, and use of ST products and ST assumes no liability for application assistance or the design of Purchasers’ products.

No license, express or implied, to any intellectual property right is granted by ST herein.

Resale of ST products with provisions different from the information set forth herein shall void any warranty granted by ST for such product.

ST and the ST logo are trademarks of ST. For additional information about ST trademarks, please refer to www.st.com/trademarks. All other product or service names are the property of their respective owners.

Information in this document supersedes and replaces information previously supplied in any prior versions of this document.

© 2020 STMicroelectronics – All rights reserved