

PART NUMBER	REVISION	DESCRIPTION	FEED TYPE
2151625-2	D	FINE CRIMP HEIGHT ADJUST	PNEUMATIC
7-2151625-2	D	PNEUMATIC AND CRIMP TOOLING KIT	PNEUMATIC
7-2151625-7	A	CRIMP TOOLING KIT	-

ATLANTIC VERSION TERMINATOR INTERFACE ADAPTER

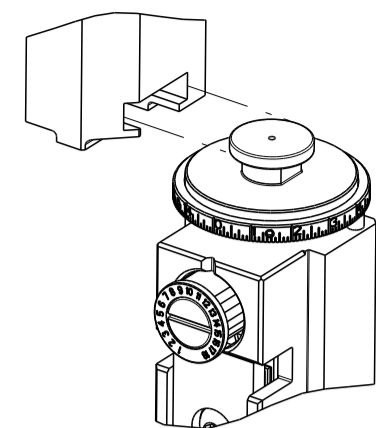

APPLICATOR DATA		
CRIMP	SIZE	TYPE
WIRE	5.33 mm [.210]	F
INSUL	8.71 mm [.343]	O

APPLICATOR INSTRUCTIONS 408-35042

TERMINAL DATA: FCI TERMINAL		FCI CRIMP SPECIFICATION	
TERMINAL NAME: 9.5 FEMALE TERMINAL			
WIRE STRIP LENGTH		INSULATION DIAMETER RANGE	
7.50-8.50 mm [.295-.335 IN]		Ø5.10-5.30 mm [.201-.209 IN]	
TERMINAL APPLICATION SPECIFICATION	9 084 16 00	-	-
TERMINALS APPLIED			
TE TERMINAL	FCI TERMINAL	TE SEAL	FCI SEAL
1949505-1	60070271	2113249-1	60993303
		2113249-2	60993304

WIRE SIZE	CRIMP HEIGHT mm [INCH]	CRIMP HEIGHT REFERENCE SETTING
10.00mm2	3.30 +/- 0.05 [.130 +/- .002]	4.6
8.00mm2	2.97 +/- 0.05 [.117 +/- .002]	9.3

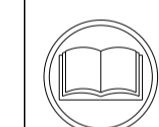

- 1 RECOMMENDED SPARE PARTS
- 2 REFER TO SUPPLIED INSTRUCTION SHEET FOR CLEANING, LUBRICATION AND STORAGE OF APPLICATOR.
- 3 APPLY PART NUMBER 2-23419-6 LOCTITE TO THREADS OF ITEM 242.
- 4 CRIMP HEIGHT REFERENCE SETTING WAS THE SETTING USED WHEN THE APPLICATOR WAS QUALIFIED AT THE FACTORY. ADJUSTMENT MAY BE NECESSARY WHEN RUNNING APPLICATOR IN THE FIELD.
- 5 TERMINAL PITCH NOT COMPATIBLE WITH MECHANICAL FEED.
- 6 THIS APPLICATOR APPLIES TERMINAL WITH A SEAL.
- 7 APPLY TORO-SEAL IN ALLEN SOCKET TO FILL HOLE AFTER FLAT HD HAS BEEN ADJUSTED TO CORRECT HEIGHT AT QUALIFICATION. APPLY #1-23419-5 LOC-TITE TO THREADS.
- 8 CUT TO LENGTH AT ASSEMBLY.
- 9. UNLESS SPECIFIED OTHERWISE TORQUE VALUES SHALL BE USED PER DOCUMENT, 101-35000.

***WARNING**
ON INSTALLATION, SET WIRE DISC TO CRIMP HEIGHT REFERENCE SETTING FOR LARGEST WIRE SIZE. CRIMP HEIGHT REFERENCE SETTINGS GREATER THAN THE VALUE SHOWN MAY CAUSE DAMAGE TO THE CRIMP TOOLING, REFER TO THE INSTRUCTION SHEET FOR PROPER SETUP AND ADJUSTMENTS.

ATLANTIC VERSION
Shown on sheets 1 of 4 & 2 of 4
(Pacific version shown on sheets 3 of 4 & 4 of 4)

LOC	DIST	REVISIONS					
A	66	P	LTN	DESCRIPTION	DATE	OWN	APVD
		A		RELEASED	30NOV2012	RK	TE
		B		ECR-13-012621	09AUG2013	YY	UG
		C		ECR-23-175045	11MAY2023	ROY	TIM
		D		ECR-23-179843	29JUN2023	JWC	TIM

-	1	1	1803945-4	TONKER	300
-	1	1	22278-9	SPRING, COMPRESSION	299
-	2	2	4-18032-3	SCR, SET, FLT PNT, M3 X 6.0	298
-	1	1	1803944-1	SPACER, TONKER	297
-	1	1	2-455888-2	SPACER, CRIMPER	259
-	1	1	2119641-1	FEED CAM, AIR FEED	248
-	1	1	2119082-8	CAM, SWAIL, INSULATION ADJUSTMENT	244
-	1	1	2079764-1	WASHER, WAVE SPRING, CREST-TO-CREST	243
-	1	1	2119083-1	RETAINER, INSULATION DIAL	242
-	1	1	7-18023-7	SCR, SKT HD CAP M3 X 4.0	241
-	1	1	2844940-8	AIR FEED MODULE	238
-	REF	REF	994970-2	COUNTER, MAGNETIC	164
-	1	1	1-22281-8	SPRING, COMPRESSION	121
-	1	1	1-18028-2	WASHER, FLAT, REG M4	119
-	1	1	2-690438-2	FRONT STRIP GUIDE	96
-	2	2	2168083-1	SCR, SKT HD CAP, RoHS, M3 X 8.0	95
-	1	1	2168083-6	SCR, SKT HD CAP, RoHS, M5 X 65	93
-	1	1	1-455888-6	SPACER, CRIMPER	82
-	1	1	1803607-3	DOCUMENTATION PACKAGE	71
-	1	1	2119740-1	TAG, IDENTIFICATION	67
-	2	2	2168078-1	SCREW, DRIVE, RH, RoHS, 2 x .188	66
-	2	2	2-18032-5	SCR, SET, FLT PNT, M5 X 20.0	61
-	1	1	2168083-2	SCR, SKT HD CAP, RoHS, M4 X 8.0	60
-	1	1	5-18022-5	SCR, HEX HD CAP, M4 X 6.0	59
-	1	1	18023-6	SCR, SKT HD CAP M3 X 16.0	57
-	1	1	1338683-8	FEED PAWL	56
-	4	4	2168083-3	SCR, SKT HD CAP, RoHS, M4 X 12.0	54
-	2	2	2168083-3	SCR, SKT HD CAP, RoHS, M4 X 12.0	53
-	1	1	18023-9	SCR, SKT HD CAP M4 X 6.0	49
-	1	1	1-1803583-7	APPLICATOR BASIC ASSEMBLY, SF	46
-	1	1	1803515-2	RAM ASSEMBLY, SF ATLANTIC	44
-	1	1	1-2079383-5	SCR, BHSC, RoHS (M8 X 40)	41
-	1	1	3-1752356-3	SUPPORT, TERMINAL	34
-	2	2	1-2079383-3	SCR, BHSC, RoHS (M4 X 25)	33
-	2	2	3-2844962-7	SPACER, CYLINDRICAL, STRIP GUIDE	30
-	1	1	2844938-9	PLATE, STRIP GUIDE	29
-	1	1	1-455888-0	SPACER, CRIMPER	28
-	2	2	22283-1	SPRING, COMPRESSION	27
-	1	1	356835-1	LEVER, DRAG RELEASE	26
-	1	1	240792-1	DRAG, TERMINAL	25
-	1	1	1320928-4	STRIP GUIDE	24
-	1	1	980371-4	SCR, SKT HD SHLDR 5.0 DIA X 6.0	23
-	1	1	2168083-2	SCR, SKT HD CAP, RoHS, M4 X 8.0	21
-	1	1	1-18028-2	WASHER, FLAT, REG M4	20
-	1	1	2119533-5	STRIPPER, SIDE FEED	19
-	1	1	2119806-1	INSERT, SHEAR	13
-	1	1	4-22280-7	SPRING, COMPRESSION	12
-	1	1	1-356885-3	STOP, SHEAR	11
-	1	1	2119805-7	SHEAR HOLDER, FRONT	10
-	1	1	318059-9	FLOATING SHEAR, FRONT	9
-	1	2	1633930-5	ANVIL, COMBINATION	8
-	-	-	-	-	7
-	-	-	-	-	6
-	1	1	1803080-1	DEPRESSOR, SHEAR	5
-	1	1	4-238011-5	BLOCK, CRIMPER SPACER	4
-	1	2	4-2119784-8	CRIMPER, INSULATION O PREMIUM	3
-	1	1	1-455888-9	SPACER, CRIMPER	2
-	1	2	4-1673600-4	CRIMPER, WIRE	1

DIMENSIONS:		TOLERANCES UNLESS OTHERWISE SPECIFIED:		MATERIAL:		FINISH:		WEIGHT:		SCALE:	
mm	0 PLC ±	1 PLC ±	2 PLC ±	3 PLC ±	4 PLC ±	ANGLES	FINISH	Customer Accessible Production Drawing	SCALE	1:2	SHEET 1 of 4

STE TE Connectivity
Harrisburg, PA 17105-3608

NAME: Ocean Side Feed Applicator

SIZE: A1 CAGE CODE: 00779 DRAWING NO: 2151625

RESTRICTED TO: D

LOC	DIST	REVISIONS					
A	66	P	LTN	DESCRIPTION	DATE	OWN	APVD
		-		SEE SHEET 1	-	-	-

FEED TYPE

PNEUMATIC

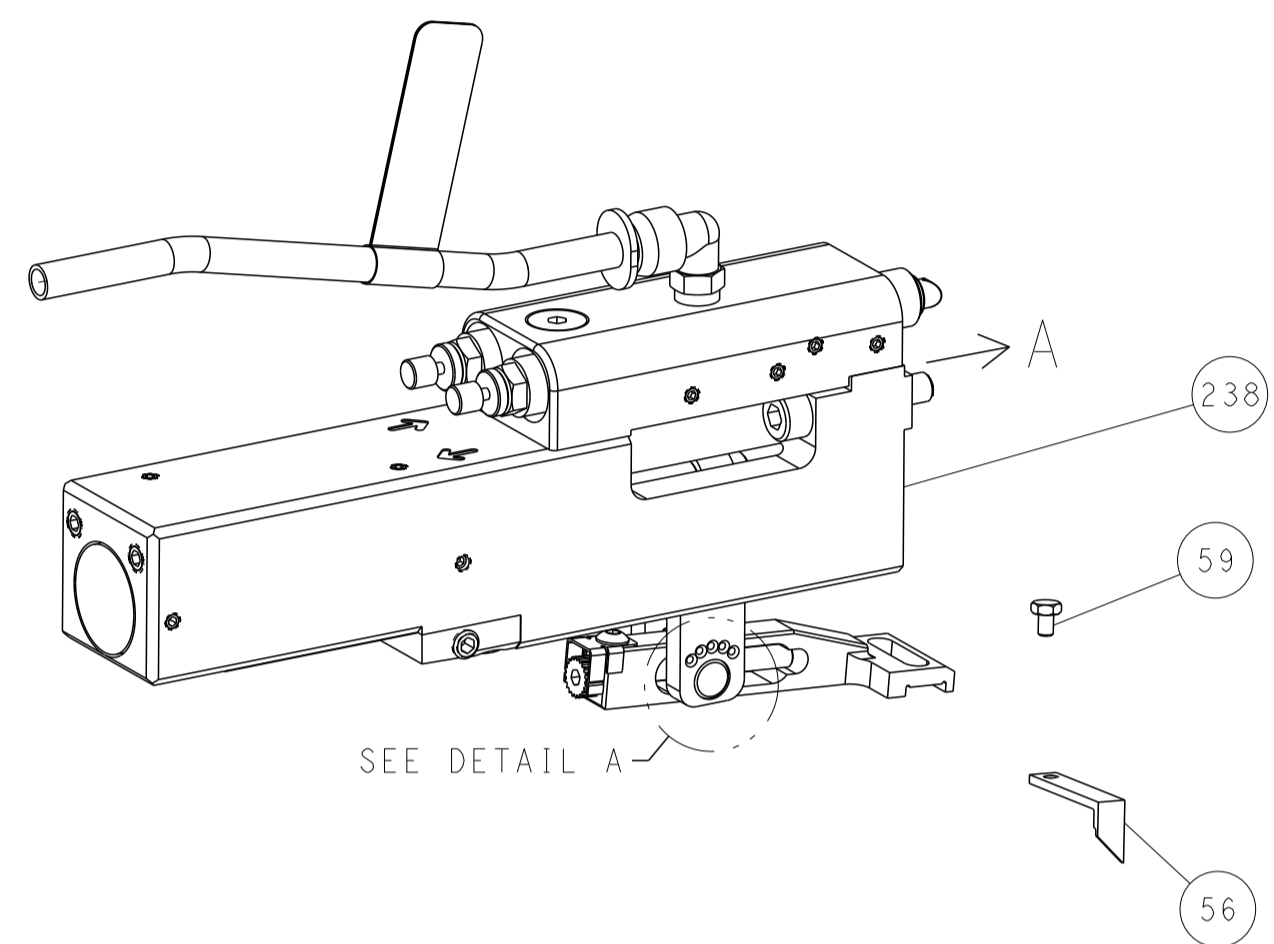

FEED SPRING SETTING POSITION
(SHOWN FROM REAR SIDE)

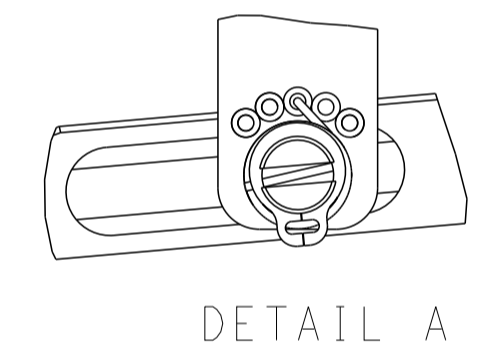

DETAIL A

CAM POSITION

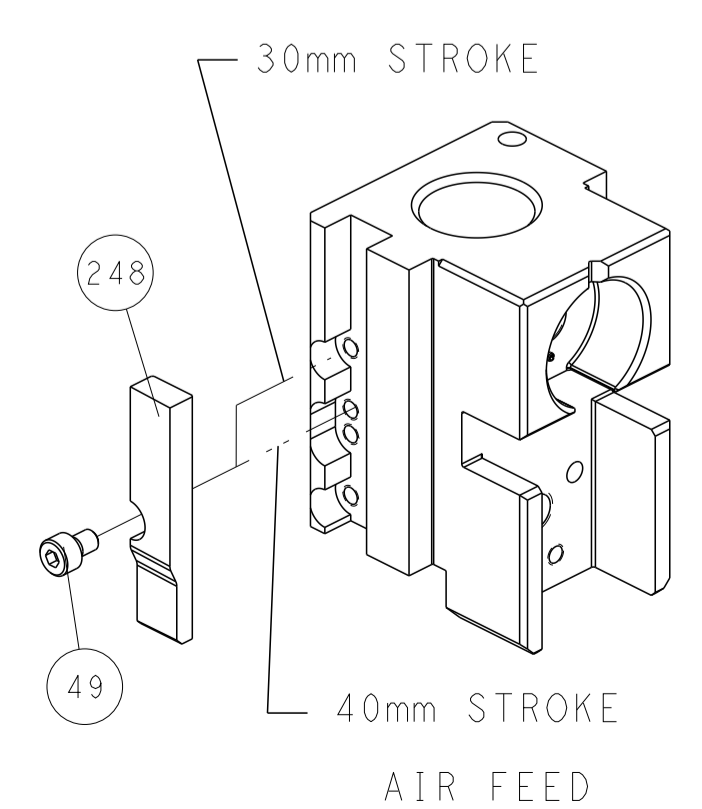

AIR FEED

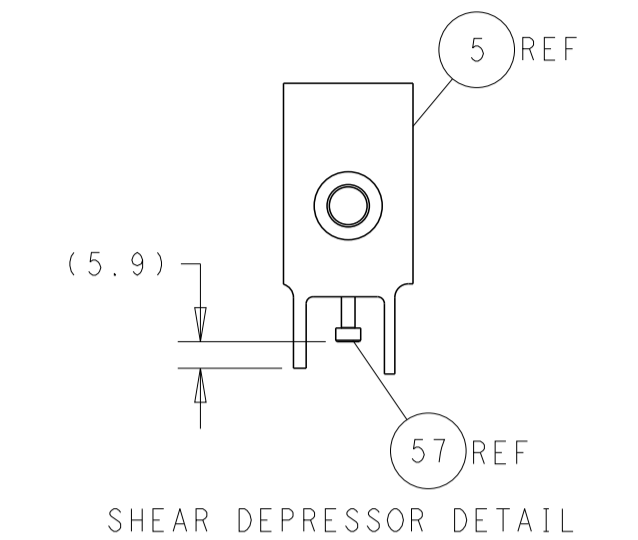
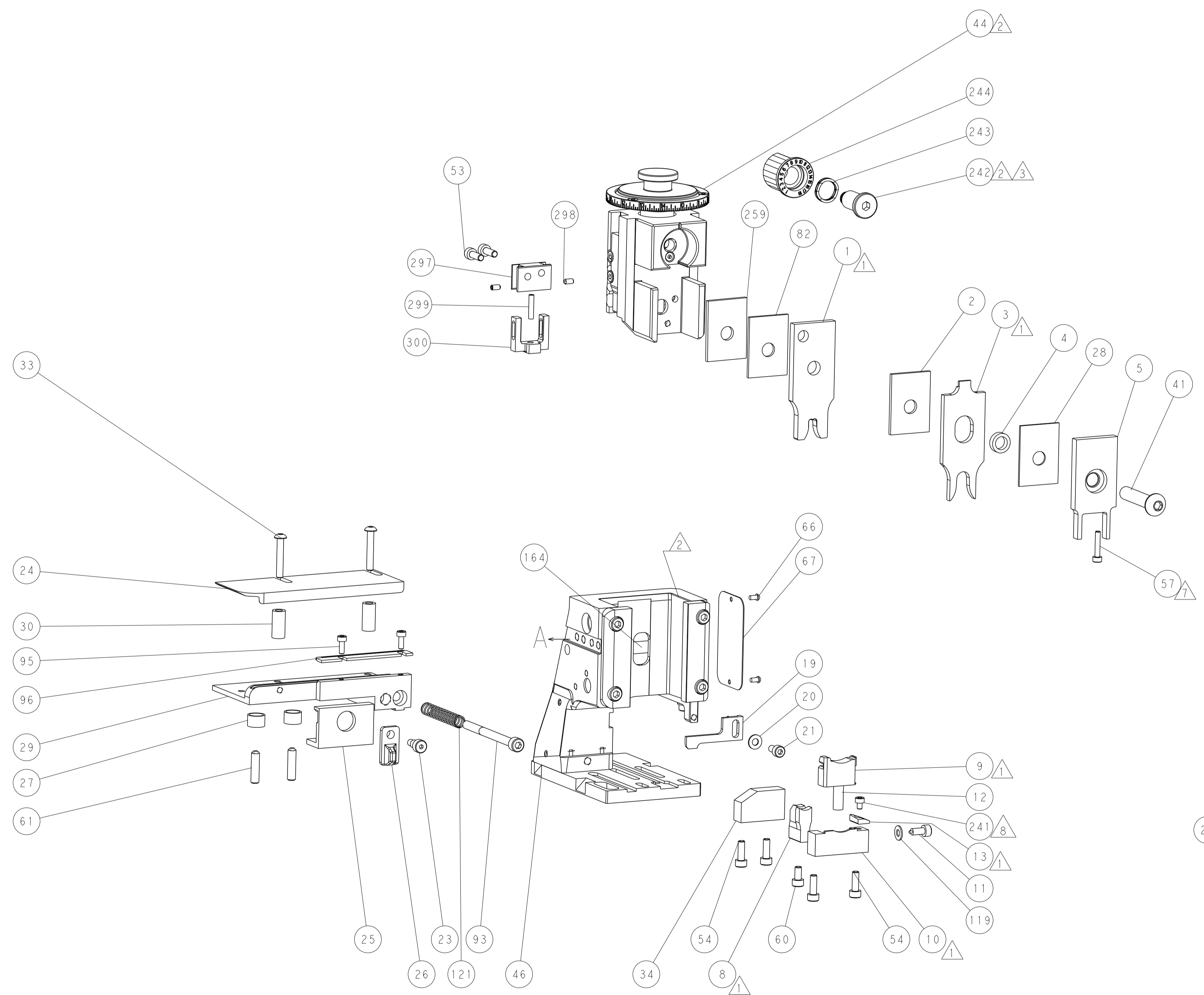

SHEAR DEPRESSOR DETAIL

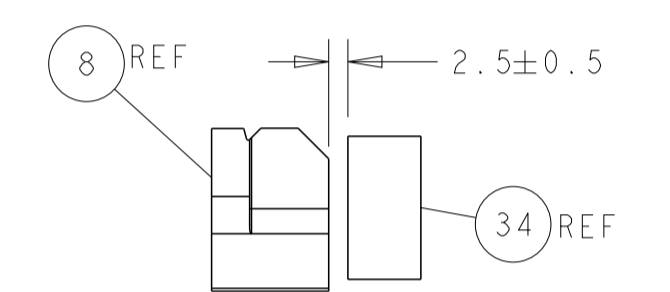

TERMINAL SUPPORT LOCATION

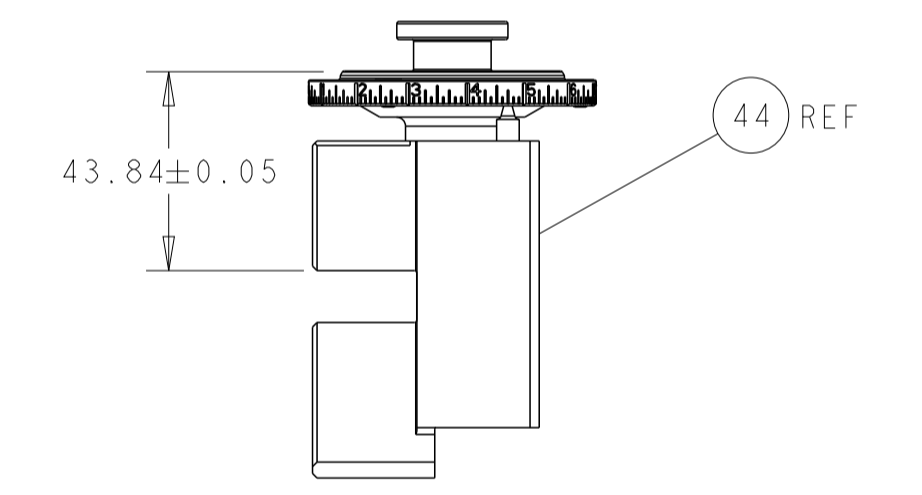

RAM SET-UP

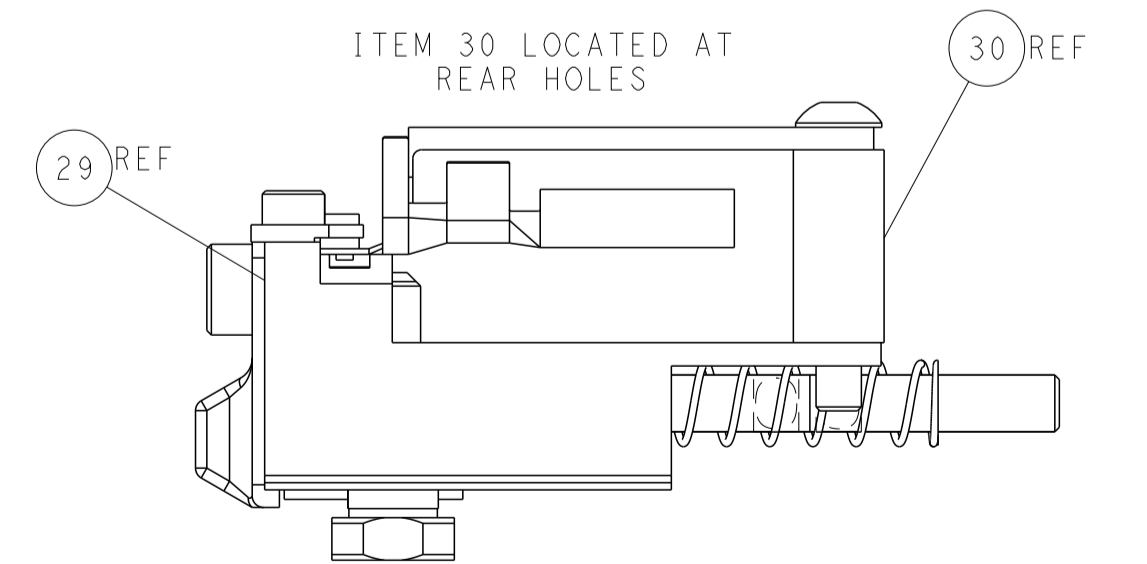

FEED TRACK POSITION
GUIDE BY INSULATION BARREL

ATLANTIC VERSION
 Shown on sheets 1 of 4 & 2 of 4
 (Pacific version shown on sheets 3 of 4 & 4 of 4)

<small>THIS DRAWING IS UNPUBLISHED. RELEASED FOR PUBLICATION. ALL RIGHTS RESERVED. © 2000 BY TYCO ELECTRONICS CORPORATION.</small>		DWN: R. KNEPPER 03MAY2012 CHK: T. ELBIN 03MAY2012 APVD: M. CLIFFORD 03MAY2012	TE Connectivity Harrisburg, PA 17105-3608
DIMENSIONS: mm TOLERANCES UNLESS OTHERWISE SPECIFIED: 0 PLC ± 1 PLC ± 2 PLC ± 3 PLC ± 4 PLC ± ANGLES ± FINISH		NAME: Ocean Side Feed Applicator PRODUCT SPEC: APPLICATION SPEC: WEIGHT:	SIZE: A1 CAGE CODE: 00779 DRAWING NO: 2151625 SCALE: 1:2 SHEET: 2 OF 4 REV: D
MATERIAL:		RESTRICTED TO:	Customer Accessible Production Drawing

