

THIS DRAWING IS UNPUBLISHED. RELEASED FOR PUBLICATION .19
 BY AMP INCORPORATED. ALL RIGHTS RESERVED.

LOC	DIST	REVISIONS			
P	LTR	DESCRIPTION	DATE	DWN	APVD
FT	0	A	RELEASED PER ECN 063B-0027-01	24JAN01	SU MC

- 1. RECEPTACLE IS LOADED WITH FOUR SIZE 16, HIGH CURRENT POSTED CONTACTS.
- 2. FINISH: SILVER PLATE .0002-.0004 IN PER AMP SPEC 112-32-1 OVER .00005-.00015 IN NICKEL PER AMP SPEC 112-25-2.

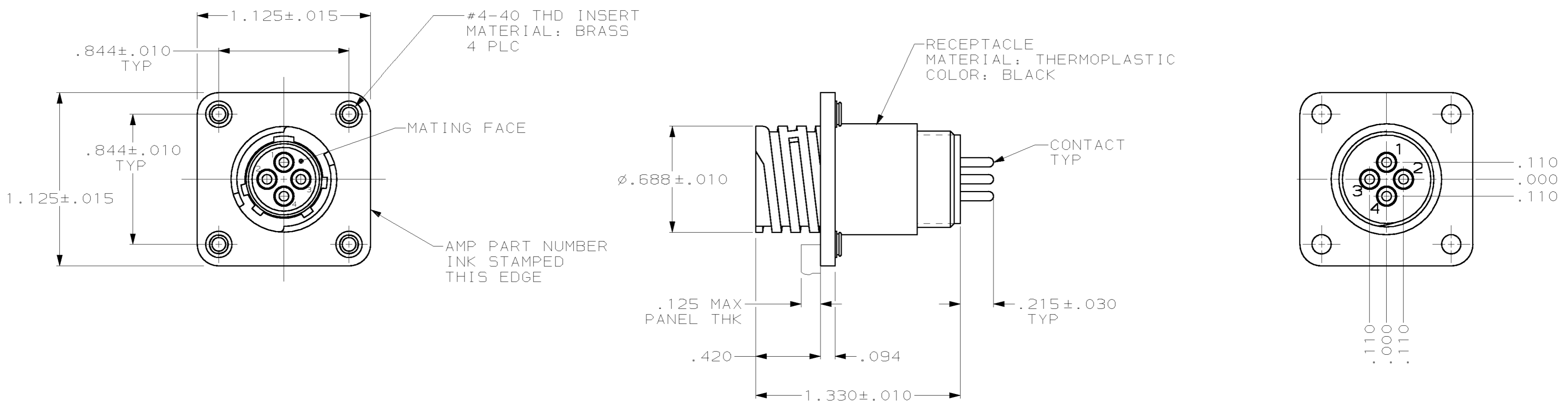

796764-1
PART NUMBER

THIS DRAWING IS A CONTROLLED DOCUMENT.		DWN S.URICH 24JAN01	AMP Incorporated Harrisburg, PA 17105-3608	
DIMENSIONS: INCHES		CHK M.CHACKO 24JAN01	NAME RECEPTACLE ASSEMBLY, POSTED, STD SEX, SERIES 1, 11-4, CPC	
TOLERANCES UNLESS OTHERWISE SPECIFIED: 0 PLC ±- 1 PLC ±- 2 PLC ±- 3 PLC ±.005 4 PLC ±- ANGLES ±- FINISH		APVD S.WELDON 24JAN01	PRODUCT SPEC - APPLICATION SPEC -	
MATERIAL SEE CALLOUT		WEIGHT -	SIZE A2	RESTRICTED TO -
CONTACT 2		CAGE CODE 00779	DRAWING NO 796764	SCALE 2:1
CUSTOMER DRAWING		SHEET 1	OF 1	REV A

796764