

## SPECIFICATION

- Part No. : **DBP.2450.X.A.30**
- Description : Dielectric Band Pass Filter for 2450MHz  
Bandwidth 100MHz
- Features : Center Frequency 2450MHz  
Supports ISM 2450MHz  
Low Insertion Loss  
High Ultimate Attenuation  
Dims: 7.2\*6.3\*3mm



## 1. Introduction

Taoglas are utilizing their deep understanding of the RF component design and manufacturing process to provide high-quality, small-form-factor, cost-effective and easy to implement RF filters. The Taoglas Filters Division will feature a range of off-the-shelf filters for a variety of applications, including filters for emerging license free bands used for IoT and for GPS L1/L2 and L1/L5 applications. We can also work with customers to develop bespoke filter solutions.

Taoglas dielectric filters are designed to be used in wireless transmitters or receivers. These filters are designed to protect the LNA from noisy out of band emissions originated from nearby transmitters that can overdrive, or even damage your LNA. Overdriving the LNA results in non-linear distortion which negatively impacts the sensitivity of your receiver.

By selecting the proper Taoglas filter you can eliminate unnecessary out of band noise while maintaining minimal in-band insertion loss. The filter is manufactured as a single ceramic block [monoblock] which provides high reliability, low insertion loss and high attenuation in a simple compact SMD package.

The DBP.2450.X.A.30 is a standard Taoglas product but can be customized for specific customer needs. For more information please contact your regional sales office.

## 2. Specification

ELECTRICAL	
Centre Frequency (Fo)	2450MHz
3dB Bandwidth	100MHz
Insertion Loss	2.0 dB max
Return Loss	< -10 dB
Attenuation	> 40.0 dB @ 0 ~ 2000MHz > 30.0 dB @ 2000MHz ~ 2200MHz > 25.0 dB @ 2700MHz ~ 2900MHz > 15.0 dB @ 2900MHz ~ 5000MHz
In/Out Impedance	50 Ω
Power Dissipation	1.0 W min.
MECHANICAL	
Dimension	7.2*6.3*3mm (L*W*H)
Material	Ceramic
Finish	Ag plated
ENVIRONMENTAL	
Operating Temperature	-40°C to 85°C
Storage Temperature	-40°C to 85°C
Moisture Sensitivity Level (MSL)	3 (168 Hours)

### 3. Characteristics Curve

#### 3.1. Pass Band Return & Insertion Loss

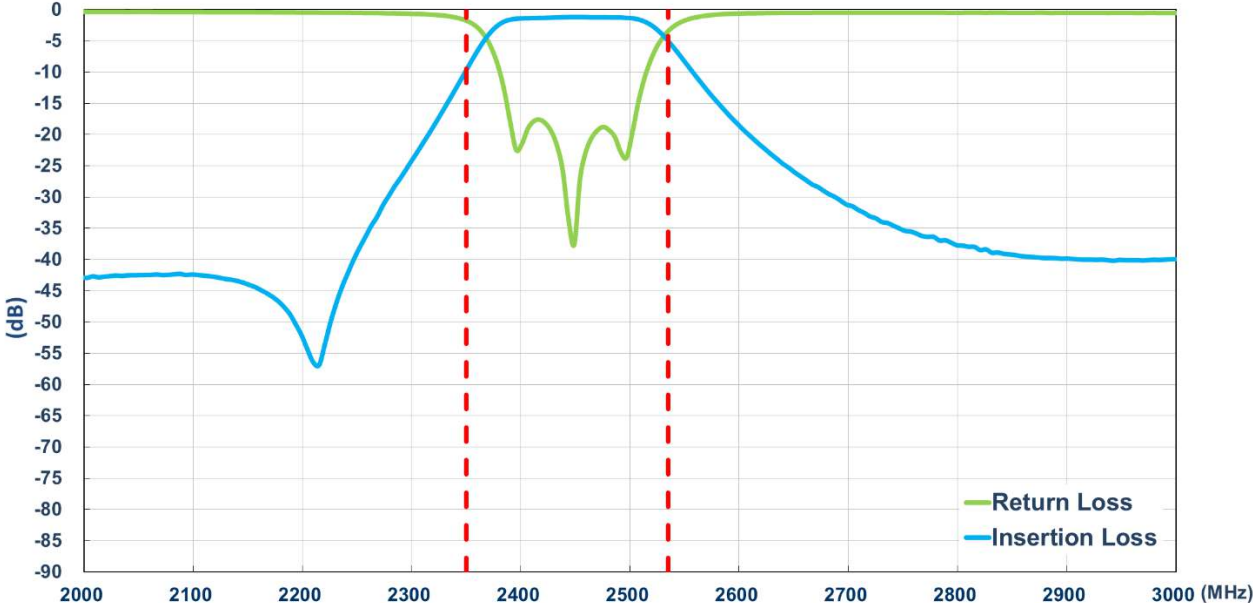

#### 3.2. Out-Of-Band Attenuation

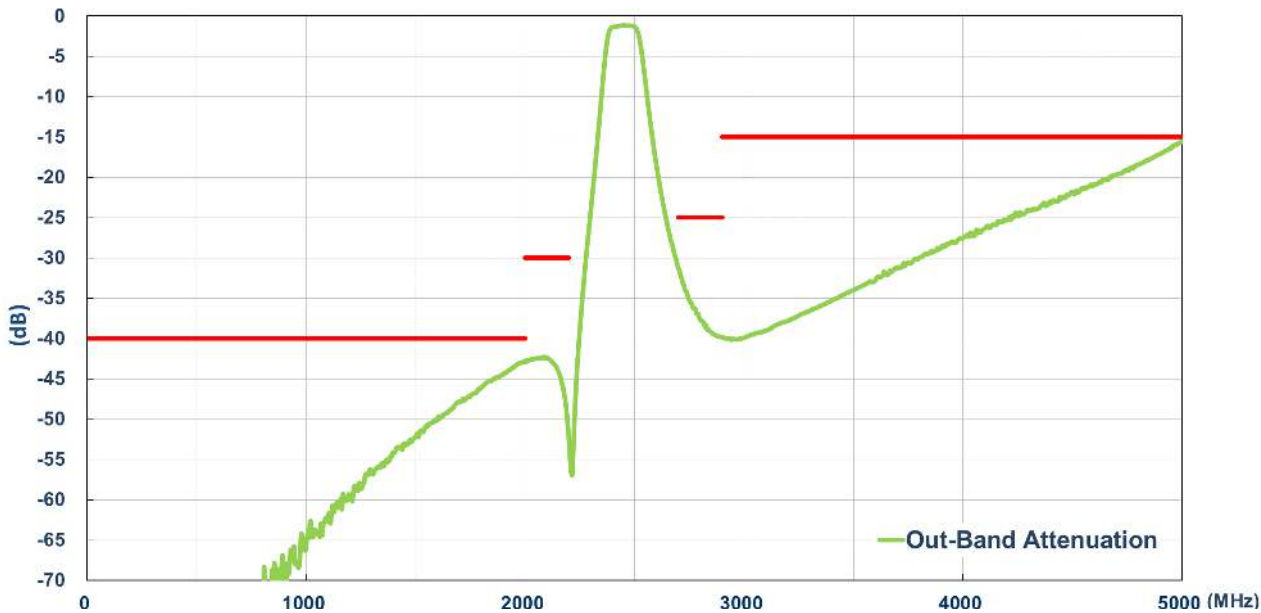

## 4. Mechanical Drawings (Unit: mm)

### 4.1. Antenna Drawing

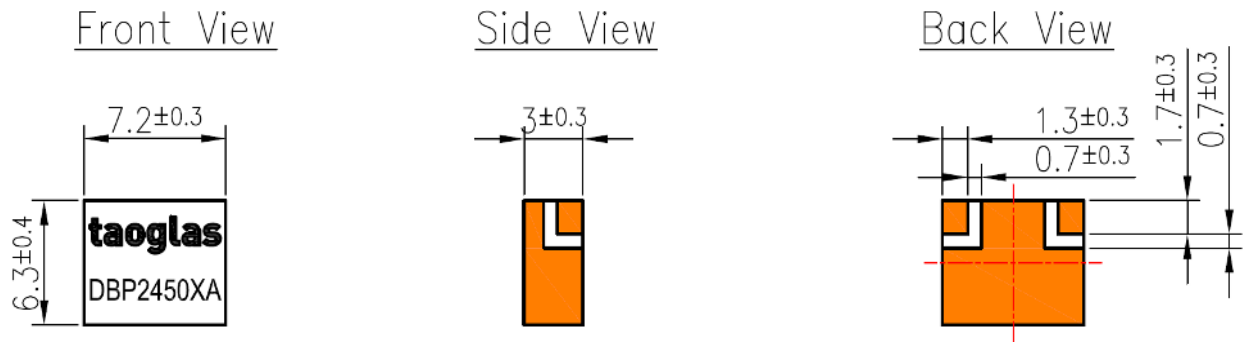

## 4.2. Recommended PCB Layout

### 4.2.1. Top Copper

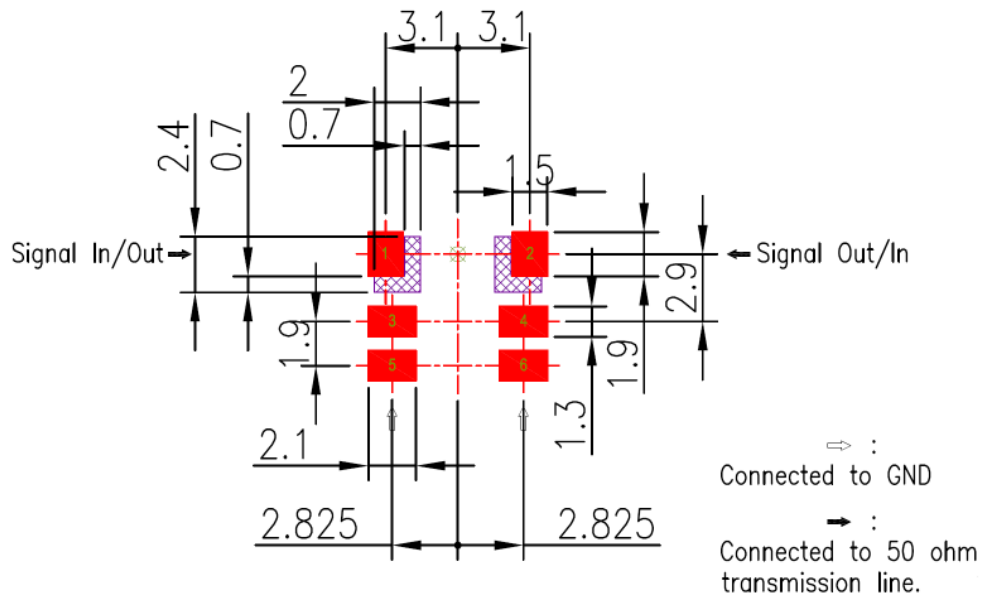

### 4.2.2. Top Solder Paste

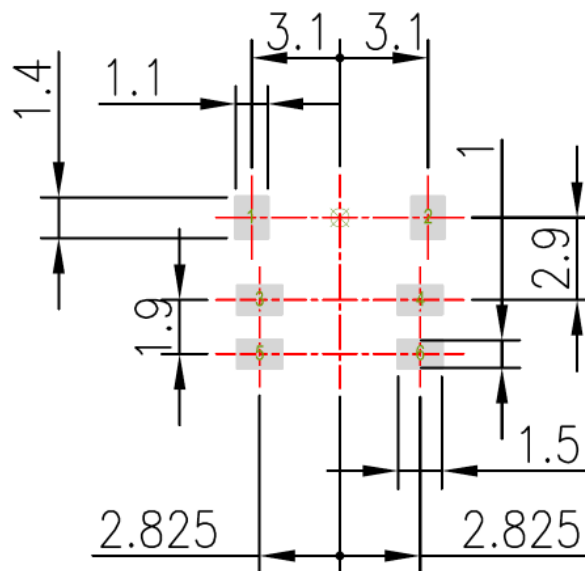

**NOTE:**

- 1. Ag Plated area
- 2. Solder Mask area
- 3. Copper area
- 4. Paste area
- 5. Copper Keepout Area



- 6. Any vias in pads should be either filled or tented to prevent solder from wicking away from the pad during reflow.
- 7. The dimension tolerances should follow standard PCB manufacturing guidelines

### 4.2.3. Top Solder Mask

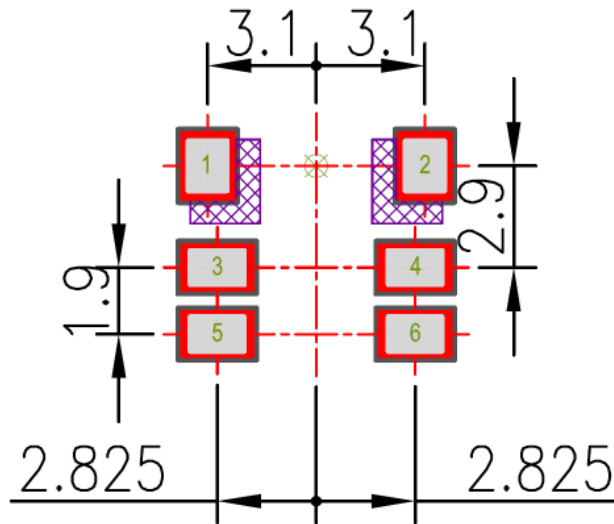

### 4.2.4. Composite Diagram

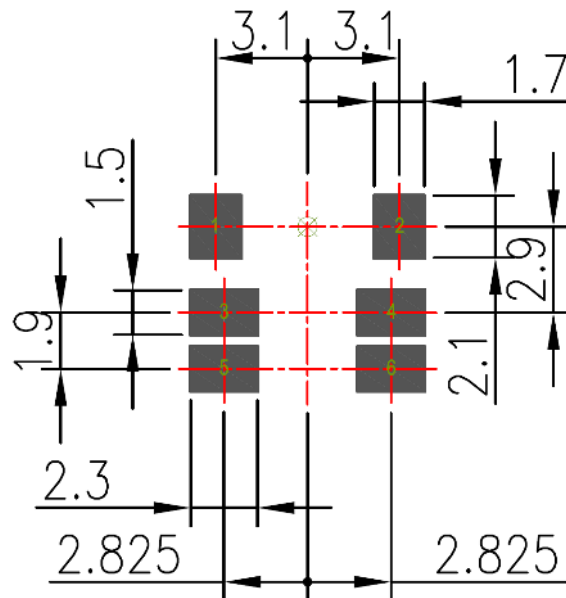

**NOTE:**

- 1. Ag Plated area
- 2. Solder Mask area
- 3. Copper area
- 4. Paste area
- 5. Copper Keepout Area



- 6. Any vias in pads should be either filled or tented to prevent solder from wicking away from the pad during reflow.
- 7. The dimension tolerances should follow standard PCB manufacturing guidelines

**4.3. Evaluation Board**

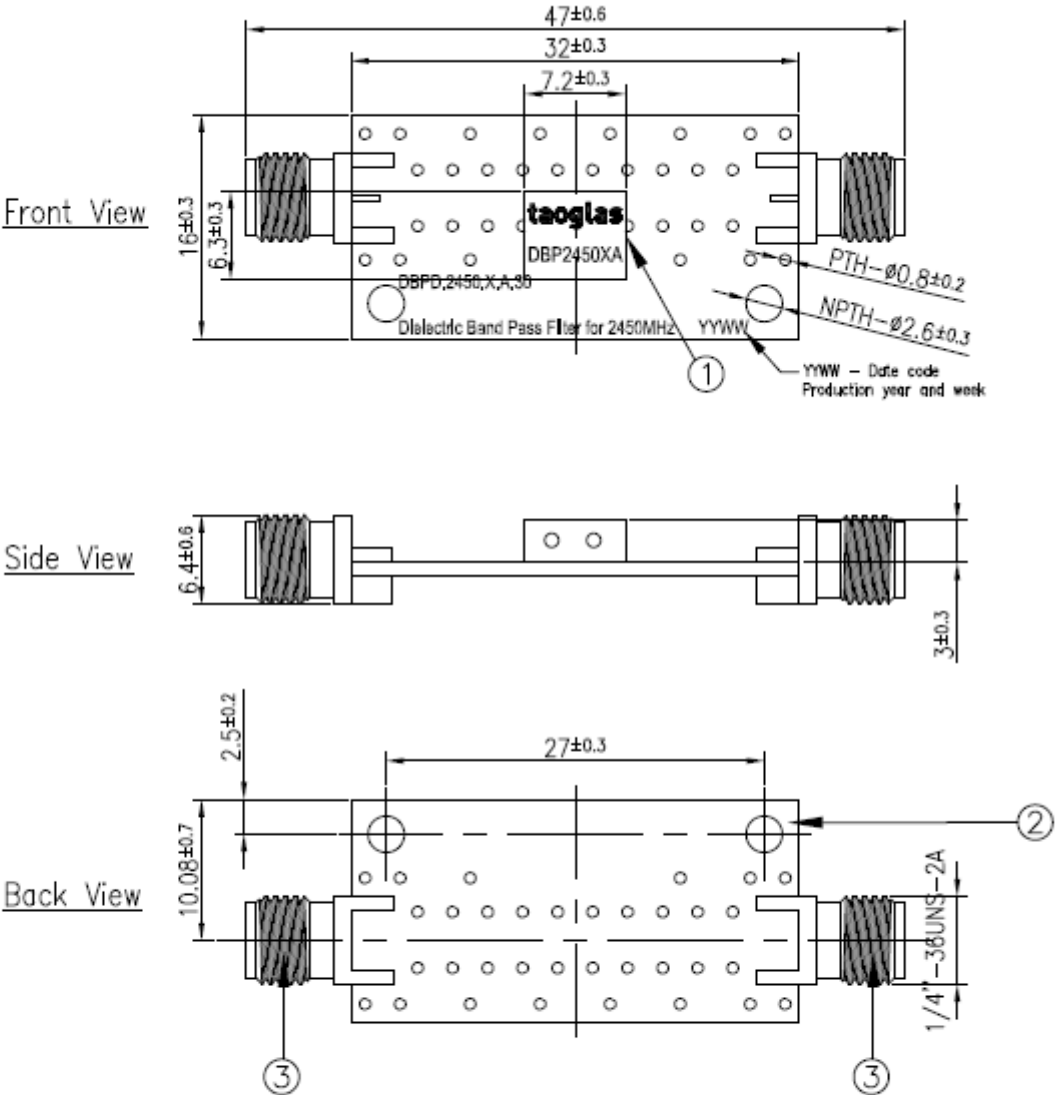

NOTE:  
1.All material must be RoHS compliant.

	Name	Material	Finish	QTY
1	Filter	Ceramic	Clear	1
2	PCB	Composite 1.0t	Black	1
3	SMA(F) ST	Brass	Au Plated	2



## 5. Recommended Reflow Soldering Profile

Phase	Profile Features	Maximum
Preheat	Temperature Min	150°C
	Temperature Max	180°C
	Duration	60-120 sec
Ramp-Up	Avg. Ramp up rate	3°C/sec (max)
Reflow	Temperature	220°C
	Duration	30-40 sec
Peak	Temperature	265°C
	Duration	5 sec Max
Ramp Down	Avg. Ramp down rate	3°C/sec (max)

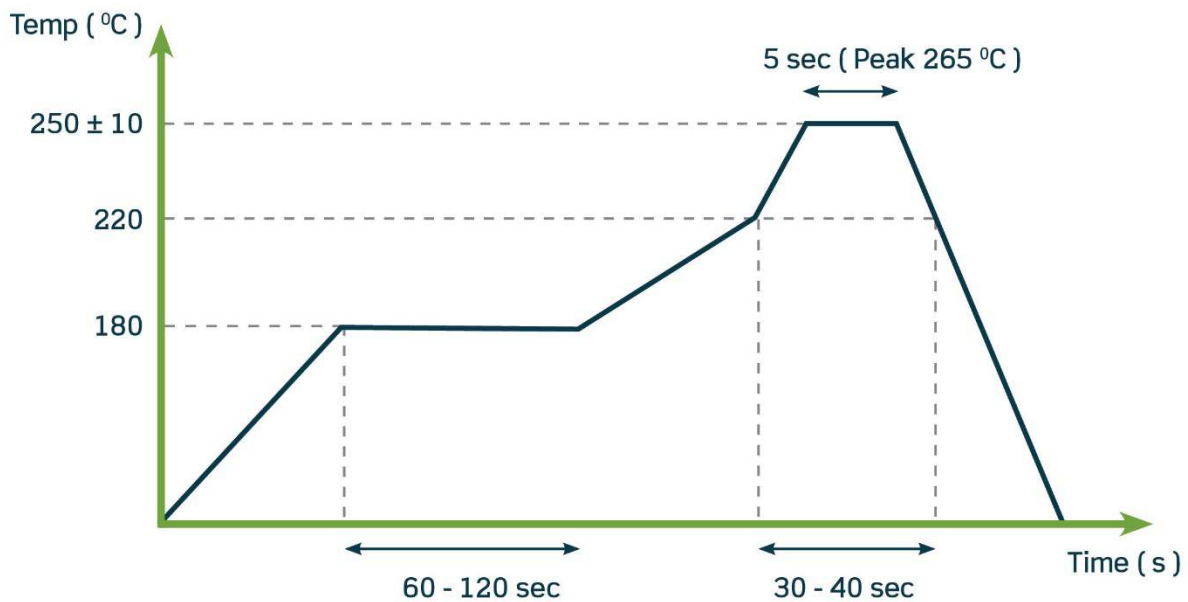

# 6. Packaging

1250 pc DBP.2450.X.A.30  
1 reel per small inner box  
Dimensions - 330\*16.4mm  
Weight - 1080g

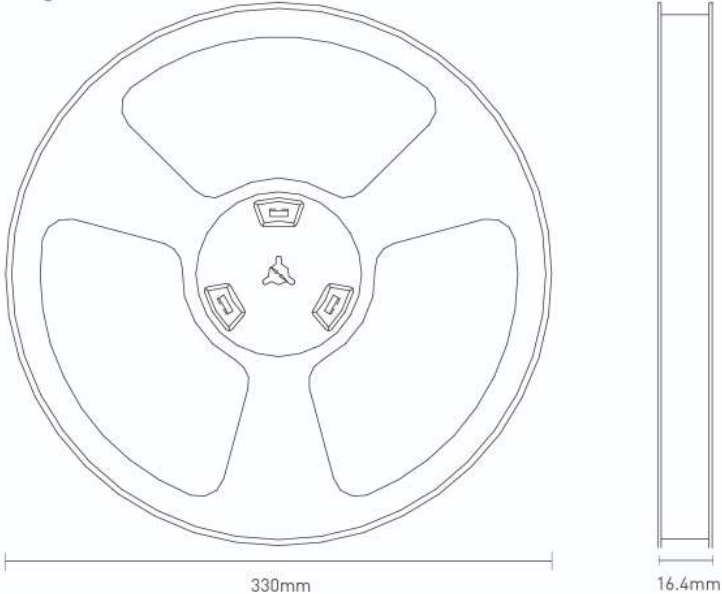

2500 pc DBP.2450.X.A.30  
2 reel in small inner box  
Dimensions - 340\*340\*51  
Weight - 2.28Kg

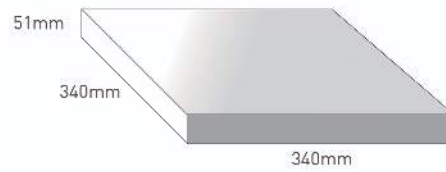

4 inner boxes / 10000 pcs in one carton  
Carton Dimensions - 210\*345\*360mm  
Weight -9.6Kg

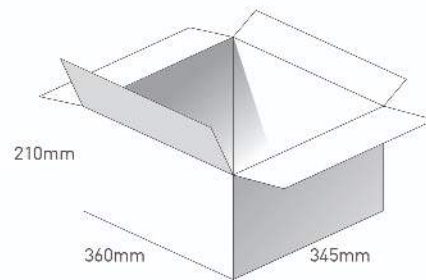

Pallet Dimensions 1100\*1100\*1280mm  
24 Cartons per Pallet  
6 Cartons per layer  
4 Layers

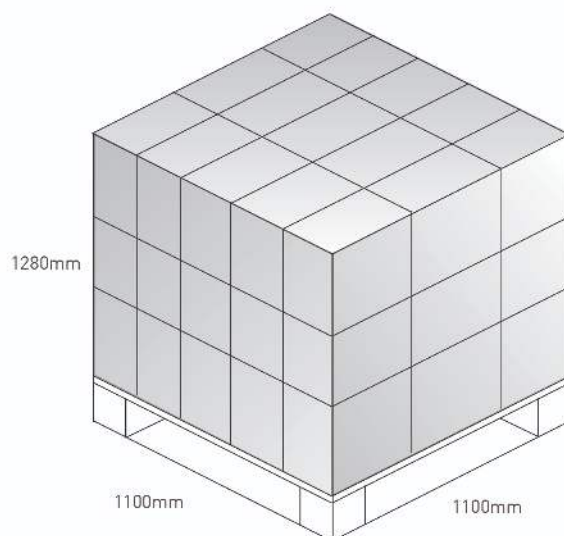

Taoglas makes no warranties based on the accuracy or completeness of the contents of this document and reserves the right to make changes to specifications and product descriptions at any time without notice. Taoglas reserves all rights to this document and the information contained herein.

Reproduction, use or disclosure to third parties without express permission is strictly prohibited.

Copyright © Taoglas Ltd.