

Dear customer

LAPIS Semiconductor Co., Ltd. ("LAPIS Semiconductor"), on the 1st day of October, 2020, implemented the incorporation-type company split (shinsetsu-bunkatsu) in which LAPIS established a new company, LAPIS Technology Co., Ltd. ("LAPIS Technology") and LAPIS Technology succeeded LAPIS Semiconductor's LSI business.

Therefore, all references to "LAPIS Semiconductor Co., Ltd.", "LAPIS Semiconductor" and/or "LAPIS" in this document shall be replaced with "LAPIS Technology Co., Ltd."

Furthermore, there are no changes to the documents relating to our products other than the company name, the company trademark, logo, etc.

Thank you for your understanding.

LAPIS Technology Co., Ltd.
October 1, 2020

ML630Q464/466 Reference Board User's Manual

Issue Date: Feb.23.2017.



NOTES

- 1) The information contained herein is subject to change without notice.
- 2) Although LAPIS Semiconductor is continuously working to improve product reliability and quality, semiconductors can break down and malfunction due to various factors. Therefore, in order to prevent personal injury or fire arising from failure, please take safety measures such as complying with the derating characteristics, implementing redundant and fire prevention designs, and utilizing backups and fail-safe procedures. LAPIS Semiconductor shall have no responsibility for any damages arising out of the use of our Products beyond the rating specified by LAPIS Semiconductor.
- 3) Examples of application circuits, circuit constants and any other information contained herein are provided only to illustrate the standard usage and operations of the Products. The peripheral conditions must be taken into account when designing circuits for mass production.
- 4) The technical information specified herein is intended only to show the typical functions of the Products and examples of application circuits for the Products. No license, expressly or implied, is granted hereby under any intellectual property rights or other rights of LAPIS Semiconductor or any third party with respect to the information contained in this document; therefore LAPIS Semiconductor shall have no responsibility whatsoever for any dispute, concerning such rights owned by third parties, arising out of the use of such technical information.
- 5) The Products are intended for use in general electronic equipment (i.e. AV/OA devices, communication, consumer systems, gaming/entertainment sets) as well as the applications indicated in this document.
- 6) The Products specified in this document are not designed to be radiation tolerant.
- 7) For use of our Products in applications requiring a high degree of reliability (as exemplified below), please contact and consult with a LAPIS Semiconductor representative: transportation equipment (i.e. cars, ships, trains), primary communication equipment, traffic lights, fire/crime prevention, safety equipment, medical systems, servers, solar cells, and power transmission systems.
- 8) Do not use our Products in applications requiring extremely high reliability, such as aerospace equipment, nuclear power control systems, and submarine repeaters.
- 9) LAPIS Semiconductor shall have no responsibility for any damages or injury arising from non-compliance with the recommended usage conditions and specifications contained herein.
- 10) LAPIS Semiconductor has used reasonable care to ensure the accuracy of the information contained in this document. However, LAPIS Semiconductor does not warrant that such information is error-free and LAPIS Semiconductor shall have no responsibility for any damages arising from any inaccuracy or misprint of such information.
- 11) Please use the Products in accordance with any applicable environmental laws and regulations, such as the RoHS Directive. For more details, including RoHS compatibility, please contact a ROHM sales office. LAPIS Semiconductor shall have no responsibility for any damages or losses resulting non-compliance with any applicable laws or regulations.
- 12) When providing our Products and technologies contained in this document to other countries, you must abide by the procedures and provisions stipulated in all applicable export laws and regulations, including without limitation the US Export Administration Regulations and the Foreign Exchange and Foreign Trade Act.
- 13) This document, in part or in whole, may not be reprinted or reproduced without prior consent of LAPIS Semiconductor.
- 14) ARM, Cortex and Thumb are trademarks of ARM Limited

Copyright 2016 LAPIS Semiconductor Co., Ltd.

LAPIS Semiconductor Co.,Ltd.

2-4-8 Shinyokohama, Kouhoku-ku,
Yokohama 222-8575, Japan
<http://www.lapis-semi.com/en/>

Preface

This manual describes the operation of the ReferenceBoard of the 32-bit microcontroller ML630Q464/466.

The following manuals are also available. Read them as necessary.

- ML630Q464/466 User's Manual
 - Description of the ML630Q464/466

Table of Contents

1. GENERAL DESCRIPTION	1-1
1.1. OVERVIEW	1-1
1.2. MAIN COMPONENTS	1-2
2. FUNCTIONS.....	2-1
2.1. LEDs	2-1
2.2. RESET SWITCH	2-1
2.3. GENERAL-USE SWITCH	2-1
2.4. VREF JUMPER	2-2
2.5. VDD_SEL, USB_SEL JUMPER.....	2-2
2.6. RC-ADC	2-3
2.7. SA-ADC	2-3
2.8. LCD BIAS SELECTION	2-4
2.9. UART TO USB.....	2-4
3. CONNECTORS	3-1
3.1. DEBUG.....	3-1
3.2. CN1	3-1
3.3. CN2.....	3-2
3.4. CN3.....	3-2
3.5. CN4.....	3-3
4. SCHEMATICS.....	4-1

Chapter 1

General Description

This chapter gives a general description of the ML630Q464/466 Reference Board.

1. General Description

1.1. Overview

ML630Q464/466 Reference board is prepared by LAPIS SEMICONDUCTOR to have you study the operations of ML630Q464/466.

The board is arranged so that necessary components are mounted by you according to your purpose, then only minimum necessary components are mounted on the board by LAPIS SEMICONDUCTOR for brief use of ML630Q464/466.

By using the board with ARM Debugger, not only Software development/debugging but also writing to Flash ROM in the devices are possible.

This board also works in stand alone mode with external power supply without ARM Debugger.

1.2. Main Components

Figure 1-1 shows the ML630Q464/466 Reference Board and Table 1-1 lists the main components of the board.

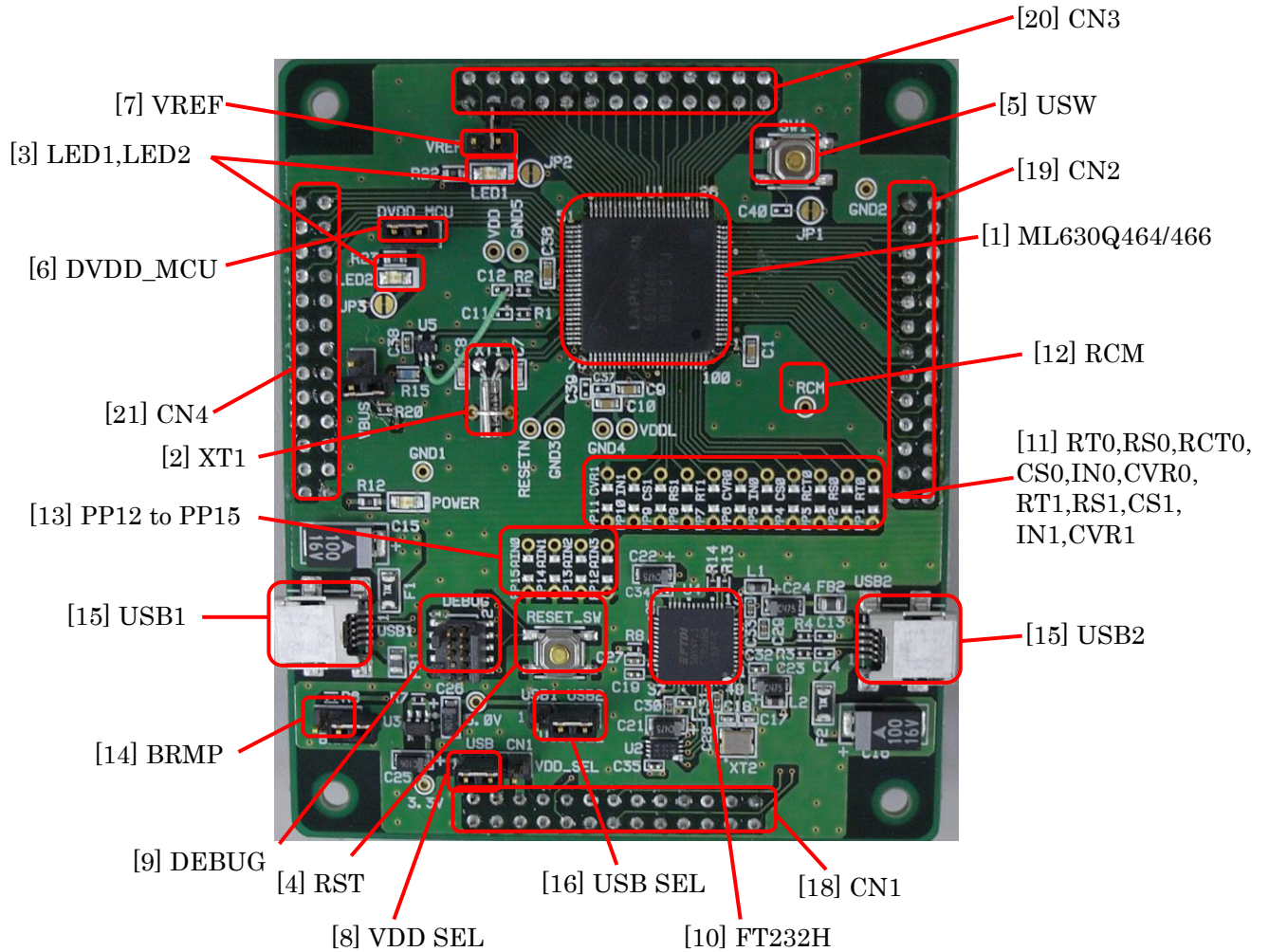

Table 1-1 Components Mounted on the reference board

Number	Name	Description
1	ML630Q464/466	Microcontroller
2	XT1	32.768kHz oscillator
3	LED1,LED2	Light emitting diodes LED1: Connected to P31 through JP2. LED2: Connected to P56 through JP3.
4	RST	Reset switch.
5	USW	General -use switch. Connected to P30 through JP1.
6	DVDD_MCU	Jumper for measuring the LSI current.
7	VREF	Jumper for selecting the input voltage.
8	VDD SEL	The power supply of the microcontroller is selected by this jumper. 1-2: The power supply is supplied from USB. 2-3: The power supply is supplied from CN1.
9	DEBUG	Connector for Debugger.
10	FT232H	Convert from USB to UART.
11	RT0, RS0, RCT0, CS0, IN0, CVR0, RT1, RS1, CS1, IN1, CVR1	Resistors and capacitors for RC-ADC.
12	RCM	Monitor pin of RC-ADC.
13	PP12 to PP15	Used for the capacitors of AIN0 to AIN3 pins.
14	BRMP	Jumper of the boot select.
15	USB1, USB2	USB connector USB1: Connected to DP,DM of ML630Q464/466 USB2: Connected to P36,P37 of ML630Q464/466 through FT232H via zero-ohm resistors.
16	USB_SEL	The power supply of the microcontroller is selected by this jumper. 1-2: The power supply is supplied from USB1. 2-3: The power supply is supplied from USB2
17	CN1	Connector for peripherals.
18	CN2	Connector for peripherals.
19	CN3	Connector for peripherals.
20	CN4	Connector for peripherals.

Chapter 2

Functions

This chapter gives the functions fo ML630Q464/466 reference board.

2. Functions

2.1. LEDs

P31, P56 can drive direct to LED. When separate P31 or P56 from LEDs, please cut the wiring of JP2 or JP3.

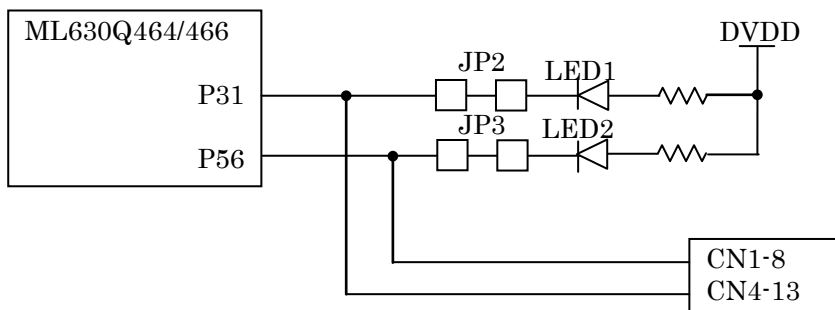

2.2. Reset switch

RESET_N pin is connected to the push switch(RESET_SW) and CN1 connector. The RESET_N pin has the internal pull-up resistor.

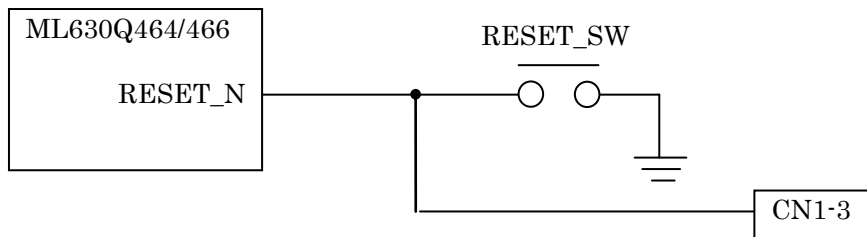

2.3. General-use switch

P30 pin is connected to the general-use switch(SW1). When SW1 is used, connect the pull-up resistor by setting the P3CON register of ML630Q464/466. When separate P30 from USW, cut the wiring of JP1.

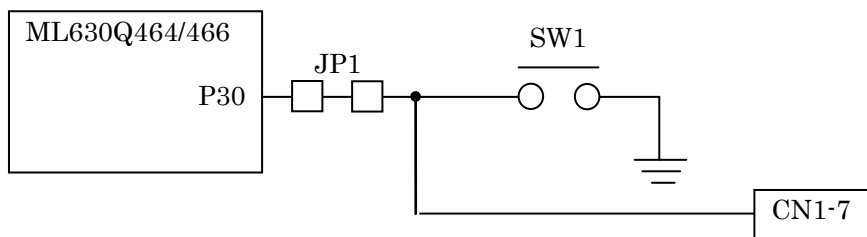

2.4. VREF jumper

VREF is connected to VDD with VREF jumper.

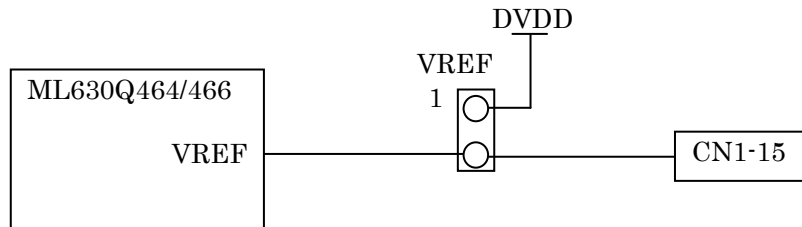

2.5. VDD_SEL, USB_SEL jumper

The power supply of the ML630Q464/466 can select from USB1, USB2 and CN1 connector.

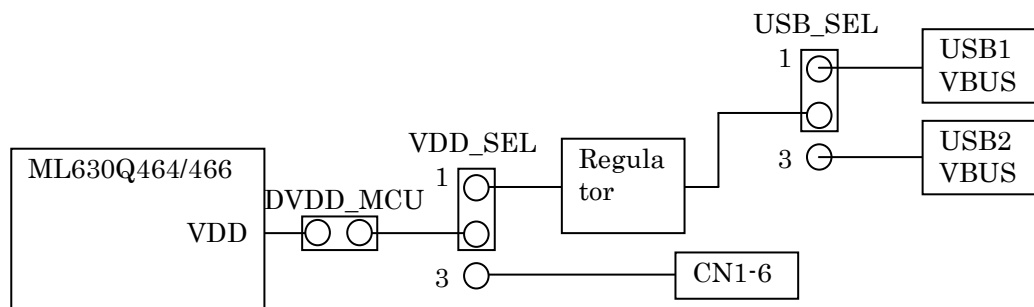

power supply	jumper setting
USB1 VBUS	USB_SEL: 1-2 short VDD_SEL: 1-2 short DVDD_MCU: short
USB2 VBUS	USB_SEL: 2-3 short VDD_SEL: 1-2 short DVDD_MCU: short
CN1-6	USB_SEL: - VDD_SEL: 2-3 short DVDD_MCU: short

*: DVDD_MCU is used, when the consumption current of the ML630Q464/466 is measured.
Usually make it short.

2.6. RC-ADC

When use the channel-0 of RC-ADC, please mount capacitors and resistors at RT0, RS0, RCT0, CS0, IN0 and CVR0. When use the channel-1 of RC-ADC, please mount capacitors and resistors at RT1, RS1, CS1 and CVR1. RC oscillation can be monitored at RCM.

Example RS0-CS0 oscillation mode

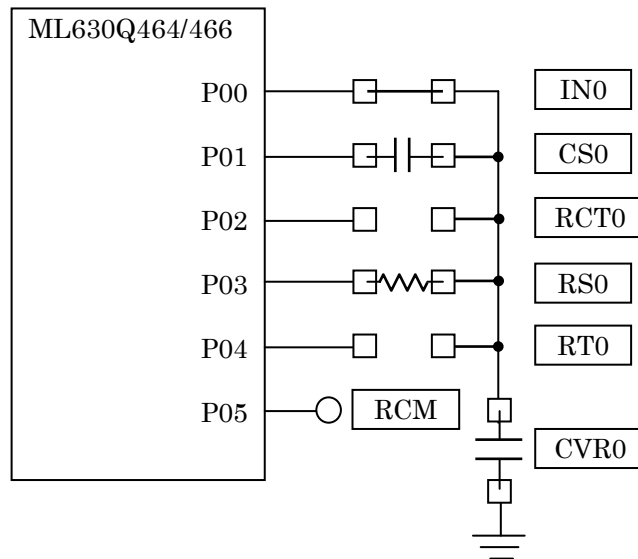

2.7. SA-ADC

When use the SA-ADC, please connect the input to be measured at the P32-35(AIN0-3), P20-23(AIN4-7) or P00-03(AIN8-11). When use the noise reduction capacitor for AIN0-11, please mount at PP12 to PP15, PP7 to PP10 or PP2 to PP5. And please note that the 0 ohm resistor must be mounted on PP11, when the noise reduction capacitors are necessary at PP7-10, and also the 0 ohm resistor must be mounted on PP6, when the noise reduction capacitors are necessary at PP2-5.

Example AIN9 needs the noise reduction capacitor.

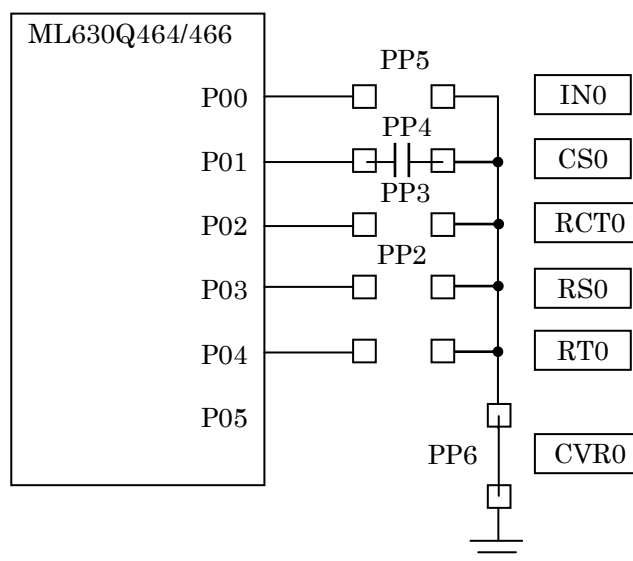

2.8. LCD bias selection

By the bias setting of the LCD, please mount the 0 ohm registers on R21.

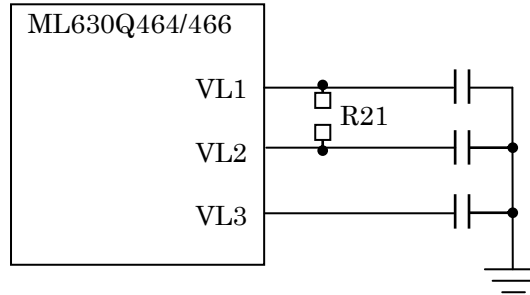

bias setting	jumper setting
1/2 bias	0 ohm registers mount on R21.
1/3 bias	0 ohm resistor does not mount .

2.9. UART to USB

The UART is connected to USB2 connector through FT232H. Only P36,P37 are connected to USB2 connector.

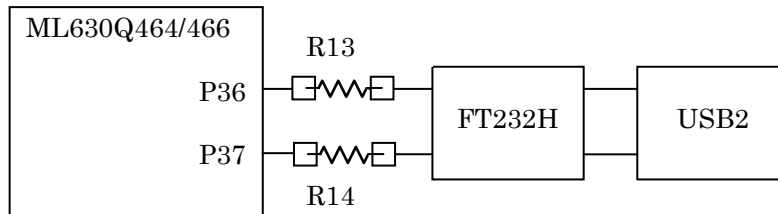

Chapter 3

Connectors

This chapter describes the connectors mounted on the ML630Q464/466 Reference Board.

3. Connectors

3.1. DEBUG

PIN No	Signal name	I/O	Destination	PIN No	Signal name	I/O	Destination
1	VTref	O	VDD	2	SWDIO	I/O	SWD
3	GND	-	VSS	4	SWCLK	I	SWC
5	GND	-	VSS	6	SWO	O	N.C.
7	KEY	-	N.C.	8	TDI	-	N.C.
9	GND	-	VSS	10	nSRST	I	RESET_N

3.2. CN1

PIN No	Signal name	I/O	Destination	PIN No	Signal name	I/O	Destination
1	-	-	-	2	-	-	-
3	RESET_N	I	RESET_N	4	GND	-	VSS
5	-	-	-	6	DVDD	-	VDD
7	P30	I/O	P30_CMP0P	8	P31	I/O	P31_CMP0M
9	P32	I/O	P32_CMP1P	10	P33	I/O	P33_CMP1M
11	P34	I/O	P34_AIN0	12	P35	I/O	P35_AIN1
13	P36	I/O	P36_TMCKI4	14	P37	I/O	P37_TMCKI5
15	VREF	I	VREF	16	P20	I/O	P20_AIN4
17	P21	I/O	P21_AIN5	18	P22	I/O	P22_AIN6
19	P23	I/O	P23_AIN7	20	P00	I/O	P00_AIN8
21	P01	I/O	P01_AIN9	22	P02	I/O	P02_AIN10
23	P03	I/O	P03_AIN11	24	P04	I/O	P04
25	P05	I/O	P05	26	GND	-	VSS

3.3. CN2

PIN No	Signal name	I/O	Destination	PIN No	Signal name	I/O	Destination
1	-	-	-	2	-	-	-
3	-	-	-	4	-	-	-
5	-	-	-	6	P63	I/O	P63_COM7
7	P62	I/O	P62_COM6	8	P61	I/O	P61_COM5
9	P60	I/O	P60_COM4	10	COM3	O	COM3
11	COM2	O	COM2	12	COM1	O	COM1
13	COM0	O	COM0	14	GND	-	VSS
15	SEG0	O	SEG0	16	SEG1	O	SEG1
17	SEG2	O	SEG2	18	SEG3	O	SEG3
19	SEG4	O	SEG4	20	SEG5	O	SEG5
21	SEG6	O	SEG6	22	SEG7	O	SEG7
23	SEG8	O	SEG8	24	SEG9	O	SEG9
25	SEG10	O	SEG10	26	GND	-	VSS

3.4. CN3

PIN No	Signal name	I/O	Destination	PIN No	Signal name	I/O	Destination
1	SEG11	O	SEG11	2	SEG12	O	SEG12
3	SEG13	O	SEG13	4	SEG14	O	SEG14
5	SEG15	O	SEG15	6	SEG16	O	SEG16
7	SEG17	O	SEG17	8	SEG18	O	SEG18
9	SEG19	O	SEG19	10	SEG20	O	SEG20
11	SEG21	O	SEG21	12	SEG22	O	SEG22
13	SEG23	O	SEG23	14	SEG24	O	SEG24
15	SEG25	O	SEG25	16	SEG26	O	SEG26
17	SEG27	O	SEG27	18	SEG28	O	SEG28
19	SEG29	O	SEG29	20	SEG30	O	SEG30
21	SEG31	O	SEG31	22	SEG32	O	SEG32
23	SEG33	O	SEG33	24	P40	I/O	P40_SEG34
25	P41	I/O	P41_SEG35	26	GND	-	VSS

3.5. CN4

PIN No	Signal name	I/O	Destination	PIN No	Signal name	I/O	Destination
1	P42	I/O	P42_SEG36	2	P43	I/O	P43_SEG37
3	P44	I/O	P44_SEG38	4	P45	I/O	P45_SEG39
5	P46	I/O	P46_SEG40	6	P47	I/O	P47_SEG41
7	P50	I/O	P50_SEG42	8	P51	I/O	P51_SEG43
9	P52	I/O	P52_SEG44	10	P53	I/O	P53_SEG45
11	P54	I/O	P54_SEG46	12	P55	I/O	P55_SEG47
13	P56	I/O	P56_SEG48	14	P57	I/O	P57_SEG49
15	-	-	-	16	-	-	-
17	-	-	-	18	-	-	-
19	-	-	-	20	-	-	-
21	-	-	-	22	-	-	-
23	-	-	-	24	-	-	-
25	-	-	-	26	GND	-	VSS

Chapter 4

Schematics

This chapter describes the schematics of ML630Q464/466 Reference Board.

4. Schematics

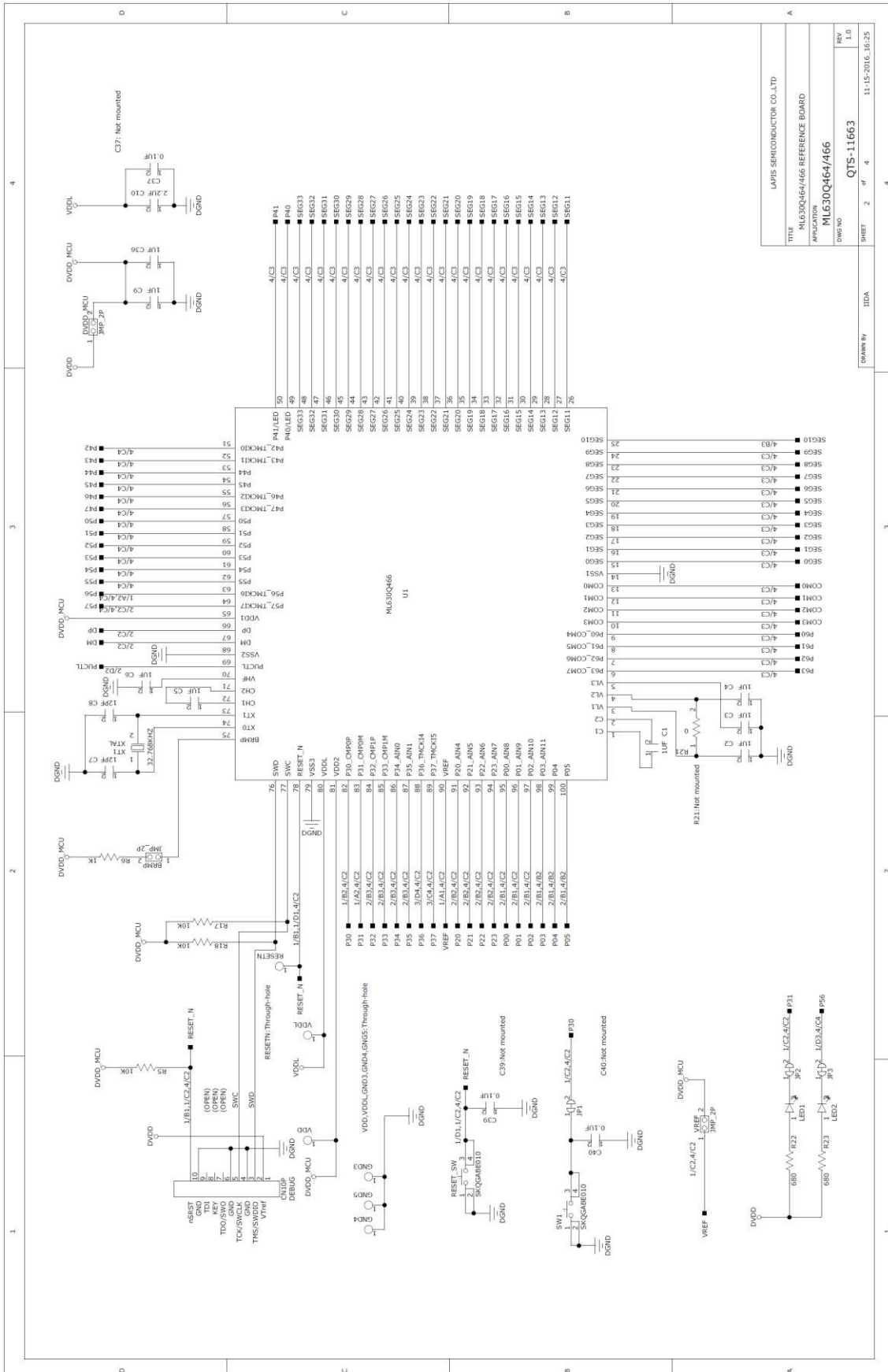

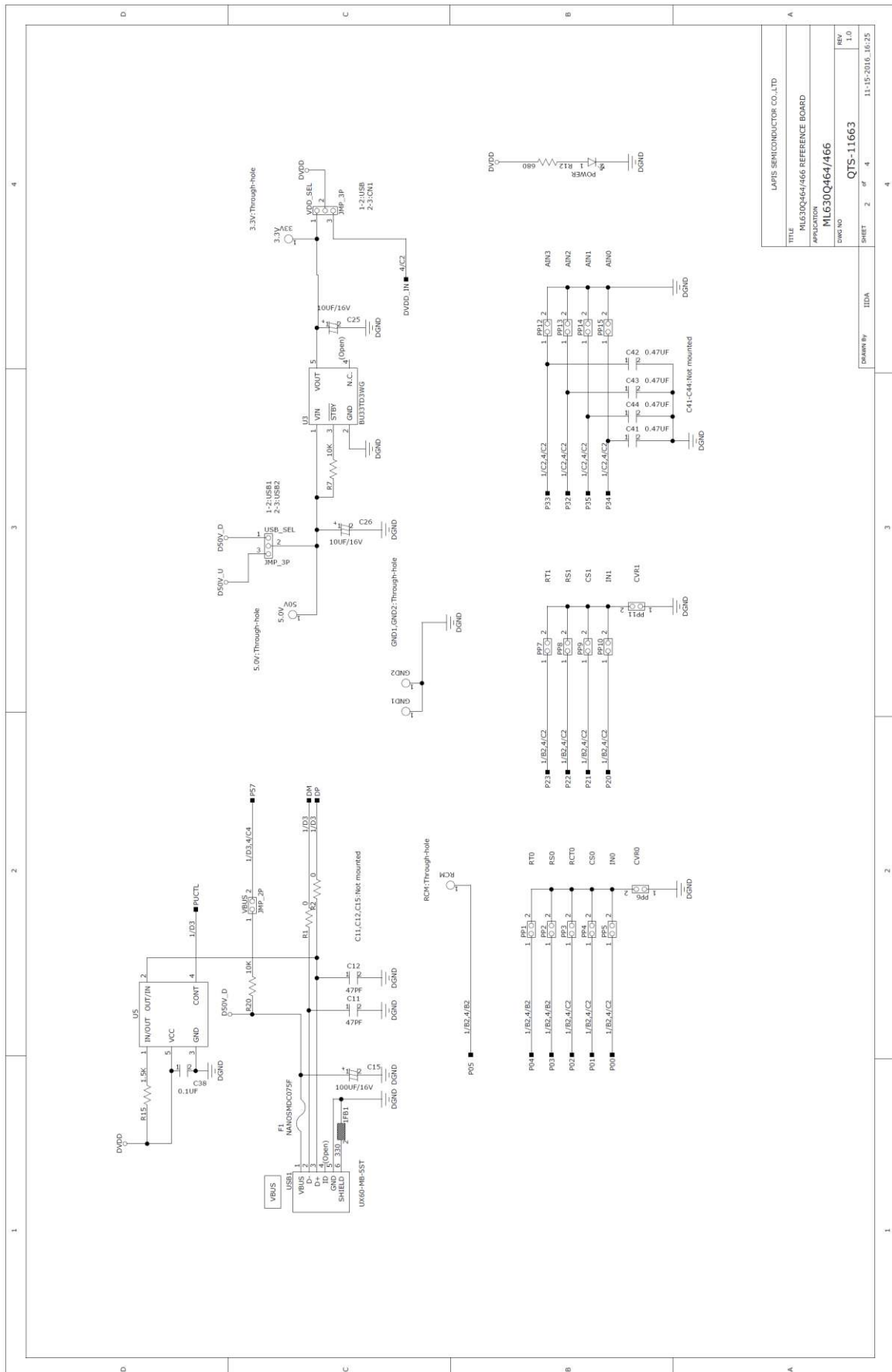

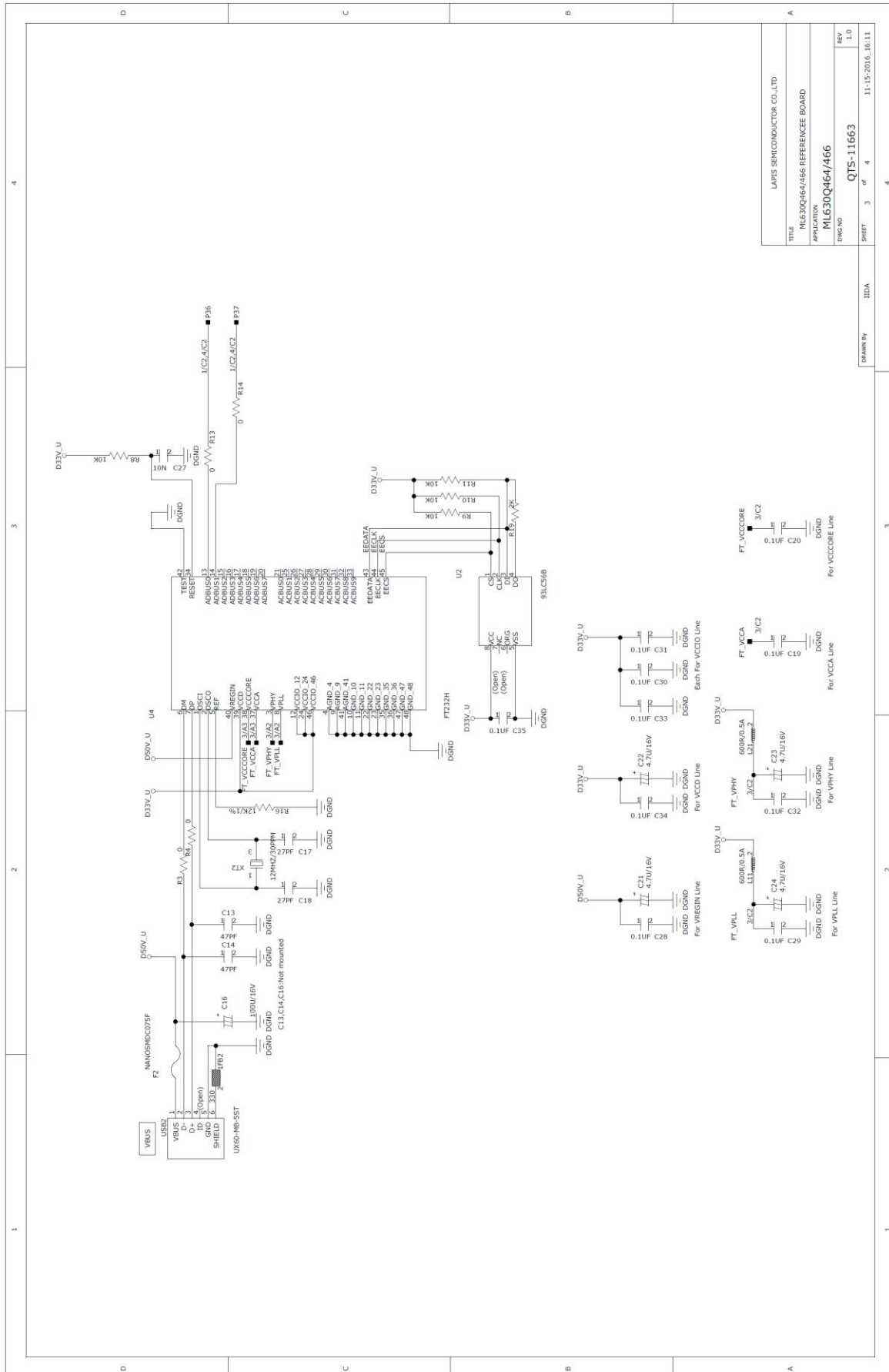

TITLE			
LAPIS SEMICONDUCTOR CO., LTD.			
APPLICATION			
ML630Q464/466 REFERENCE BOARD			
Dwg No			
QTS-11663			
SHEET		3	of 4
DRAWN BY		JIDA	
REV		1.0	
DATE		11-15-2016_16:11	

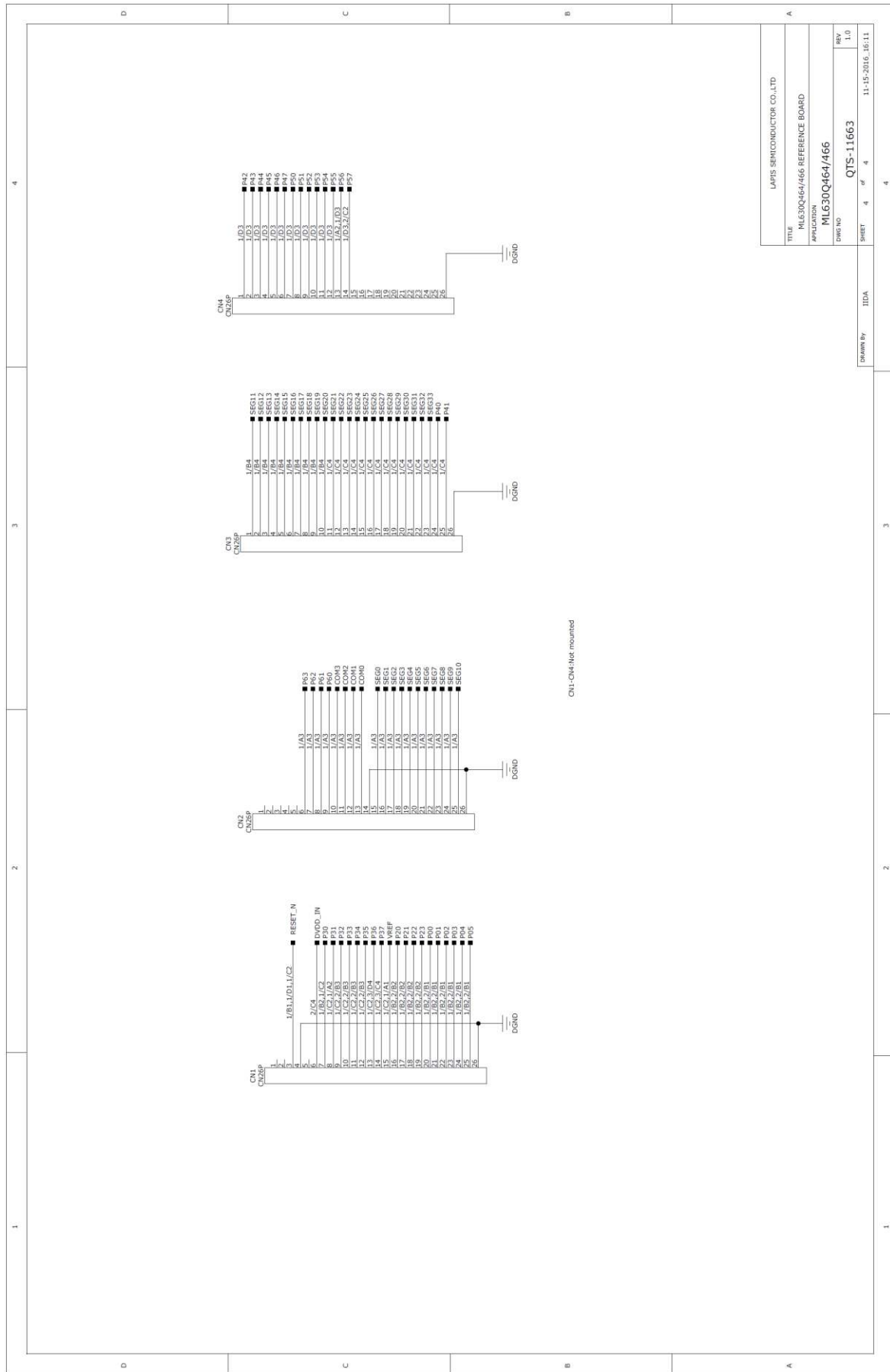

LAPIS SEMICONDUCTOR CO., LTD.	
TITLE	ML630Q464/466 REFERENCE BOARD
APPARTENANCE	ML630Q464/466
DESIGN NO	Q7S-11663
REV	1.0
DATE	11-15-2016_16:11

Drawn by: IIDA

SHEET 4 of 4

CN1, CN4: Not mounted