

PART NUMBER	REV	FIRST USED
567951-1	B	854040-3

TERMINAL NAME: PIN		286548		VISIBLE CRIMP DATA (NON-AMP TERM-CUST SPEC)	
AMP	MFG P/N	286548	F6TB-14461-AA	CRIMP HEIGHT	WIRE SIZE
		A		.051 ±.002 [1.30 ±0.05mm]	18
		B		.047 ±.002 [1.19 ±0.05mm]	20
		C		NOT	USED
		D		NOT	USED
		CRIMP	SIZE	TYPE	RANGE
		WIRE	.078 [1.98mm]	F	20-18
		INSUL	.090 [2.29mm]	F	∅.086 MAX
WIRE STRIP LENGTH	TERM APPL SPEC	FEED	APPL INSTRUCTION	SET UP GAGE	LAYOUT
.197-.236	NONE	.380	SEE CUSTOMER MANUAL	NONE	L1871

QTY	REV	U/M	DWG SIZE	PART NO	DESCRIPTION	ITEM NO
2	-	C		4-354779-0	PIN, WIRE DISC (.3190)D	129
2	-	C		3-354779-3	PIN, WIRE DISC (.3155)C	128
						127
						126
1	-	A		986950-1	WASHER, FLAT PRECISION	125
1	-	A		217238-3	GENERAL INSTRUCTION PACKAGE	124
						123
						122
1	-	A		4-21028-0	PIN, SLT SPR (∅.093x.75) ST 6DE PL	121
1	-	B		690701-2	PLATE, SERIAL NO.	120
2	-	A		21899-2	WASHER, FLAT (#10) 5 G ADJ BLK	119
						118
2	-	A		21024-5	WASHER, LOCK (#10) ADJ BLOCK	117
						116
						115
2	-	A		21024-2	WASHER, LOCK (#4) FRONT STP GUIDE	114
REF	-	A		21024-4	WASHER, LOCK (#8) FEED FINGER	113
2	-	A		21024-4	WASHER, LOCK (#8) DEP-HOLD	112
REF	-	A		21024-4	WASHER, LOCK (#8) STRIPPER	111
						110
						109
1	-	A		21018-5	NUT, HEX (#6) HOLD DOWN	108
						107
						106
1	-	A		22353-8	SCR, SHLD (∅.187x.25) DRAG LEVER	105
						104
1	-	A		21009-2	SCR, SKT 5ET (1/4-20x.25 LW) RAM	103
						102
4	-	A		21017-2	SCR, DRIVE (#2x.19) ID PLATE	101
1	-	B		819347-1	PLATE, IDENTIFICATION	100
2	-	A		3-21002-0	SCR, BHC (10-32x.88) DRAG	99
1	-	A		22733-8	SCR, BHC (8-32x.38 LW) ANVIL	98
						97
1	-	A		3-21000-8	SCR, SHC (10-32x.88) MOUNTING	96
1	-	A		2-21002-7	SCR, BHC (10-32x.50) 5G ADJ BLK	95
6	-	A		2-21002-2	SCR, BHC (8-32x.50) SHEAR-TERM SUP	94
						93
						92
1	-	A		1-21002-7	SCR, SHC (6-32x.50) CAM	91
4	-	A		2-21000-7	SCR, SHC (8-32x.50) SCR BLK	90
						89
						88
						87
REF	-	A		2-22603-0	SCR, HEX HD (8-32x.31) FEED FINGER	86
2	-	A		1-21000-3	SCR, SHC (4-40x.25) F ST GUIDE	85
REF	-	A		22733-9	SCR, BHC (8-32x.50 SL) STRIPPER	84
						83
						82
1	-	A		3-22603-1	SCR, HEX (10-32x.38) 5G ADJ BL	81
						80
						79
						78
2	-	B		463310-4	BLADE, STRIPPING (#18)	77
						76
						75
1	-	A		690603-1	SPRING, ASSIST	74
1	-	A		23030-1	SCR, SKT CAP (6-32x.25) CP DSC	73
						72
						71
-1	U/M			PART NO	DESCRIPTION	ITEM NO

QTY	REV	U/M	DWG SIZE	PART NO	DESCRIPTION	ITEM NO
1	-	A		5-22280-0	SPRING, SHEAR	12
1	-	B		690461-2	STOP, SHEAR (FRONT)	11
1	-	B		462548-1	HOLDER, SHEAR (FRONT) SP	10
1	-	B		904029-1	SHEAR, FLOAT (FRONT) SP	9
1	-	C		662520-7	ANVIL	8
1	-	C		2-240641-2	SPACER, DEPRESSOR (REAR)	7
						6
						5
						4
						3
						2
						1

QTY	REV	U/M	DWG SIZE	PART NO	DESCRIPTION	ITEM NO
						70
						69
						68
						67
						66
						65
						64
						63
						62
						61
						60
						59
						58
						57
REF	-	B		694433-8	PAWL, FEED	56
						55
						54
						53
						52
1	-	A		811242-2	BUMPER, HOLDDOWN	51
1	-	A		690753-1	SPACER, TONKER	50
						49
1	-	A		690602-6	CAM, PRE-FEED 1.62 STROKE	48
						47
						46
1	-	A		690191-1	PLUG, NYLON	45
1	-	C		455673-1	RAM	44
1	-	A		690125-1	WASHER, LAMINATED	43
1	-	A		690124-1	WASHER, RAM	42
1	-	A		7-21002-9	BOLT, CRIMPER (5/16x1.00)	41
1	-	A		23241-6	BALL, STEEL	40
1	-	A		690170-1	SPRING, COMPRESSION	39
1	-	C		690142-1	DISC, INSULATION	38
1	-	D		354777-1	WIRE DISC, PLASTIC	37
1	-	A		22480-5	WASHER, SPRING	36
1	-	B		690212-1	POST, RAM	35
1	-	B		2-690786-3	SUPPORT, TERMINAL	34
1	-	C		462544-1	PLATE, BASE SPECIAL	33
1	-	A		690432-3	SCREW, ADJUSTMENT	32
1	-	B		462543-1	BLOCK, SCREW SPECIAL	31
1	-	B		455689-1	BLOCK, STRIP GUIDE ADJ	30
1	-	C		3-458144-7	PLATE, STRIP GUIDE	29
1	-	C		1-455888-5	SPACER, FRONT SHEAR DEP	28
2	-	A		1-22284-0	SPRING, DRAG	27
1	-	B		240793-1	LEVER, DRAG RELEASE	26
1	-	B		217233-1	DRAG, TERMINAL	25
1	-	D		6-690504-2	GUIDE, STRIP (REAR)	24
1	-	A		690438-4	GUIDE, STRIP (FRONT)	23
						22
1	-	A		463756-1	GUIDE, SCRAP	21
						20
1	-	C		904458-1	STRIPPER	19
						18
						17
						16
						15
						14
						13
1	-	A		5-22280-0	SPRING, SHEAR	12
1	-	B		690461-2	STOP, SHEAR (FRONT)	11
1	-	B		462548-1	HOLDER, SHEAR (FRONT) SP	10
1	-	B		904029-1	SHEAR, FLOAT (FRONT) SP	9
1	-	C		662520-7	ANVIL	8
1	-	C		2-240641-2	SPACER, DEPRESSOR (REAR)	7
						6
1	-	A		462838-1	DEPRESSOR, SHEAR (FRONT) SP	5
1	-	B		2-238011-2	SPACER, BLOCK CRIMPER	4
1	-	C		6-456134-3	CRIMPER, INSULATION	3
1	-	C		455888-9	SPACER, CRIMPER	2
1	-	C		5-458141-0	CRIMPER, WIRE	1

QTY	REV	U/M	DWG SIZE	PART NO	DESCRIPTION	ITEM NO
DIMENSIONS IN INCHES. DO NOT SCALE PRINT.						
TOLERANCES UNLESS OTHERWISE SPECIFIED:						
2 PLC DEC ±						
3 PLC DEC ±						
4 PLC DEC ±						
ANGLES ±						
SURF TEXTURE: ✓						
REMOVE BURRS, BREAK SHARP EDGES R.015 MAX						
MATERIAL: MATL - HT TR - FIN -						
DR W. HOOVER			APP T. ELBIN		AMP Incorporated Harrisburg, PA 17105-3608	
CHK OSAUG98			REL -		MACHINE REF STRIPPER CRIMPER	
NAME			SCALE		DWG NO 567951	
CERISMAN			D		SHEET 1 OF 1	
REV			APP DATE		REV B1	

THIS DRAWING IS A CONTROLLED DOCUMENT.

THIS DRAWING IS UNRELEASED. RELEASE FOR PUBLICATION BY AMP INCORPORATED. ALL RIGHTS RESERVED. COPYRIGHT 19

LOC	A
DIST	66

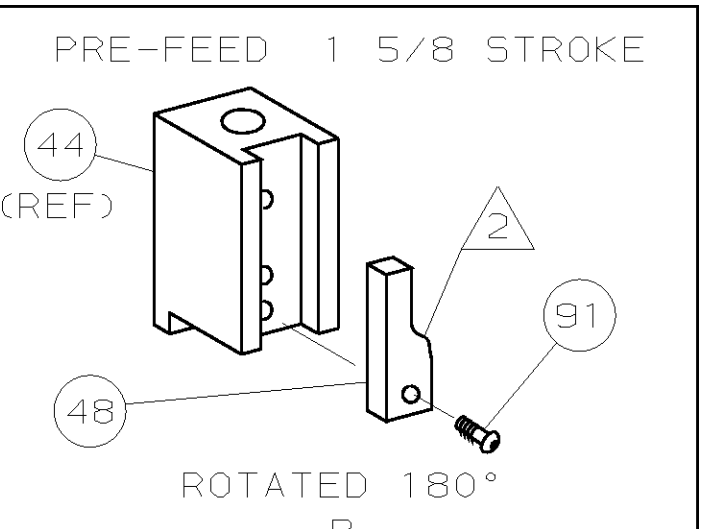

- △ 1 RECOMMENDED SPARE PARTS.
- △ 2 GREASE LIGHTLY.
- △ 3 ITEM NOT SHOWN