

THIS DRAWING IS UNPUBLISHED. RELEASED FOR PUBLICATION
 © COPYRIGHT 2010 BY TYCO ELECTRONICS CORPORATION. ALL RIGHTS RESERVED.

LOC	DIST	REVISIONS					
		P	LTR	DESCRIPTION	DATE	DWN	APVD
DW	-	B		ECR-13-001067	18JAN13	AW	WK

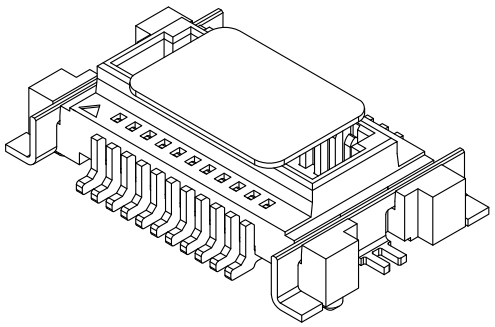

- NOTES:
- MATERIAL:
 HOUSING: LCP WITH 35% GF, UL94 V-0, NATURAL COLOR.
 CONTACTS: PHOSPHOR BRONZE.
 PEGS: BRASS.
 MYLAR: POLYSTYRENES, ORANGE COLOR.
 - FINISH:
 CONTACTS: 0.0254μm [1μ"] MIN. GOLD PLATED OVER 1.27μm [50μ"] MIN. NICKEL ON ENTIRE CONTACT.
 PEGS: 3.05μm [120μ"] MIN. MATTE-TIN OVER 1.27μm [50μ"] MIN. NICKEL.
 - REFLOW SOLDER CAPABLE TO 260°C PER TEC-109-201, CONDITION B.
 - SUBSTANCE RESTRICTIONS FOR LOW HALOGEN (BY WEIGHT):
 BROMINE (Br) ≤ 900 PPM (0.09%)
 CHLORINE (Cl) ≤ 900 PPM (0.09%)
 TOTAL CONCENTRATION OF CHLORINE (Cl) + BROMINE (Br) ≤ 1500 PPM (0.15%)
- ⚠ MATING RECEPTACLE PART NUMBER: 2041300-1.

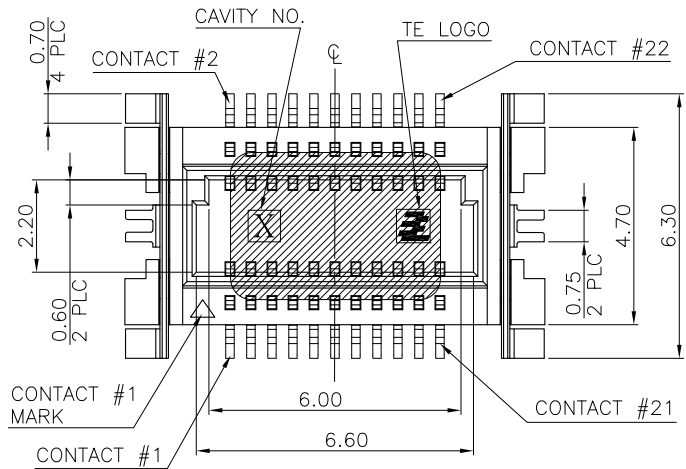
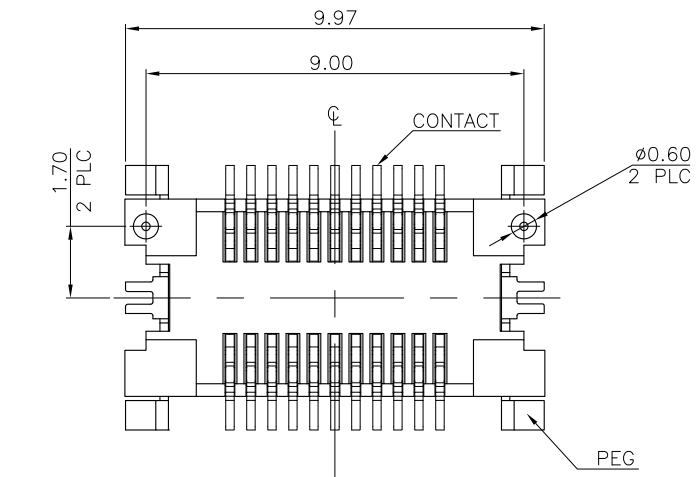
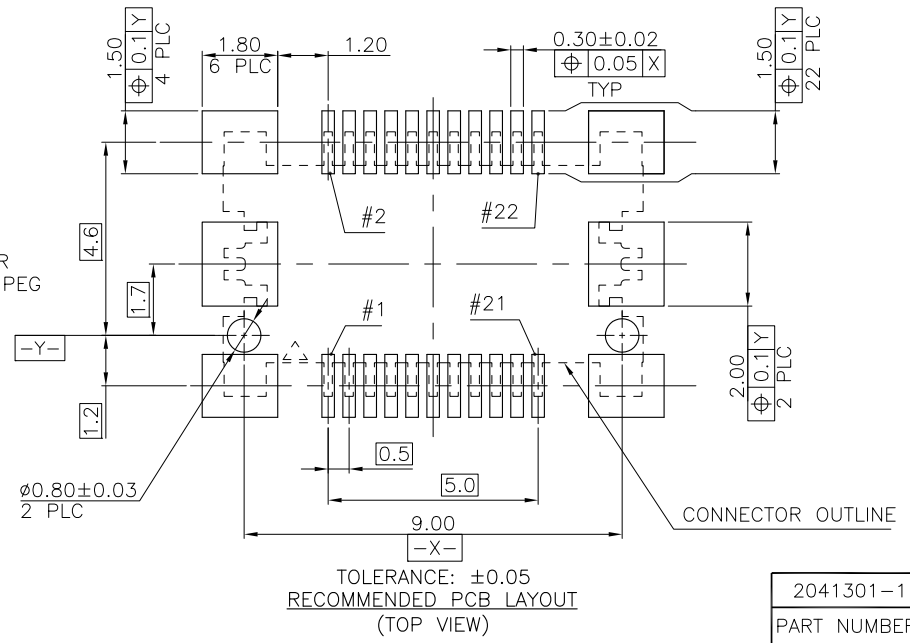
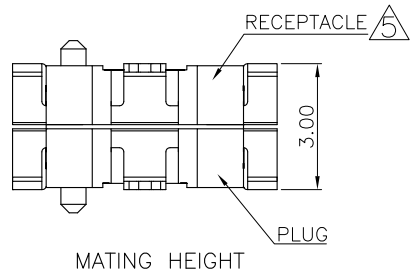
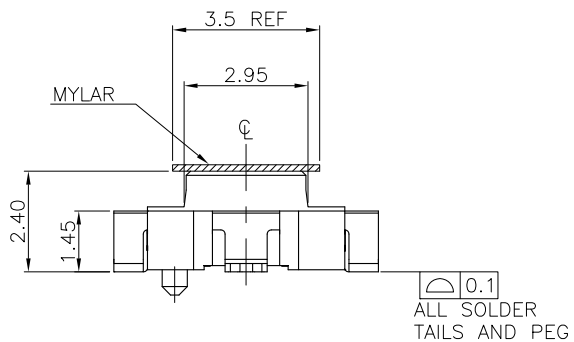
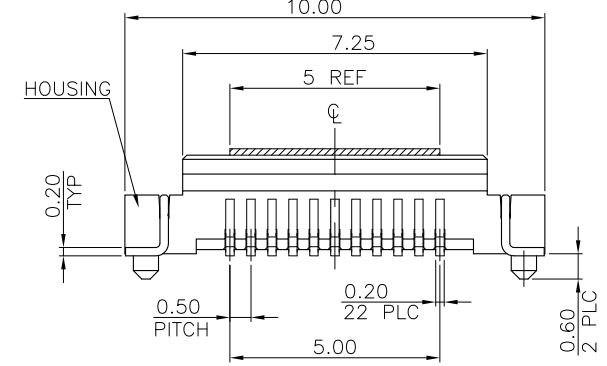

2041301-1
 PART NUMBER

THIS DRAWING IS A CONTROLLED DOCUMENT.		DWN A. WU	02NOV2010	TE Connectivity NAME 0.5 PITCH BOARD-TO-BOARD CONNECTOR, SMT, 22 POSITION, PLUG	
DIMENSIONS: MM		CHK S. CHIEN	02NOV2010		
TOLERANCES UNLESS OTHERWISE SPECIFIED:		APVD W. KODAMA	02NOV2010	PRODUCT SPEC	
0 PLC ±0.5		APPLICATION SPEC		108-57849	
1 PLC ±0.3		-		SIZE	A3
2 PLC ±0.2		-		CAGE CODE	00779
3 PLC ±0.15		-		DRAWING NO	C=2041301
4 PLC ±		-		RESTRICTED TO	-
ANGLES ± 3°		WEIGHT		0.171 GRAMS	
MATERIAL SEE NOTE		FINISH SEE NOTE		SCALE	-
		CUSTOMER DRAWING		SHEET	1 of 2
				REV	B

THIS DRAWING IS UNPUBLISHED. RELEASED FOR PUBLICATION
 © COPYRIGHT 2010 BY TYCO ELECTRONICS CORPORATION. ALL RIGHTS RESERVED.

LOC	DIST	REVISIONS					
DW	-	P	LTR	DESCRIPTION	DATE	DWN	APVD
				SEE SHEET 1.			

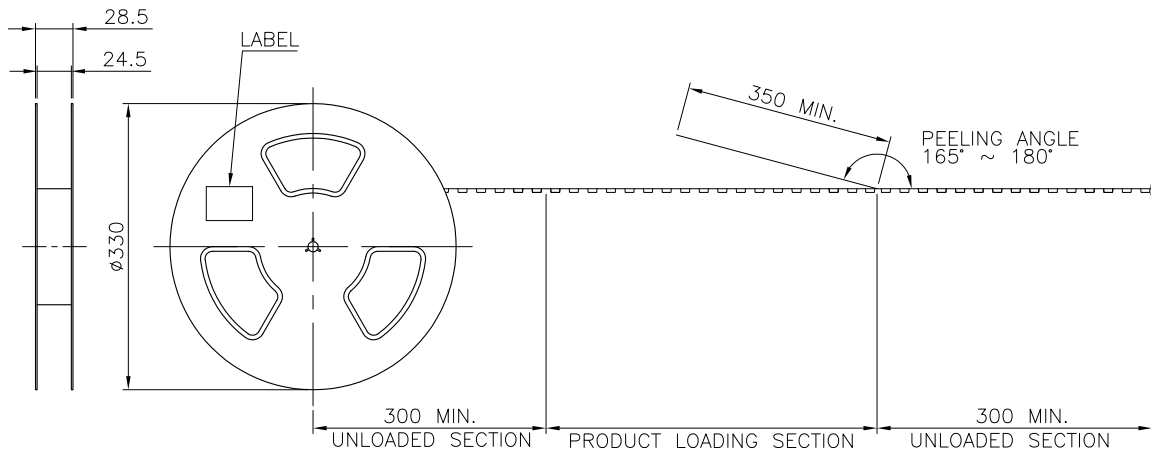

NOTES:

- MATERIAL:
 BOX: FIBREBOARD, CORRUGATED, DOUBLE WALL.
 COVER TAPE: PET, TRANSPARENT COLOR.
 CARRIER TAPE: POLYSTYRENES, TRANSPARENT COLOR.
 REEL: HIPS, BLUE COLOR.
 BAG: POLYETHYLENES, TRANSPARENT COLOR.
- EACH BAG SHALL BE INCLUDED DESICCANT.
- PEELING STRENGTH: 0.1 ~ 1.3 N (10 ~ 130 GRAMS).
- PEELING SPEED: 300 mm/min.

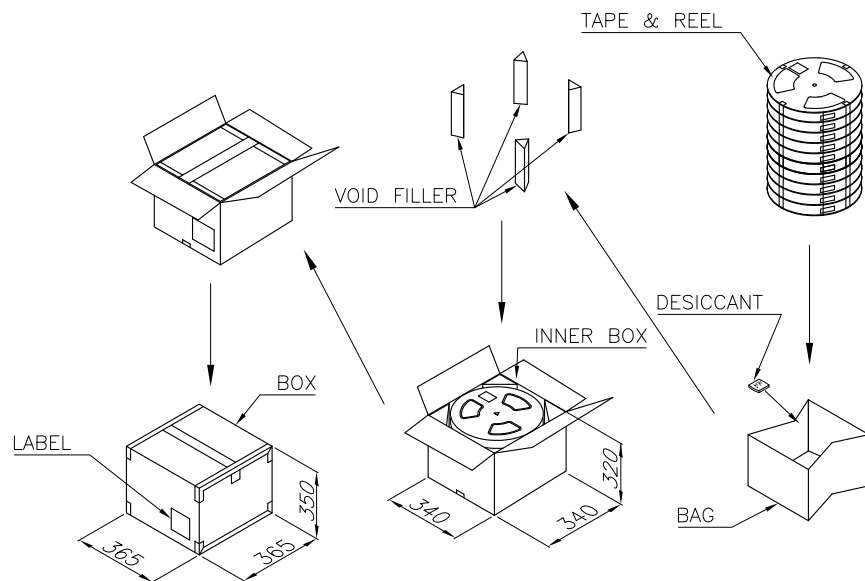
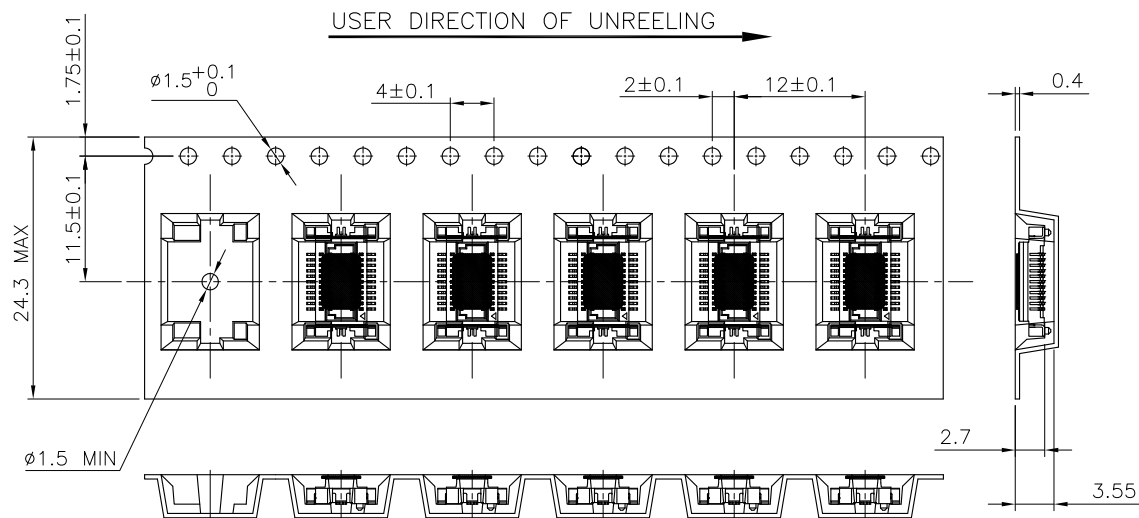

1500	10	15000 PCS	7.45 KG	2.55 KG
PCS/ TAPE	REELS/ BOX	QUANTITY	GROSS WEIGHT	NET WEIGHT

THIS DRAWING IS A CONTROLLED DOCUMENT.		DWN	A. WU	02NOV2010	 STE TE Connectivity
DIMENSIONS: MM		CHK	S. CHIEN	02NOV2010	
TOLERANCES UNLESS OTHERWISE SPECIFIED:		APVD	W. KODAMA	02NOV2010	
0 PLC ± - 1 PLC ± - 2 PLC ± - 3 PLC ± - 4 PLC ± - ANGLES ± -		PRODUCT SPEC	NAME		
MATERIAL		FINISH	-		APPLICATION SPEC
		WEIGHT	-		SIZE
		CUSTOMER DRAWING		SCALE	A3 00779 ©=2041301
				SHEET	2 of 2
				REV	B

0.5 PITCH BOARD-TO-BOARD CONNECTOR, SMT, 22 POSITION, PLUG