

HOUSING  
SEE NOTE 7

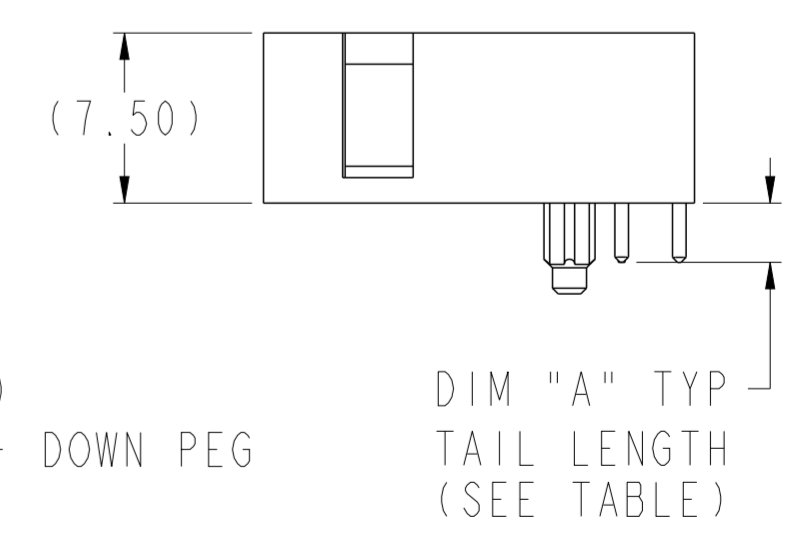
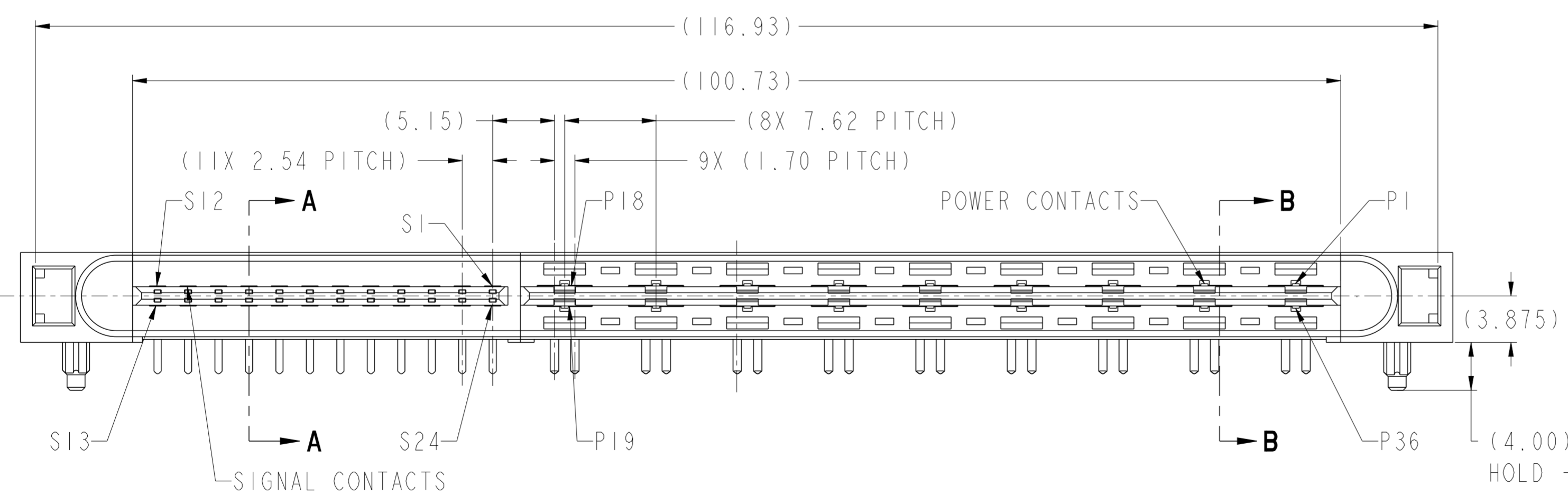
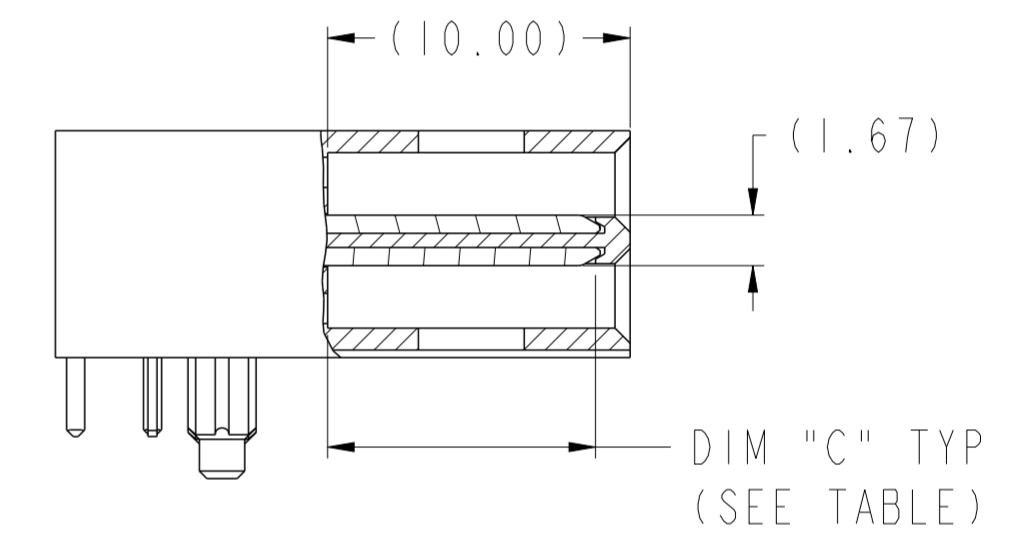
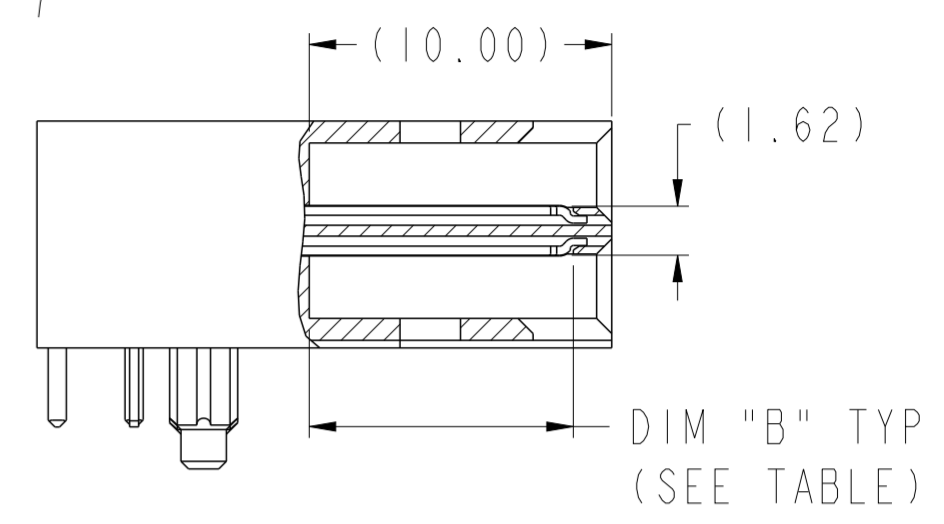

(4.00)  
HOLD - DOWN PEG

Copyright FCI.  
FCI

spec ref	-	dr	Chris Gieski	2012/03/12	projection	MM	size	A2	scale	3:1
tolerance std	ASME Y14.5	eng	Liu Jenson	2014/04/22			ecn no	ELX-DG-17541-1		
TOLERANCES UNLESS OTHERWISE SPECIFIED		chr	Jon Qin	2014/04/25			rel level	Released		
surface	ASME Y14.5	appr	Collins Lu	2014/04/25			product family	HPCE		
linear	0.X ±0.3 0.XX ±0.10 0.XXX ±0.050			title	R/A HEADER (36HP - 24S) ASM			dwg no	10119536	
angular	0° ±2°	www.fci.com		cat. no.	-			Product - Customer Drw	sheet 1 of 4	

PDS: Rev :B

STATUS:Released

Printed: Apr 25, 2014

CONTACT TYPE	TOP LAYER DESCRIPTION	TABLE 1 (HPCE / SOLDER TAILS) PLATED THROUGH-HOLE REQUIREMENTS				
		DRILLED HOLE DIAMETER	COPPER THICKNESS	TIN-LEAD THICKNESS	TIN THICKNESS	FINISHED HOLE DIAMETER
POWER & SIGNAL	TIN-LEAD	1.10-1.16 (1.15 DRILL)	0.025 - 0.050	0.005 - 0.015	--	0.94 - 1.10
	IMMERSION TIN	1.10-1.16 (1.15 DRILL)	0.025 - 0.050	--	0.9 - 1.5um	0.94 - 1.10
	COPPER (SEE NOTE 8)	1.10-1.16 (1.15 DRILL)	0.025 - 0.050	--	--	0.94 - 1.10

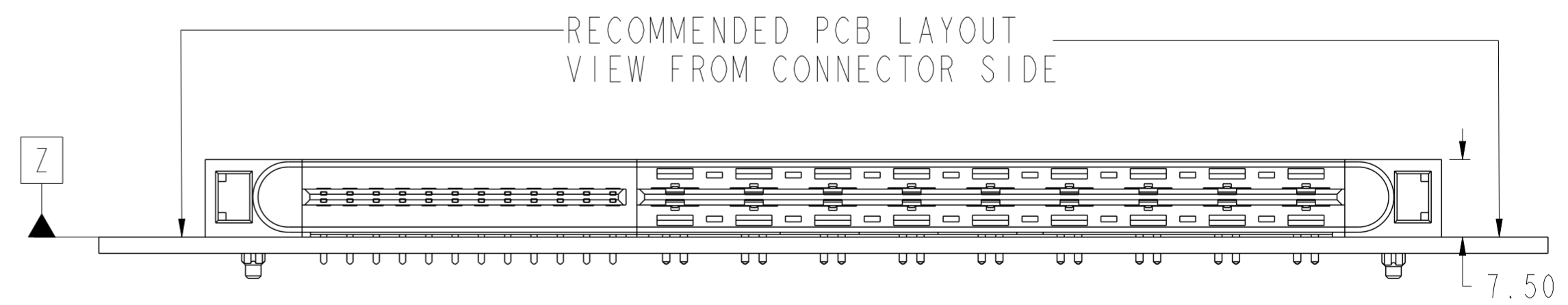
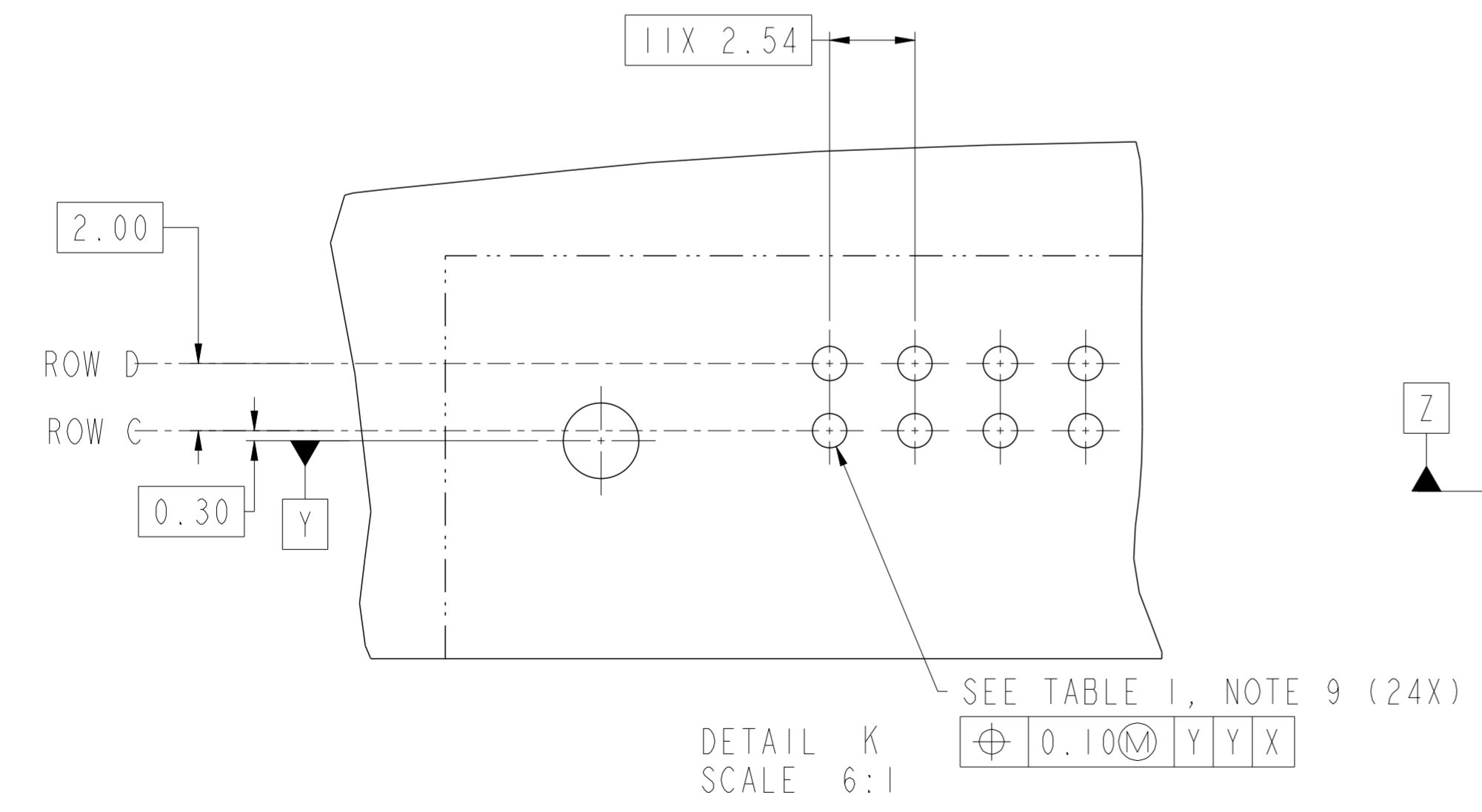
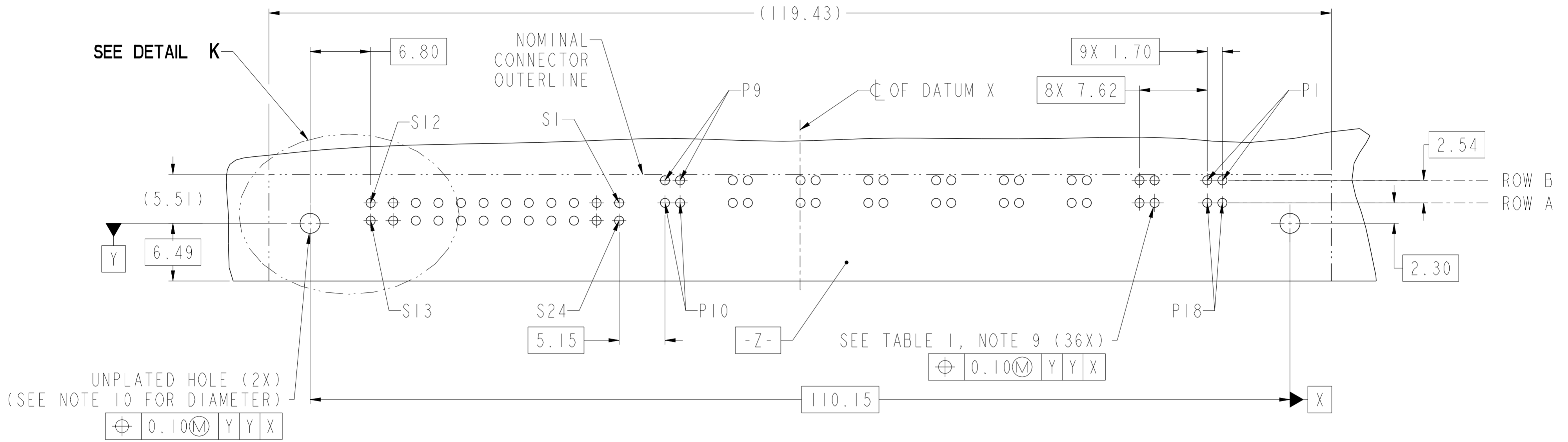

spec ref	-	dr	Chris Gieski	2012/03/12	projection	MM	size	A2	scale	3:1	
tolerance std	ASME Y14.5	eng	Liu Jenson	2014/04/22			ecn no	ELX-DG-17541-1	rel level	Released	
TOLERANCES UNLESS OTHERWISE SPECIFIED		chr	Jon Qin	2014/04/25							
		appr	Collins Lu	2014/04/25							
surface	ASME Y14.5	linear	0.X	±0.3	0.XX	±0.10	0.XXX	±0.050	angular	0°	±2°
www.fci.com		cat. no.		-		Product - Customer Drw		sheet 2 of 4		rev B	

Copyright FCI. FCI

PRODUCT PART NUMBER

10119536-□□□□□LF

BASE PART NUMBER

CONTACT AREA PLATING  
 UNDERPLATED 50u"(1.27um) MIN. NICKEL  
 1: 100u"(2.5um) MIN. Ag  
 2: 30u"(0.760um) MIN. GXT

FIRST MATE LAST BREAK PIN POSITION  
 000: ALL PINS ARE LONG PINS SEE TABLE

DIM "A", TAIL LENGTH  
 1: 2.60±0.25mm (PCB THK 1.57±0.13mm)  
 2: 3.25±0.25mm (PCB THK 2.36±0.13mm)

NOTES:

1. CONNECTOR MATERIALS:

HOUSING: HIGH TEMPERATURE THERMAL PLASTIC, BLACK UL 94V-0 COMPLIANT

CONTACTS: HIGH PERFORMANCE COPPER ALLOY.

2. CONTACT FINISH REF. GS-12-1031 SECTION 5.2

3. PRODUCT SPECIFICATION: GS-12-1031

4. APPLICATION SPECIFICATION: GS-20-0369  $\triangle B$

5. PRODUCT MARKING (FCI PART NUMBER & DATE CODE) ON HOUSING IN AREA SHOWN.

6. PACKAGING MEETS FCI SPECIFICATION GS-14-2272.  $\triangle B$

7. HOUSING COMPONENT WILL WITHSTAND EXPOSURE TO 260°C PEAK TEMPERATURE FOR 60 SECONDS IN A CONVECTION, INFRA-RED, OR VAPOR PHASE REFLOW OVEN.

8. COPPER PLATING THICKNESS IN CENTER OF VIA-HOLE CAN BE NO MORE THAN 0.003 LESS THAN OTHER AREAS.

9. ALL HOLE SIZES ARE FINISHED HOLE SIZES.

10. MOUNTING HOLES ARE UNPLATED  
 $\varnothing 2.25 \pm 0.05$  FOR SOLDER TAILS

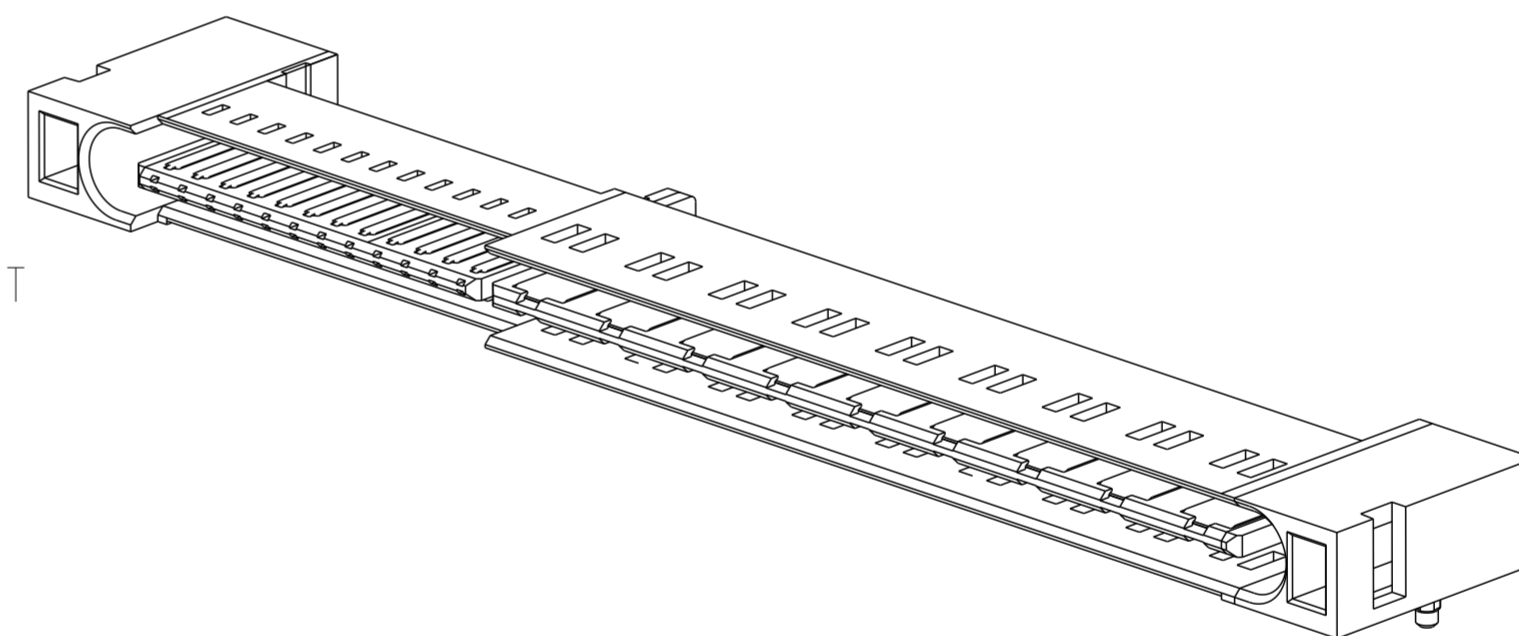

SCALE 2:1

spec ref	-	dr	Chris Gieski	2012/03/12	projection	MM	size	A2	scale	3:1											
tolerance std	ASME Y14.5	eng	Liu Jenson	2014/04/22			ecn no	ELX-DG-17541-1													
TOLERANCES UNLESS OTHERWISE SPECIFIED		chr	Jon Qin	2014/04/25			rel level	Released													
surface	<table border="1"> <tr> <td>linear</td> <td>0.X</td> <td>±0.3</td> </tr> <tr> <td></td> <td>0.XX</td> <td>±0.10</td> </tr> <tr> <td></td> <td>0.XXX</td> <td>±0.050</td> </tr> <tr> <td>angular</td> <td>0°</td> <td>±2°</td> </tr> </table>	linear	0.X	±0.3				0.XX	±0.10		0.XXX	±0.050	angular	0°	±2°	appr	Collins Lu	2014/04/25	product family	HPCE	
linear	0.X	±0.3																			
	0.XX	±0.10																			
	0.XXX	±0.050																			
angular	0°	±2°																			
ASME Y14.5		www.fci.com	cat. no.	-	Product - Customer Drw	sheet 3 of 4	title	R/A HEADER (36HP - 24S) ASM	dwg no	10119536	rev	B									

A  
B  
C  
D  
E  
F

A  
B  
C  
D  
E  
F

000	END MODULE	SIGNAL CONTACT												POWER CONTACT										END MODULE	
			12	11	10	9	8	7	6	5	4	3	2	1	9	8	7	6	5	4	3	2	1		
		ROW C	S1	S1	S1	S1	S1	S1	S1	S1	S1	S1	S1	S1	P1	P1	P1	P1	P1	P1	P1	P1	P1		P1
ROW D	S3	S3	S3	S3	S3	S3	S3	S3	S3	S3	S3	S3	P3	P3	P3	P3	P3	P3	P3	P3	P3	P3	P3	ROW B	

SIGNAL CONTACT	ROW#	S#	DIM "B"±0.25	DIM "A"±0.25	
	ROW C		S1	8.73	2.60
			S2	7.46	2.60
			S5	8.73	3.25
			S6	7.46	3.25
	ROW D		S3	8.73	2.60
			S4	7.46	2.60
			S7	8.73	3.25
		S8	7.46	3.25	

POWER CONTACT	ROW#	P#	DIM "C"±0.25	DIM "A"±0.25	
	ROW A		P1	8.86	2.60
			P2	7.59	2.60
			P5	8.86	3.25
			P6	7.59	3.25
	ROW B		P3	8.86	2.60
			P4	7.59	2.60
			P7	8.86	3.25
		P8	7.59	3.25	



Copyright FCI.

spec ref	-	dr	Chris Gieski	2012/03/12	projection	MM	size	A2	scale	3:1											
tolerance std	ASME Y14.5	eng	Liu Jenson	2014/04/22			ecn no	ELX-DG-17541-1	rel level	Released											
TOLERANCES UNLESS OTHERWISE SPECIFIED		chr	Jon Qin	2014/04/25																	
		appr	Collins Lu	2014/04/25																	
surface	<table border="1"> <tr> <td>linear</td> <td>0.X</td> <td>±0.3</td> </tr> <tr> <td></td> <td>0.XX</td> <td>±0.10</td> </tr> <tr> <td></td> <td>0.XXX</td> <td>±0.050</td> </tr> <tr> <td>angular</td> <td>0°</td> <td>±2°</td> </tr> </table>	linear	0.X	±0.3		0.XX	±0.10		0.XXX	±0.050	angular	0°	±2°			title R/A HEADER (36HP - 24S) ASME HPCE/HP2 R/A-HEADER		10119536		rev	B
linear	0.X	±0.3																			
	0.XX	±0.10																			
	0.XXX	±0.050																			
angular	0°	±2°																			
ASME Y14.5		www.fci.com		cat. no.	Product - Customer Drw		sheet 4 of 4														