

NOTES: (c)

1. RECOMMENDED SOLDER INSTRUCTION SEE SHEET 2
2. IP RATING: IP 67
3. SEALED TO WITHSTAND PRESSURE UP TO 1,45 PSI FOR 30 MINUTES AFTER SOLDERING
4. METAL SHELL: ZINC DIE CAST; min. 50µm NICKEL PLATING over COPPER
5. INSULATORS: PBT GF UL 94 V-0, BLACK
6. O-RING: SILICONE PER ASTM D2000 70 SHORE A
7. RUBBER GASKET: TPE
8. SEALING COMPOUND: EPOXY RESIN UL 94 V-0; BLACK
9. CONTACTS: COPPER ALLOY
- PLATING (SEE PART NO):
 - PLEASE ADD 1 for 30µm HARD GOLD over min. 50µm NICKEL
 - PLEASE ADD 3 for 8µm HARD GOLD over min. 50µm NICKEL
10. HEXLOCKING SCREWS: STAINLESS STEEL
11. RECOMMENDED PANEL CUT-OUT ON SHEET 2
12. RECOMMENDED TORQUE FOR MOUNTING SCREW 35Ncm (3.1 in.LB) / max.67Ncm (6 in.LB)
13. OPERATING TEMPERATURE: -40°C to +105°C
14. CONNECTOR IS PART MARKED: 15-00057□ CONEC ABC

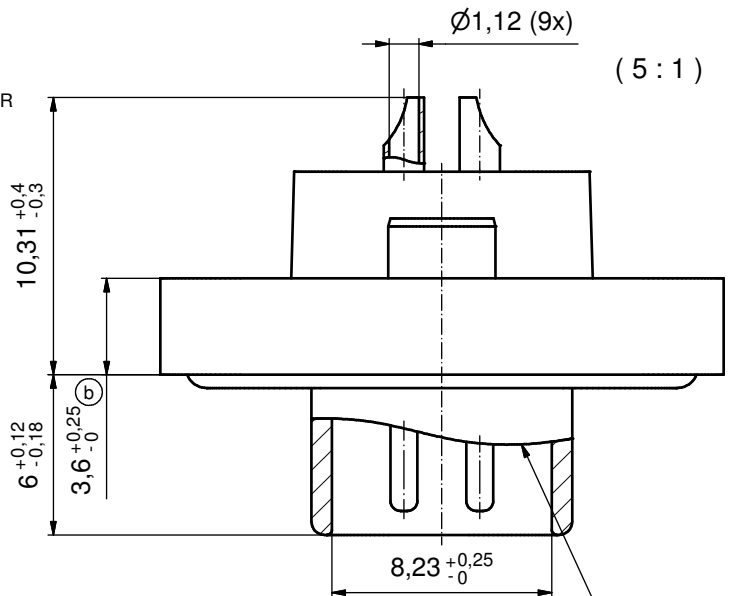

RUBBER GASKET PLACED ON TOP SURFACE OF MALE INSULATOR

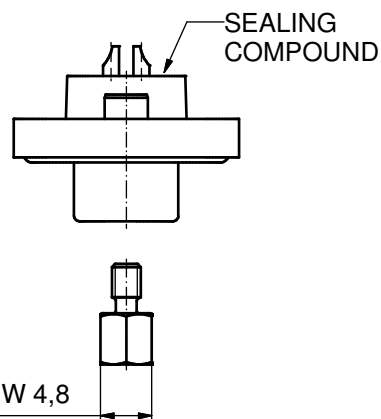
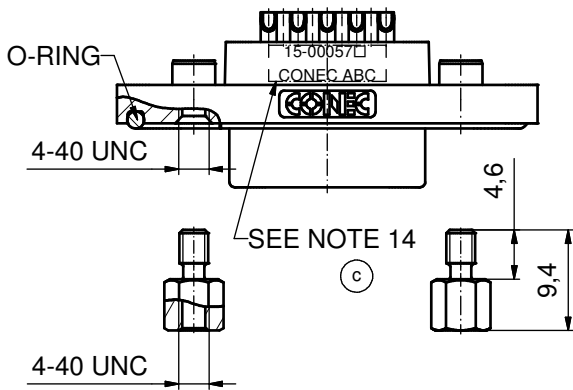
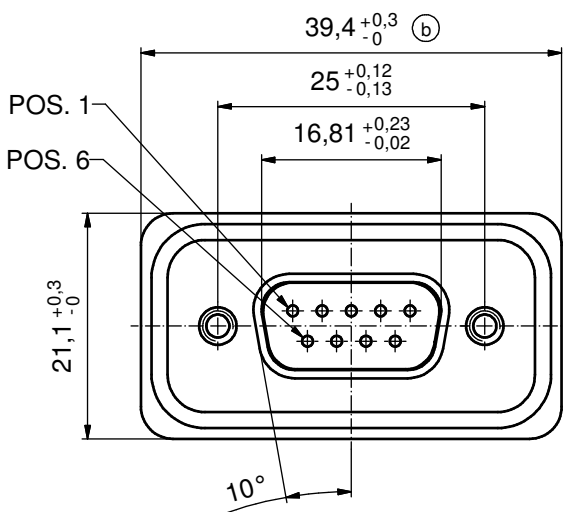
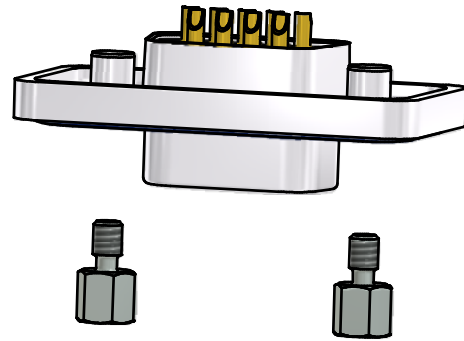

(b) AT ALL TIMES WATER RESISTANT CONNECTORS NOT IN USE SHOULD BE COVERED WITH A CONEC WATER RESISTANT CAP OR WATER TIGHT HOOD.

RoHS compliant

THIS DRAWING MAY NOT BE COPIED OR REPRODUCED IN ANY WAY, AND MAY NOT BE PASSED ON TO A THIRD PARTY WITHOUT WRITTEN PERMISSION. OWNERSHIP AND COPYRIGHT OF CONEC GmbH DO NOT ALTER CAD DRAWING BY HAND					tolerance		scale: 2:1 (5:1)
					date	name	material: see notes
					drawn	17.10.08	Petker
					appd.	22.10.08	Fischer
					norm		
2 x c	Ä5461	15.12.14	K.H.	d-old	title: D-SUB MALE 9pos. SOLDER CUP with hexlocking screw		
3 x b	Ä3435	29.09.09	HS				
a	Original				dwg no:	15K1A275	DIN-A3
rev.	description	date	name	CONEC ®		part no:	15-00057□ (see note 9)
						sh: 1/2	

Solder Instruction

1. Cable should be prepared for soldering. The cable/wires must be pretinned.
2. Insert cable/wire into solder cup.
3. Operate the soldering iron at 350 °C, 50 Watt max. and use a pencil tip.
4. Put tip to wire in solder cup.
5. After 1 second bring in solder.
6. Heat for 3 seconds longer. Do not heat contact more than 4 seconds in total.
7. Remove soldering iron.
8. Wait until solder gets rigid again.
9. Do not solder adjacent contacts consecutively, alternate position within the connector to minimize heat build up.

RECOMMENDED PANEL CUT-OUT

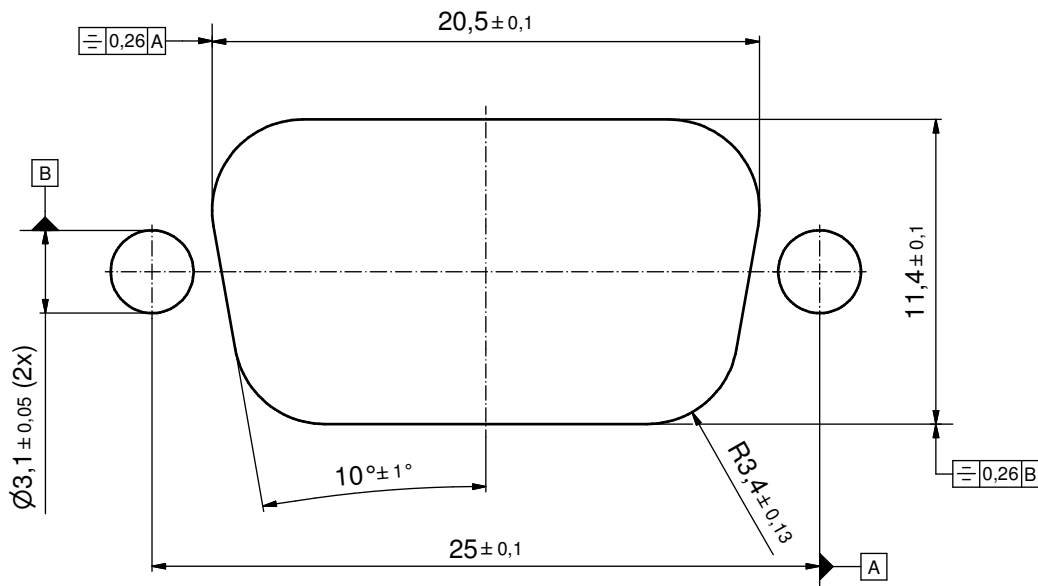

THIS DRAWING MAY NOT BE COPIED OR REPRODUCED IN ANY WAY, AND MAY NOT BE PASSED ON TO A THIRD PARTY WITHOUT WRITTEN PERMISSION. OWNERSHIP AND COPYRIGHT OF CONEC GmbH DO NOT ALTER CAD DRAWING BY HAND				tolerance		scale: 5:1
				dim. in mm		material: see sheet 1
				date	name	title: PANEL CUT-OUT D-SUB MALE 9pos. SOLDER CUP with hexlocking screw
				drawn	17.10.08 Petker	
				appd.	22.10.08 Fischer	
			norm		dwg no:	
			d-old		DIN-A3	
			rev.	description	date	name
			a	Original		
			CONEC ®			15K1A275
						part no: SEE SHEET 1
						sh: 2/2