

REVISIONS					
P	LTR	DESCRIPTION	DATE	DWN	APVD
	H	ECO-21-006957	25JUN2021	RK	MZ

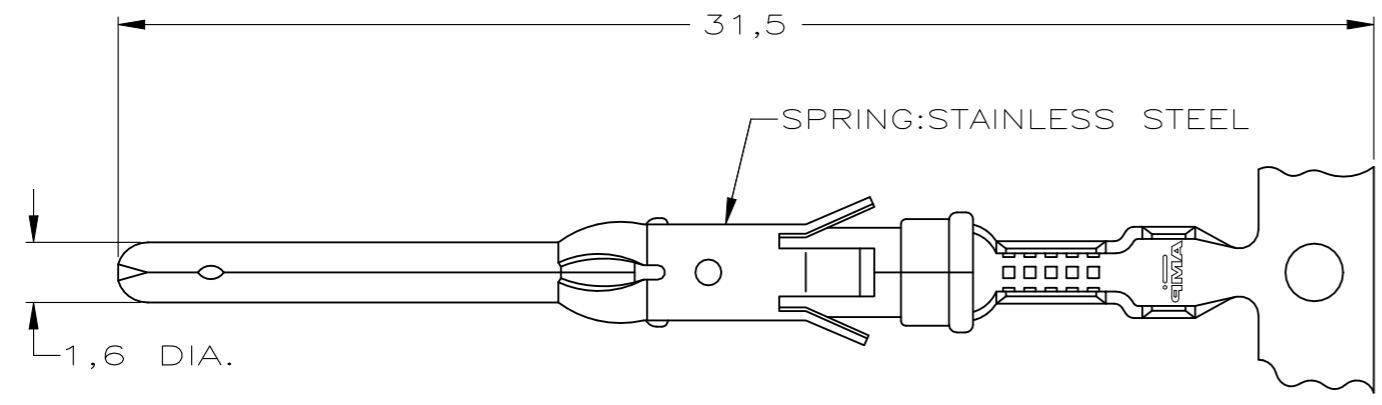

STRIP

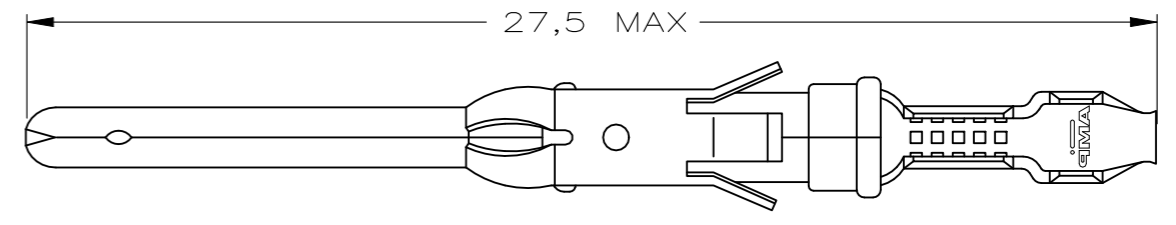

LOOSE-PIECE

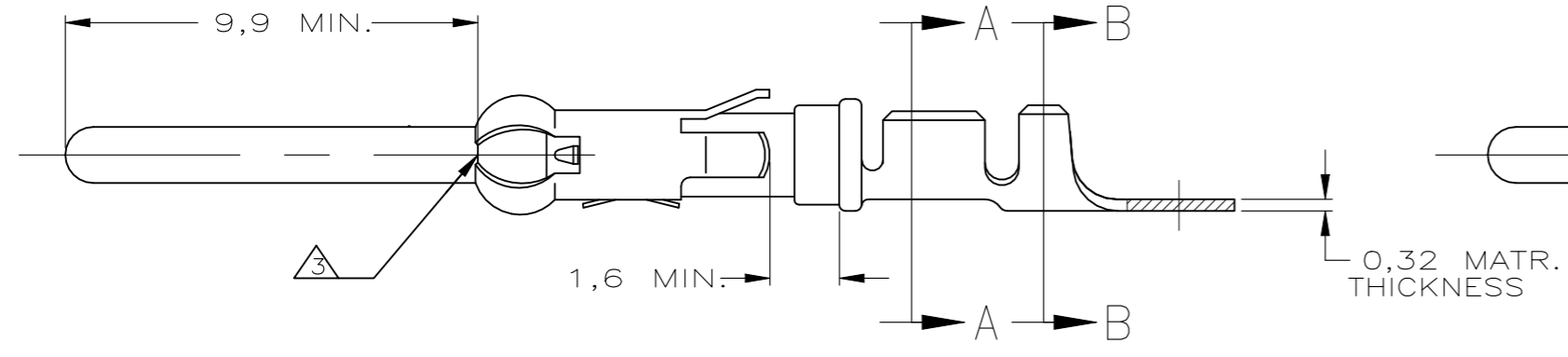

COLOR CODE: BLUE

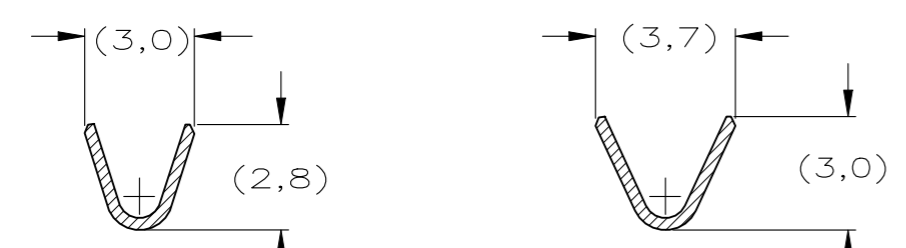

WIRE RANGE : 0,75-1,50 mm² (18-16 AWG)
 INSUL. RANGE : 2,0 -2,5 mm (.080-.100)

- NOTES :
- 1 FOR CRIMP DETAILS SEE SPEC. 114-19.000.
 - 2 MEETS PRODUCT SPECIFICATION 108-10042.
 - 3 0,40 MAX. GAP BETWEEN SPRING-NOSE AND CONTACT BODY.
 - △4 OBSOLETE PARTS: OBSOLETE CIS STREAMLINING PER D.RENAUD/D.SINISI
 - 5 OMISSION OF 6 CONTACTS MAX PER REEL OF 5000PCS.
 - △6 OBSOLETE PART

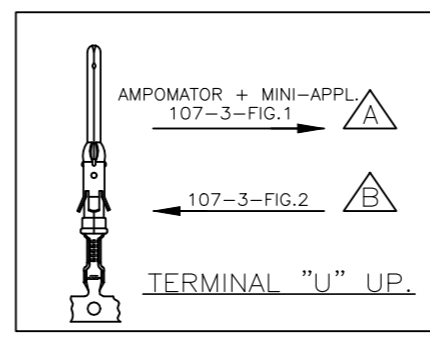

PART NUMBER	DIRECTION OF REEL	LOOSE-PIECE	MATERIAL	PLATING
△4 163766-5	△B		PH.BRONZE	EL.TIN △20
△6 163766-4	△A	△6 164839-4	PH.BRONZE	ECON.GOLD △21
△4 163766-3	△A	△6 164839-3	PH.BRONZE	SILVER △28
163766-2	△A	164839-2	PH.BRONZE	PRECIOUS METAL △22
163766-1	△A	△6 164839-1	PH.BRONZE	EL.TIN △20

NOTES	MATERIAL	THICKNESS	AREA
△20	TIN	2,0 μm	ALL OVER
△21	NICKEL GOLD TIN	0,8 μm	ALL OVER CONTACT AREA BARREL
△22	NICKEL PRECIOUS METAL TIN	1,27 μm .76 μm 1,01 μm	ALL OVER CONTACT AREA BARREL
△23	NICKEL GOLD GOLD	1,2 μm	ALL OVER CONTACT AREA ALL OVER
△27	NICKEL SILVER TIN	2,5 μm	ALL OVER CONTACT AREA BARREL
△28	SILVER	0,5 μm	ALL OVER
△29	SILVER	2,5 μm	ALL OVER

THIS DRAWING IS A CONTROLLED DOCUMENT.

DIMENSIONS:	TOLERANCES UNLESS OTHERWISE SPECIFIED:
mm	
0 PLC	± -
1 PLC	± -
2 PLC	± -
3 PLC	± -
4 PLC	± -
ANGLES	± -
MATERIAL	FINISH
-	-

DWN	L.V.D.HEYDEN	19.08.1987
CHK	P.V.D.HAGEN	-
APVD	L.V.SOEST	-
PRODUCT SPEC	108-10042	
APPLICATION SPEC	114-19000	
WEIGHT	-	



TYPE III+, SIZE 16, PIN ASS'Y,
 18-16 AWG, 2.0-2.5mm DIA INSULATION

SIZE	A3	CAGE CODE	00779	DRAWING NO	C-163766	RESTRICTED TO	-
------	----	-----------	-------	------------	----------	---------------	---