

PIM 4010 series Power Interface Module Input 36-75 V, Output up to 20 A / 780-1080 W	28701-BMR455 40 Rev C November 2017
	© Flex

Key Features

- Industry standard Quarter-brick
57.9 x 36.8 x 20.3 mm (2.28 x 1.45 x 0.80 in)
- 780 W at 39 Vin, 960 W at 48 Vin, 1080 W at 54 Vin
- High efficiency, typ. 98.8% at 780 W
- 15 A output current at 86°C, 2 m/s (300 LFM) airflow
- Low EMI design for CISPR Class B
- Monitoring via I²C
- 2000 Vdc input to management power output isolation
- Optimized for ATCA applications and PICMG 3.7 (up to 800 W input power)
- Basic insulation according to IEC 62368-1
- MTBF 2.66 Mh



General Characteristics

- Dual input power feeds and enable
- Input transient suppression (IEC & ANSI standards)
- Reverse polarity protection
- Input under voltage shutdown
- Over temperature protection
- Output current protection
- A/B Feed loss alarm
- Inrush protection and hot swap functionality
- Hold-up charge and management
- 3.3 V / up to 7 A management power output
- Highly automated manufacturing ensures quality
- ISO 9001/14001 certified supplier



Safety Approvals



Design for Environment



Meets requirements in high-temperature lead-free soldering processes.

Contents

Ordering Information	2
General Information	2
Safety Specification	3
Absolute Maximum Ratings	4
Electrical Specification	
20 A / 3.3V, 3.6-7.0 A	PIM 4610 / PIM 4710 5
Application Circuit Diagram	13
EMC Specification	14
PMBus Interface	16
Operating Information	18
Thermal Consideration	21
Connections	22
Mechanical Information	23
Soldering Information	24
Delivery Package Information	24
Product Qualification Specification	25

Technical Specification

PIM 4010 series Power Interface Module Input 36-75 V, Output up to 20 A / 780-1080 W	28701-BMR455 40 Rev C	November 2017
	© Flex	

Ordering Information

Product program	Output
PIM 4610	16 A & 3.3V, 3.6 A (7 A)
PIM 4710	20 A & 3.3V, 3.6 A (7 A)

Compatibility with RoHS requirements

The products are compatible with the relevant clauses and requirements of the RoHS directive 2011/65/EU and have a maximum concentration value of 0.1% by weight in homogeneous materials for lead, mercury, hexavalent chromium, PBB and PBDE and of 0.01% by weight in homogeneous materials for cadmium.

Exemptions in the RoHS directive utilized in Flex Power Modules products are found in the Statement of Compliance document.

Product number and Packaging

PIM 4X10 n ₁ n ₂ n ₃ n ₄				
Options	n ₁	n ₂	n ₃	n ₄
Mounting	o			
Function		o		
Lead length			o	
Delivery package				o

Flex Power Modules fulfills and will continuously fulfill all its obligations under regulation (EC) No 1907/2006 concerning the registration, evaluation, authorization and restriction of chemicals (REACH) as they enter into force and is through product materials declarations preparing for the obligations to communicate information on substances in the products.

Options	Description
n ₁	P Through hole
n ₂	D Standard config. PMBus
	DA Limited I ² C (Industry standard)
	DG PMBus and Power good pin
	DAG Limited I ² C and Power good pin
n ₃	LA 3.69 mm
	LB 4.57 mm
n ₄	/B Soft tray*

Quality Statement

The products are designed and manufactured in an industrial environment where quality systems and methods like ISO 9000, Six Sigma, and SPC are intensively in use to boost the continuous improvements strategy. Infant mortality or early failures in the products are screened out and they are subjected to an ATE-based final test. Conservative design rules, design reviews and product qualifications, plus the high competence of an engaged work force, contribute to the high quality of the products.

Example: A through-hole mounted, PMBus logic, 3.69 mm pin length product with tray packaging would be PIM 4710 PDLA.

* Standard variant (i.e. no option selected).

Warranty

Warranty period and conditions are defined in Flex Power Modules General Terms and Conditions of Sale.

General Information

Reliability

The failure rate (λ) and mean time between failures (MTBF= $1/\lambda$) is calculated at max output power and an operating ambient temperature (T_A) of +40°C. Flex Power Modules uses Telcordia SR-332 Issue 2 Method 1 to calculate the mean steady-state failure rate and standard deviation (σ).

Telcordia SR-332 Issue 2 also provides techniques to estimate the upper confidence levels of failure rates based on the mean and standard deviation.

Limitation of Liability

Flex Power Modules does not make any other warranties, expressed or implied including any warranty of merchantability or fitness for a particular purpose (including, but not limited to, use in life support applications, where malfunctions of product can cause injury to a person's health or life).

© Flex 2017

The information and specifications in this technical specification is believed to be correct at the time of publication. However, no liability is accepted for inaccuracies, printing errors or for any consequences thereof. Flex reserves the right to change the contents of this technical specification at any time without prior notice.

Mean steady-state failure rate, λ	Std. deviation, σ
377 nFailures/h	15.6 nFailures/h

MTBF (mean value) for the PIM 4x10 series = 2.66 Mh.
 MTBF at 90% confidence level = 2.53 Mh

Technical Specification

PIM 4010 series Power Interface Module Input 36-75 V, Output up to 20 A / 780-1080 W	28701-BMR455 40 Rev C November 2017
	© Flex

Safety Specification**General information**

PIM 4610 and PIM 4710 are designed in accordance with the safety standards IEC 62368-1, EN 62368-1 and UL 62368-1, *Audio/video, information and communication technology equipment - Part 1: Safety requirements*. IEC/EN/UL 62368-1 contains requirements to prevent injury or damage due to the following hazards:

- Electrical shock
- Energy hazards
- Fire
- Mechanical and heat hazards
- Radiation hazards
- Chemical hazards

On-board DC/DC converters, Power interface modules and DC/DC regulators are defined as component power supplies. As components they cannot fully comply with the provisions of any safety requirements without “conditions of acceptability”. Clearance between conductors and between conductive parts of the component power supply and conductors on the board in the final product must meet the applicable safety requirements. Certain conditions of acceptability apply for component power supplies with limited stand-off (see Mechanical Information for further information). It is the responsibility of the installer to ensure that the final product housing these components complies with the requirements of all applicable safety standards and regulations for the final product.

Component power supplies for general use shall comply with the requirements in IEC/EN/UL 62368-1 or IEC/EN/UL 60950-1. Product related standards, e.g. IEEE 802.3af *Power over Ethernet*, and ETS-300132-2 *Power interface at the input to telecom equipment, operated by direct current (dc)* are based on IEC/EN/UL 60950-1 with regards to safety.

Safety Certification

PIM 4610 and PIM 4710 are UL 62368-1 recognized and certified in accordance with EN 62368-1. The flammability rating for all construction parts of the products meet requirements for V-0 class material according to IEC 60695-11-10, *Fire hazard testing, test flames – 50 W* horizontal and vertical flame test methods.

PIM 4610 and PIM 4710 meet all requirements for basic insulation according to IEC/EN/UL 62368-1:

- between input and management power output
- between input and shelf ground
- between management power output and shelf ground

The conditions of acceptability are described in the following sub document: [1/09830-BMR 455 40](#)

PIM 4010 series Power Interface Module Input 36-75 V, Output up to 20 A / 780-1080 W	28701-BMR455 40 Rev C November 2017
	© Flex

Absolute Maximum Ratings

Characteristics		min	typ	max	Unit
T _{P2}	Operating Temperature (see Thermal Consideration section)	-40		+105	°C
T _S	Storage temperature	-40		+125	°C
V _I	Input voltage	-75		75	V
V _I	Input voltage, reverse polarity. See Note 1.			75	V
V _I	Input voltage transient ANSI T1.315-2001 (R2006)			100	V
V _I	Common mode surge pulses (1.2/50 μs) IEC 61000-4-5			500	V
V _{ISO}	Isolation voltage, shelf ground to main unit			2000	Vdc
	Isolation voltage, shelf ground to management power			2000	
	Isolation voltage, main unit to management power			2000	
V _{HU}	Hold up capacitor voltage			100	V
C _{HU}	Hold up capacitor capacitance			6600	μF
V _{IN2}	External supply voltage			16	V
I _{ALARM}	Alarm sink current			135	mA
V _{ALARM}	Alarm open drain voltage			100	V
I _{PG}	Power good sink current			100	mA
V _{PG}	Power good, open collector voltage			120	V
V _{SCL} , V _{SDA}	SCL and SDA voltage	-0.5		6	V

Stress in excess of Absolute Maximum Ratings may cause permanent damage. Absolute Maximum Ratings, sometimes referred to as no destruction limits, are normally tested with one parameter at a time exceeding the limits in the Electrical Specification. If exposed to stress above these limits, function and performance may degrade in an unspecified manner.

Note 1: The voltage between +IN A and +IN B must be less than 100 V and the voltage between -IN A and -IN B must be less than 120 V.

Fundamental Circuit Diagram

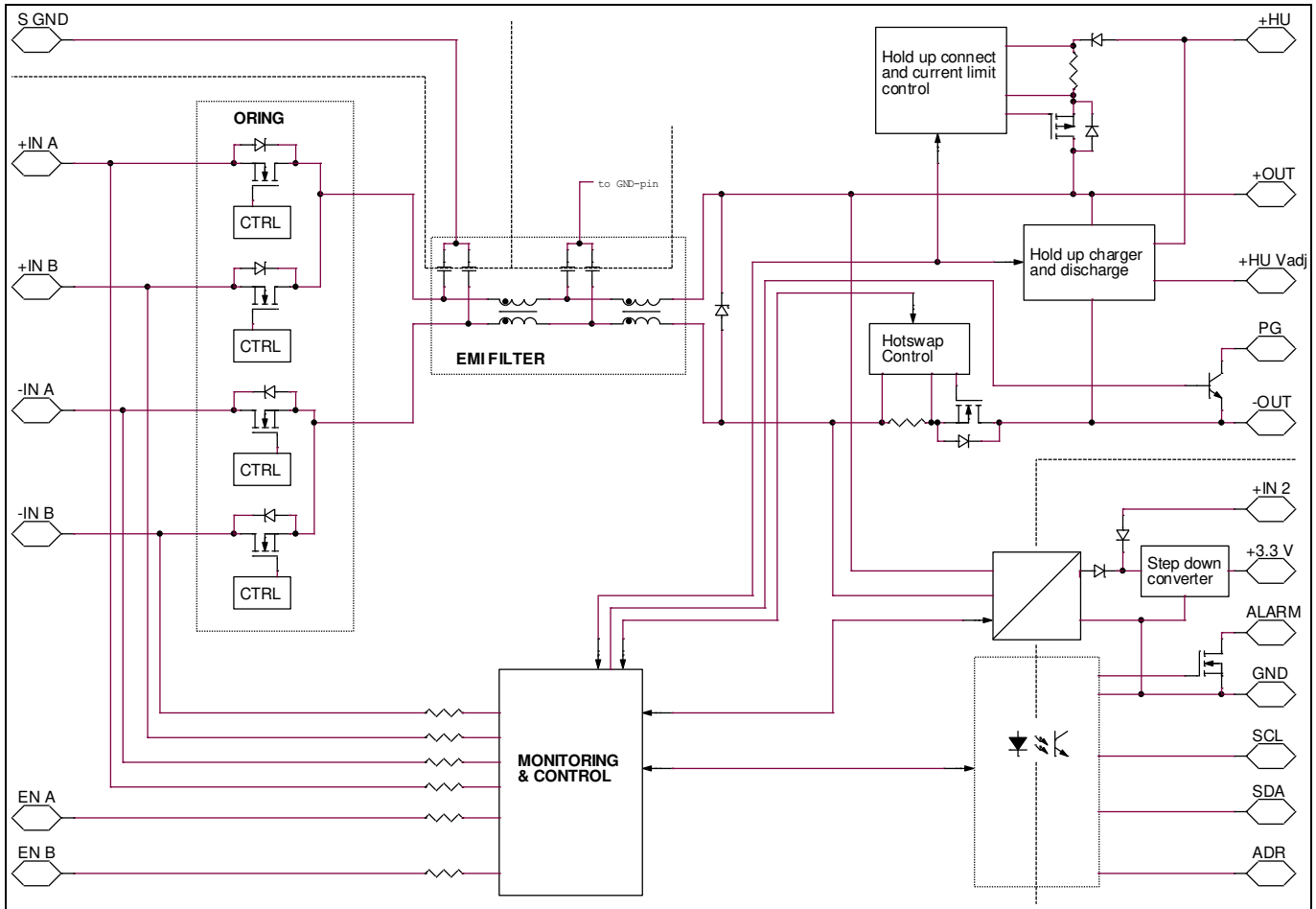

Technical Specification

PIM 4010 series Power Interface Module Input 36-75 V, Output up to 20 A / 780-1080 W	28701-BMR455 40 Rev C November 2017
	© Flex

Main Unit (Output 1), Electrical Specification

PIM 4610 / PIM 4710

$T_{P1} = -40$ to 90 °C, $V_1 = 36$ to 72 V, $C_{O1} = 470$ μ F/38 m Ω electrolytic + 15 μ F ceramic, $C_{O2} = 2 \times 100$ μ F ceramic (see Note 5), unless otherwise specified under Conditions.

Typical values given at: $T_{P1} = +25$ °C, $V_1 = 53$ V, max I_{O1} , $I_{O2} = 3.6$ A, unless otherwise specified under Conditions.

Characteristics		Conditions	min	typ	max	Unit
V_1	Input voltage range		36	53	72	V
$V_{I A/B \text{ off}}$	Turn-off threshold voltage	Decreasing feed A and B voltage	32	33		V
$V_{I A/B \text{ on}}$	Turn-on threshold voltage	Increasing feed A or B voltage		35	36	V
$I_{EN A/B}$	Enable input current			120	200	μ A
C_1	Internal input capacitance	$V_1 = 0$ V		40		μ F
η	Efficiency	P _{O1} = 600 W, I _{O2} = 0 A	PIM 4610		98.8	%
				I _{O1} = 16 A, I _{O2} = 0 A	98.5	
				I _{O1} = 16 A, I _{O2} = 3.6 A	98.2	
		P _{O1} = 780 W, I _{O2} = 0 A	PIM 4710		98.8	
				I _{O1} = 20 A, I _{O2} = 0 A	98.5	
				I _{O1} = 20 A, I _{O2} = 3.6 A	98.2	
Pd	Power Dissipation	I _{O1} = 16 A, I _{O2} = 3.6 A	PIM 4610	16	21	W
		I _{O1} = 20 A, I _{O2} = 3.6 A	PIM 4710	20	27	
P _{li}	Input idling power	$V_1 = 53$ V, $I_{O1} = I_{O2} = 0$ A		1.8		W
I_{UVLO}	Input standby current	$V_1 < V_{I A/B \text{ off}}$			24	mA
t_r	Ramp-up time (from 10–90 % of V_{O1})	$I_{O1} = I_{O2} = 0$ A.	PIM 4610	70		ms
			PIM 4710	45		
t_s	Start-up time (from V_1 connection to 90 % of V_{O1})		PIM 4610	250	435	ms
			PIM 4710	225	360	
I_{O1}	Output current	see Note 2	PIM 4610	0	16	A
			PIM 4710	0	20	
I_{lim}	Current limit threshold	$T_{P1} < \max T_{P1}$	PIM 4610	20	20.5	A
			PIM 4710	24.5	25	
I^2t	E-Fuse rating	$I_{O1} > I_{lim}$			100	A ² s
I_{sc}	Short circuit current	$T_{P1} = 25$ °C, see Note 3		0.1		A
C_{O1}	Recommended Capacitive Load	$T_{P1} = 25$ °C, see Note 4	100		600	μ F
I_{PK}	Inrush current transient	$T_{P1} = 25$ °C			7	A

Note 2: No load allowed at start-up, see Hot Swap Functionality section

Note 3: Average current, hiccup mode over current protection

Note 4: See Hold Up Event Voltage section

Note 5: The stated value is the rated capacitance. With 3.3 V bias applied and with the particular frequency and amplitude of the ripple voltage the capacitance of the ceramic capacitors is approximately 50% lower than the rated value.

Technical Specification

PIM 4010 series Power Interface Module Input 36-75 V, Output up to 20 A / 780-1080 W	28701-BMR455 40 Rev C November 2017
	© Flex

Hold up, Electrical Specification**PIM 4610 / PIM 4710**

$T_{P1} = -40$ to 90 °C, $V_1 = 36$ to 72 V, $C_{O1} = 470$ μ F/38 m Ω electrolytic + 15 μ F ceramic,

$C_{O2} = 2 \times 100$ μ F ceramic (see Note 5), unless otherwise specified under Conditions.

Typical values given at: $T_{P1} = +25$ °C, $V_1 = 53$ V, max I_{O1} , $I_{O2} = 3.6$ A, unless otherwise specified under Conditions.

Characteristics		Conditions	min	typ	max	Unit
C_{HU}	Hold up capacitance	See Hold Up Safe Operating Area			6600	μ F
f_{HU}	Hold up generator switching frequency			500		kHz
V_{HU}	Hold up capacitor voltage adjust range		40		95	V
t_{HU}	Hold up time	$C_{HU} = 3340$ μ F, $V_{HU} = 75$ V, $P_{O1} = 600$ W, $I_{O2} = 3.6$ A		10		ms
V_{HU_TRIG}	Input / output voltage threshold for hold up event			36.8		V
V_{HU_OVP}	Hold up over voltage protection			100		V
I_{HU}	Hold up charger current	$V_{HU} = 75$ V		10		mA
	Hold up charger short circuit current			80		
	Hold up dump current	$V_{HU} > V_{O1}$				A
				PIM 4610	50	
				PIM 4710	80	

Alarm and Power Good, Electrical Specification

$T_{P1} = -40$ to 90 °C, $V_1 = 36$ to 72 V, $C_{O1} = 470$ μ F/38 m Ω electrolytic + 15 μ F ceramic,

$C_{O2} = 2 \times 100$ μ F ceramic (see Note 5), unless otherwise specified under Conditions.

Typical values given at: $T_{P1} = +25$ °C, $V_1 = 53$ V, max I_{O1} , $I_{O2} = 3.6$ A, unless otherwise specified under Conditions.

Characteristics		Conditions	min	typ	max	Unit
V_1	Input voltage alarm threshold	Normal conditions, increasing feed A and B voltages		38.4		V
		Fault conditions, decreasing feed A or B voltages		36.9		
V_{ALARM_OL}	Alarm low level output voltage	$I_{ALARM} = 20$ mA. Referenced to GND.			0.4	V
I_{ALARM_OH}	Alarm high level output current	$V_{ALARM} = 5.0$ V. Referenced to GND.			10	μ A
V_{PG_OL}	Power good low level output voltage	$I_{PG} = 8$ mA. Referenced to -OUT.			0.4	V
I_{PG_OH}	Power good high level output current	$V_{PG} = 5.0$ V. Referenced to -OUT.			10	μ A

Technical Specification

PIM 4010 series Power Interface Module Input 36-75 V, Output up to 20 A / 780-1080 W	28701-BMR455 40 Rev C November 2017
	© Flex

Management Power (Output 2), Electrical Specification**PIM 4610 / PIM 4710**

$T_{P3} = -40$ to 90 °C, $V_1 = 36$ to 72 V, $C_{O1} = 470$ μ F/38 m Ω electrolytic + 15 μ F ceramic,

$C_{O2} = 2 \times 100$ μ F ceramic (see Note 5), unless otherwise specified under Conditions.

Typical values given at: $T_{P3} = +25$ °C, $V_1 = 53$ V, max I_{O1} , $I_{O2} = 3.6$ A, unless otherwise specified under Conditions.

Characteristics		Conditions	min	typ	max	Unit
$V_{I\ A/B\ off}$	Turn-off threshold voltage	Decreasing feed A and B voltage	32	33		V
$V_{I\ A/B\ on}$	Turn-on threshold voltage	Increasing feed A or B voltage		35	36	V
V_{IN2}	External supply voltage		9	12	13.2	V
η	Efficiency	No external supply, $I_{O1} = 0$ A, $I_{O2} = 3.6$ A, see Note 6		71.9		%
		$V_{IN2} = 12$ V, $I_{O1} = 0$ A, $I_{O2} = 3.6$ A, see Note 7		88.9		
		$V_{IN2} = 12$ V, $I_{O1} = 0$ A, $I_{O2} = 7$ A, see Note 7		85.2		
P_d	Power Dissipation	No external supply, $I_{O1} = 0$ A, $I_{O2} = 3.6$ A, see Note 6		4.7	5.9	W
		$V_{IN2} = 12$ V, $I_{O1} = 0$ A, $I_{O2} = 3.6$ A, see Note 7		1.5	1.7	
		$V_{IN2} = 12$ V, $I_{O1} = 0$ A, $I_{O2} = 7$ A, see Note 7		4.0	4.9	
V_{O1}	Output voltage initial setting and accuracy	$T_{P1} = +25$ °C, $V_1 = 53$ V, $I_{O2} = 1.8$ A	3.27	3.33	3.38	V
V_O	Output voltage tolerance band	no external supply, $I_{O2} = 0$ to 3.6 A or $V_{IN2} = 9$ to 13.2 V, $I_{O2} = 0$ to 7 A	3.2		3.4	V
	Idling voltage	$I_{O2} = 0$ A	3.27	3.33	3.4	V
	Line regulation	$V_1 = 36$ to 72 V, $I_{O2} = 3.6$ A		1		mV
	Load regulation	$V_1 = 53$ V, no external supply, $I_{O2} = 0...3.6$ A			11	
$V_1 = 53$ V, $V_{IN2} = 12$ V, $I_{O2} = 0...7$ A				15		
V_{tr}	Load transient voltage deviation	$V_1 = 53$ V, no external supply, Load step $I_{O2} = 0.75-2.25-0.75$ A, $di/dt = 1$ A/ μ s, $C_{O2} = 6 \times 100$ μ F ceramic, see Note 5		± 75		mV
		$V_1 = 53$ V, $V_{IN2} = 12$ V, Load step $I_{O2} = 1.75-5.25-1.75$ A, $di/dt = 1$ A/ μ s, $C_{O2} = 470$ μ F/10 m Ω OS-CON + 4×100 μ F ceramic, see Note 5		± 100		
t_{tr}	Load transient recovery time			75		μ s
t_r	Ramp-up time (from 10-90 % of V_{O1})			3		ms
t_s	Start-up time (from V_1 connection to 90 % of V_{O1})			70		ms
I_O	Output current	Continuous output current, without external supply	0		3.6	A
		Continuous output current, with external supply	0		7	
I_{lim}	Current limit threshold	$T_{P3} < \max T_{P3}$, no external supply		4.5	5.5	A
		$T_{P3} < \max T_{P3}$, $V_{IN2} = 12$ V		10	11.5	
I_{sc}	Short circuit current	$T_{P3} = 25$ °C		10	12.5	A
C_{O2}	Recommended Capacitive Load		100		4700	μ F
V_{Oac}	Output ripple & noise	See Output ripple & noise section, $I_O = 3.6$ A		6		mV _{p-p}
f_s	Switching frequency	First stage		510		kHz
		Second stage		480		

Note 6: Idling losses in main unit are included

Note 7: Idling losses in main unit are not included

Technical Specification

PIM 4010 series Power Interface Module Input 36-75 V, Output up to 20 A / 780-1080 W	28701-BMR455 40 Rev C November 2017
	© Flex

Functional Description

PIM 4610, PIM 4710

$T_{P1} = -40$ to 90 °C, $V_1 = 36$ to 72 V, $C_{O1} = 470$ μ F/38 m Ω electrolytic + 15 μ F ceramic, $C_{O2} = 2 \times 100$ μ F ceramic (see Note 5), unless otherwise specified under Conditions.
 Typical values given at: $T_{P1} = +25$ °C, $V_1 = 53$ V, max I_{O1} , $I_{O2} = 3.6$ A, unless otherwise specified under Conditions.

Characteristics		Comments	min	typ	max	Unit
PMBus monitoring accuracy						
READ_VIN	OR'ed input voltage	$V_1 = 36$ V to 75 V	-1.5	± 0.25	1.5	%
MFR_READ_VINA	Feed A input voltage	$V_1 = 0$ V to 36 V	-0.5		0.5	V
MFR_READ_VINB	Feed B input voltage					
READ_VCAP	Hold up capacitor voltage	$V_{HU} = 50$ V to 95 V	-3	± 1	3	%
READ_IIN	OR'ed input current	$I_{O1} = 0$ A to 16 A	-0.3	± 0.1	0.3	A
READ_IOUT		$I_{O2} = 0$ A to 3.6 A				
READ_PIN	Input power	$P_1 = 300$ W to 600 W	-3.5	± 1	3.5	%
		$P_1 = 0$ W to 300 W				
		$P_1 = 390$ W to 780 W	-3.5	± 1	3.5	%
		$P_1 = 0$ W to 390 W				
READ_TEMPERATURE_1	P3 temperature	$T_{P3} = 25$ to 90 °C	-5	± 3	5	°C
Fault Protection Characteristics						
UVLO, input under voltage lockout	Delay			100		ms
OCP, over current protection	Fault response time	$I_{O1} = 25$ A		95		ms
		$I_{O1} = 32$ A		2		
OTP, over temperature protection, position P2	Trip limit			105		°C
	Hysteresis			10		°C
	Fault response time				1	s

Logic Input/Output Characteristics						
PMBus frequency			10		400	kHz
Logic input low (V_{IL})	SCL, SDA				0.96	V
Logic input high (V_{IH})			2.38			
Logic output low (V_{OL})					0.4	
Setup time, SMBus			460			ns
Hold time, SMBus			210			
Bus free time (T_{BUF})	Note 8	After read access	1.3			μ s
		After write access	30			

Note 8: It is recommended that a PMBus master reads back written data for verification.

PIM 4010 series Power Interface Module
 Input 36-75 V, Output up to 20 A / 780-1080 W

28701-BMR455 40 Rev C November 2017
 © Flex

Main Unit (Output 1), Typical Characteristics

Efficiency (PIM 4610)

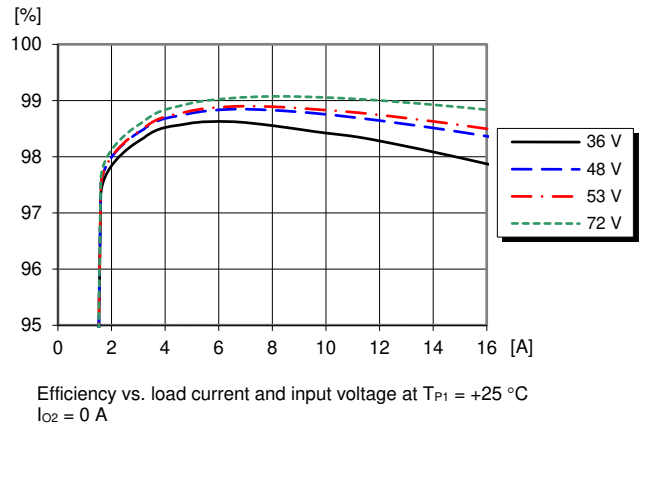

Efficiency (PIM 4710)

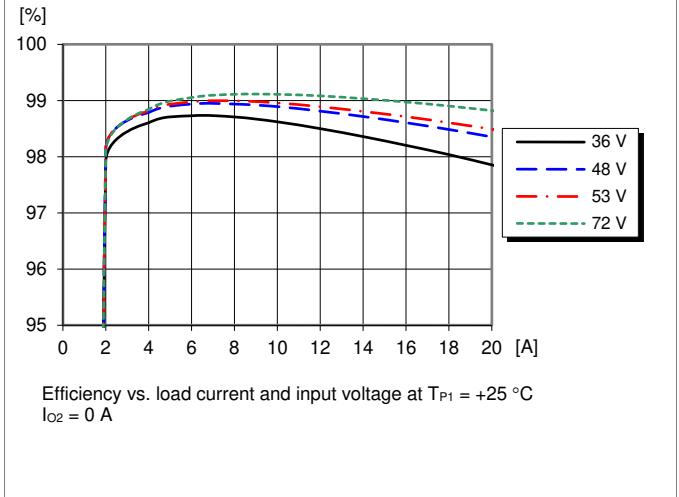

Power Dissipation (PIM 4610)

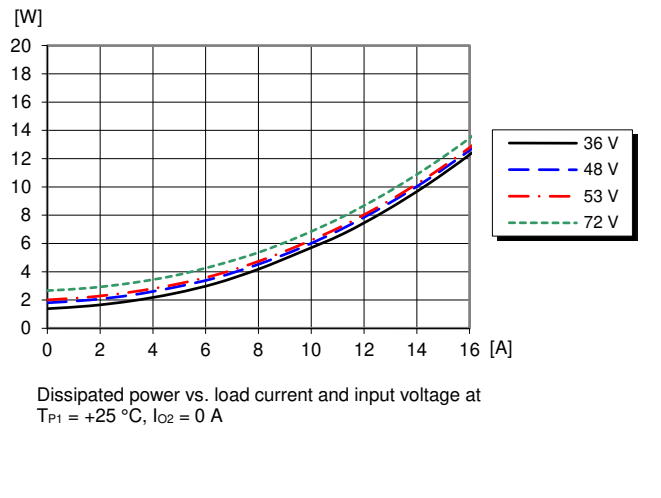

Power Dissipation (PIM 4710)

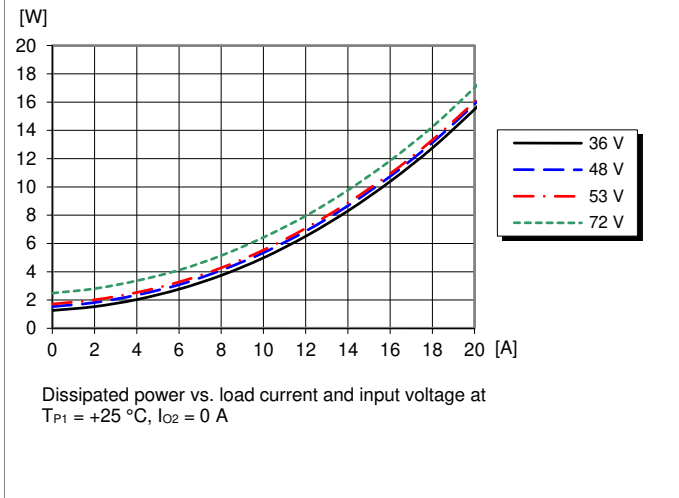

Output Current Derating, no external supply (PIM 4610)

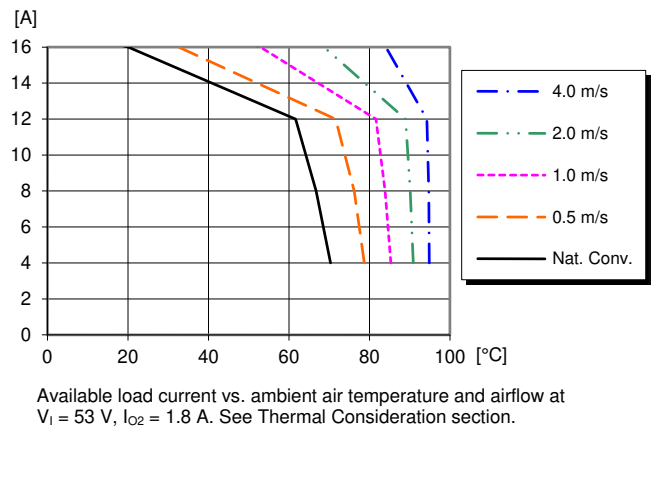

Output Current Derating, no external supply (PIM 4710)

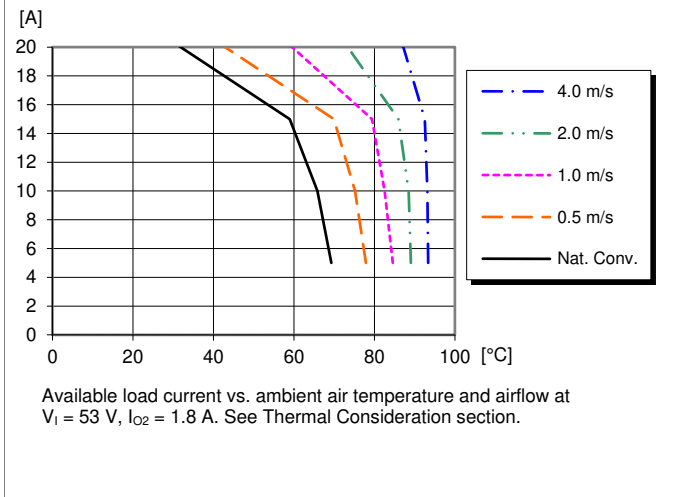

Technical Specification

PIM 4010 series Power Interface Module Input 36-75 V, Output up to 20 A / 780-1080 W	28701-BMR455 40 Rev C November 2017
	© Flex

Main Unit (Output 1), Typical Characteristics

Output Current Derating, external 12 V supply (PIM 4610)

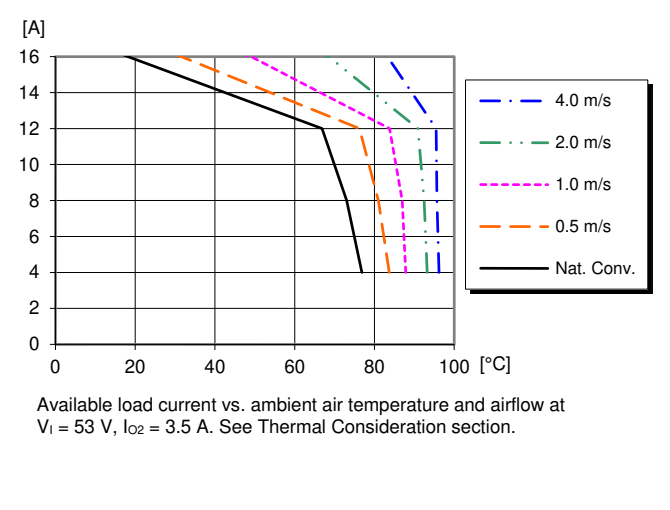

Output Current Derating, external 12 V supply (PIM 4710)

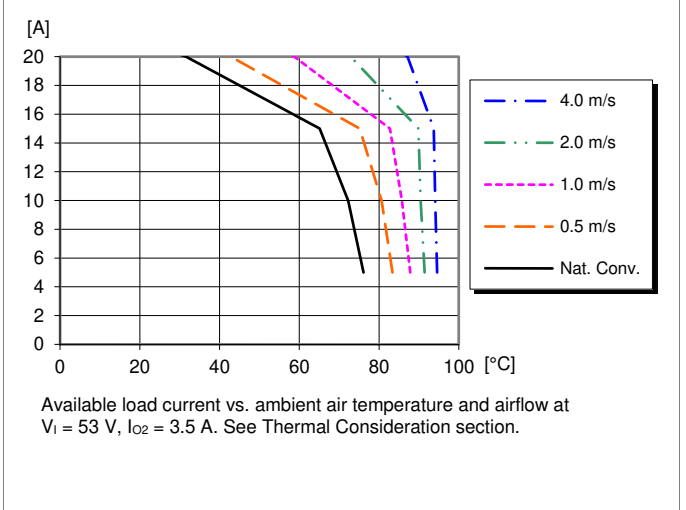

Ramp-up (PIM 4610)

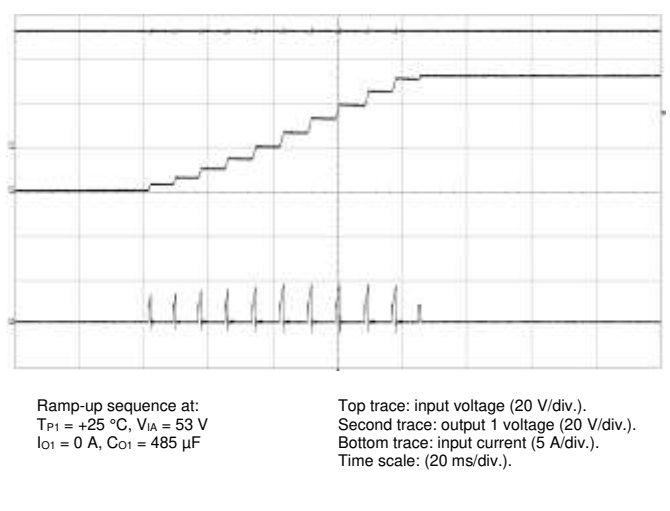

Ramp-up (PIM 4710)

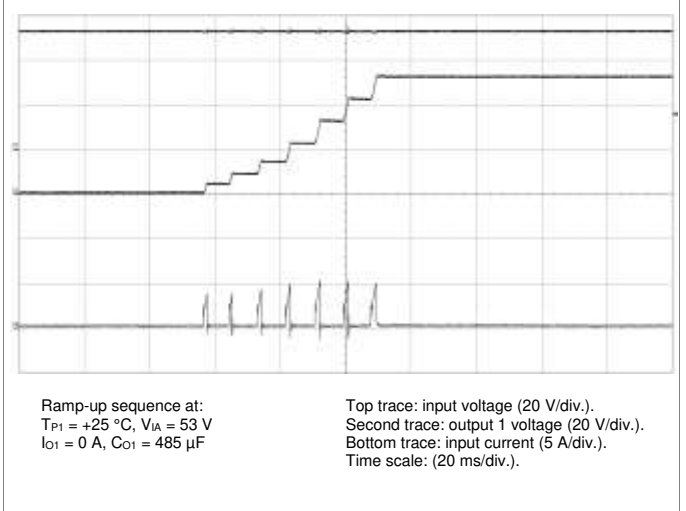

Start-up sequence

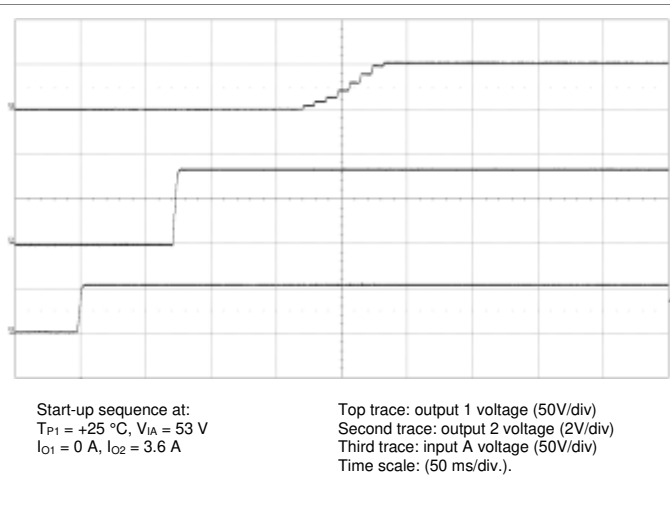

Hold up performance

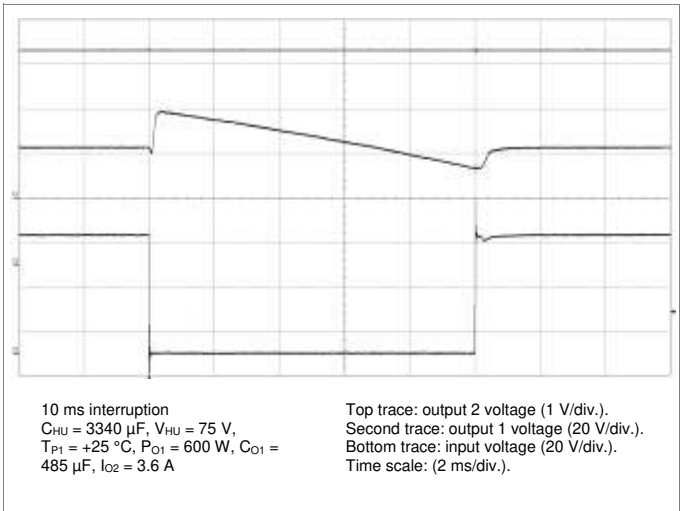

Technical Specification

PIM 4010 series Power Interface Module
 Input 36-75 V, Output up to 20 A / 780-1080 W

28701-BMR455 40 Rev C November 2017
 © Flex

Management Power (Output 2), Typical Characteristics

PIM 4610, PIM 4710

Output Characteristics

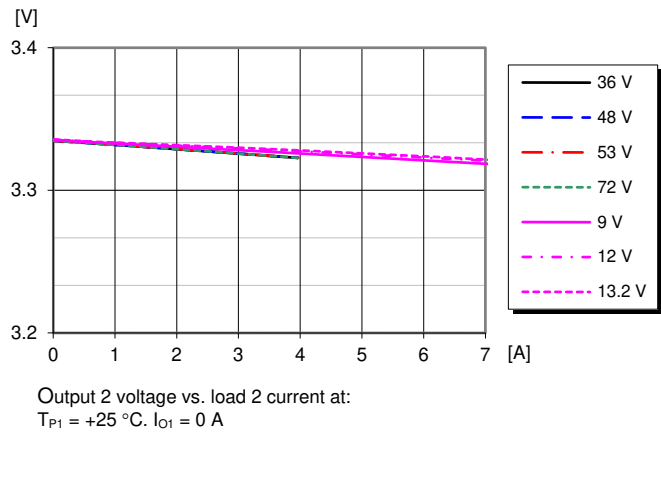

Power Dissipation

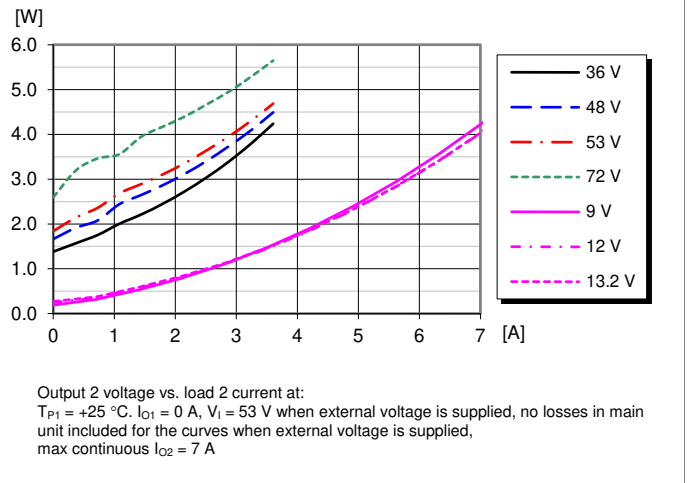

Output Current Derating, no external supply

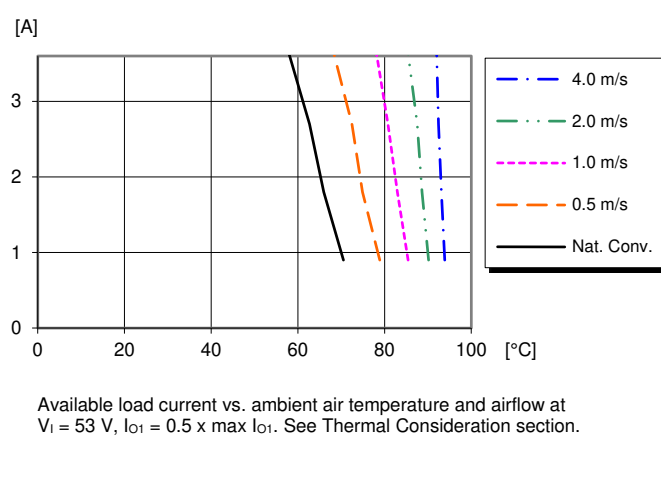

Output Current Derating, external 12 V supply

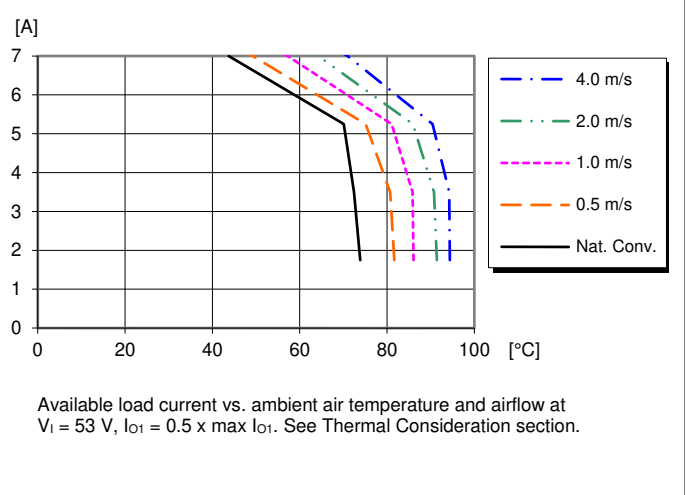

Output Current Limit Characteristic, no external supply

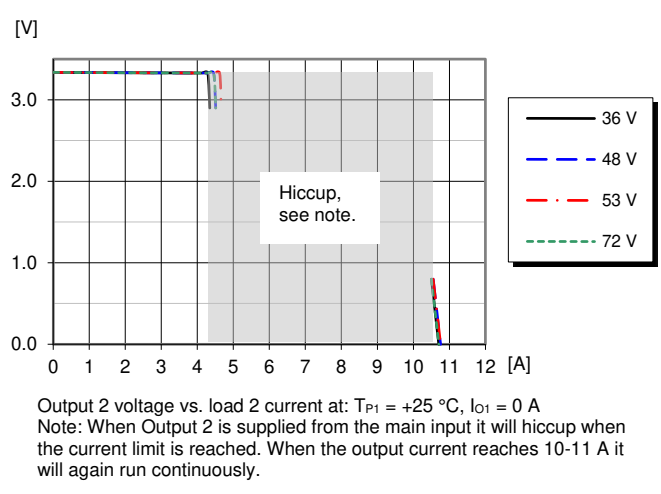

Output Current Limit Characteristic, external supply

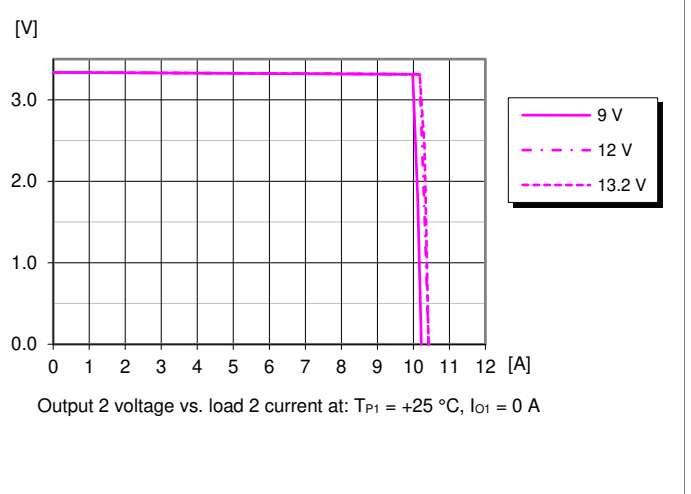

Technical Specification

PIM 4010 series Power Interface Module Input 36-75 V, Output up to 20 A / 780-1080 W	28701-BMR455 40 Rev C November 2017
	© Flex

Ramp-up

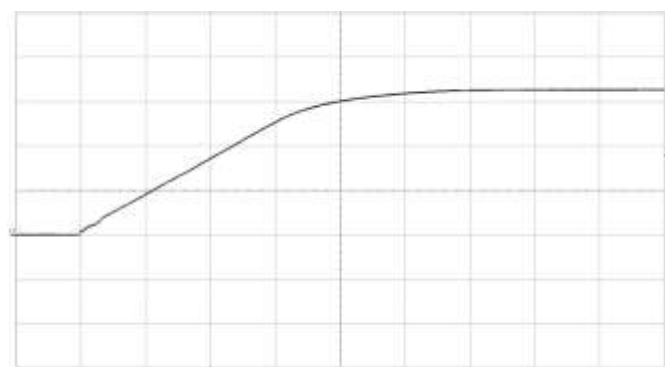

$T_{P1} = +25\text{ }^{\circ}\text{C}$, $V_1 = 53\text{ V}$,
 $I_{O1} = 0\text{ A}$, $I_{O2} = 3.6\text{ A}$, $C_{O2} = 360\text{ }\mu\text{F}$
 Top trace: output 2 voltage (1 V/div.).
 Time scale: (1 ms/div.).

Shut-down

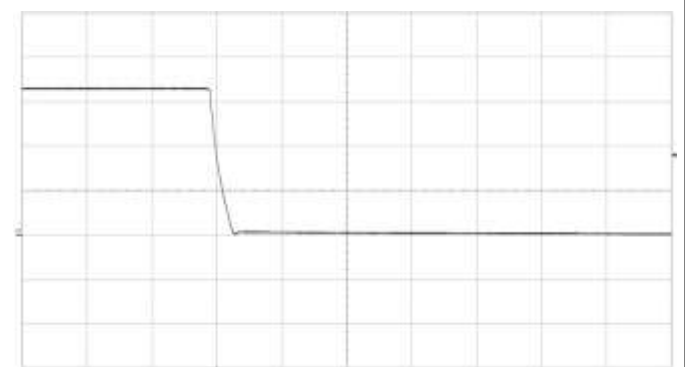

$T_{P1} = +25\text{ }^{\circ}\text{C}$, $V_1 = 53\text{ V}$,
 $I_{O1} = 0\text{ A}$, $I_{O2} = 3.6\text{ A}$, $C_{O2} = 360\text{ }\mu\text{F}$
 Top trace: output 2 voltage (1 V/div.).
 Time scale: (1 ms/div.).

Output Load Transient Response

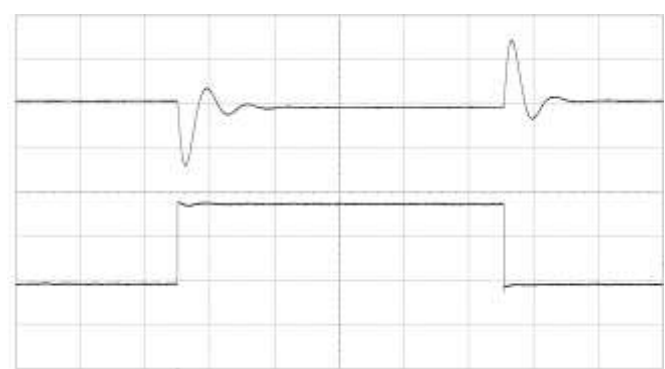

Output voltage response to load current
 step-change, output 2 (0.9-2.7-0.9 A)
 at: $T_{P1} = +25\text{ }^{\circ}\text{C}$, $V_1 = 53\text{ V}$
 $I_{O1} = 0\text{ A}$, electronic load,
 $C_{O2} = 6 \times 100\text{ }\mu\text{F}$ (see Note 5)
 Top trace: output 2 voltage (50 mV/div.).
 Bottom trace: output 2 current (1 A/div.).
 Time scale: (0.2 ms/div.).

Output 2 Ripple & Noise

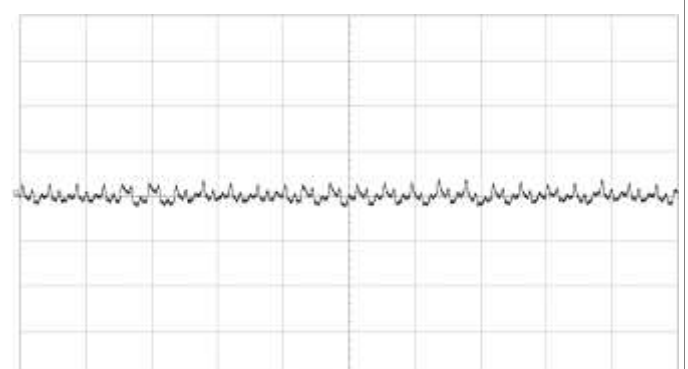

Output voltage ripple at:
 $T_{P1} = +25\text{ }^{\circ}\text{C}$, $V_1 = 53\text{ V}$,
 $I_{O1} = 0\text{ A}$, $I_{O2} = 3.6\text{ A}$, resistive load
 Output 2 voltage (10 mV/div.).
 Time scale: (100 μs /div.).

Technical Specification

PIM 4010 series Power Interface Module
Input 36-75 V, Output up to 20 A / 780-1080 W

28701-BMR455 40 Rev C November 2017

© Flex

Typical ATCA Application Circuit

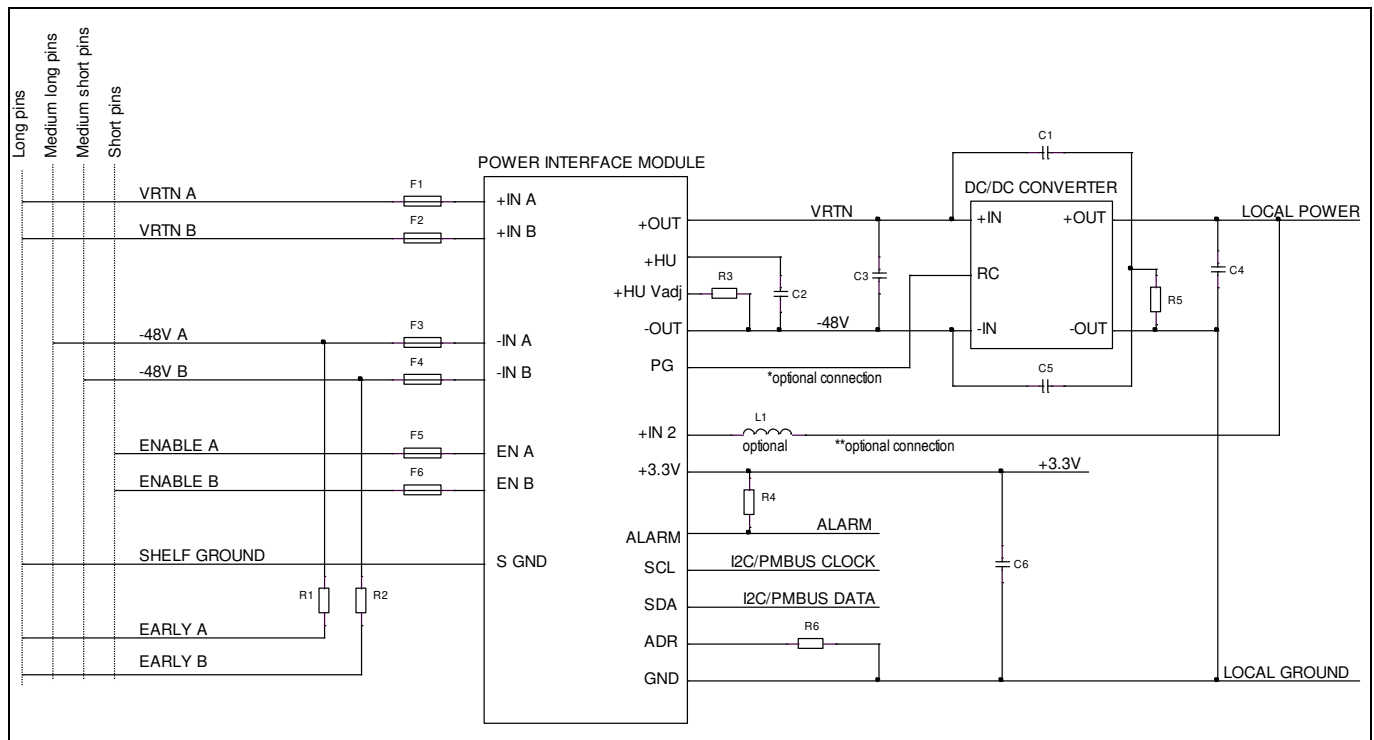

External components

C1, C5 = EMI suppression capacitor (recommended 30 nF)

C2 = hold up capacitor, C_{HU} (max 6600 μ F)

C3 = DC/DC converter input capacitor, C_{O1} (see technical specification of the DC/DC converter)

C4 = DC/DC converter output capacitor (see technical specification of the DC/DC converter)

C6 = management power output capacitor, C_{O2} (recommended 360 μ F)

F1 = fuse (recommended >25 A)

F2 = fuse (recommended >25 A)

F3 = fuse (recommended >25 A)

F4 = fuse (recommended >25 A)

F5 = fuse (recommended 0.5 A)

F6 = fuse (recommended 0.5 A)

L1 = optional filter inductor (recommended 1 μ H to comply with class B when supplying +IN 2 from LOCAL_POWER)

R1, R2 = pre-charge resistor (recommended 50 Ω , max 1 A, max 50 ms)

R3 = hold up voltage adjust resistor, R_{HU} (see Hold Up Capacitor Charge section)

R4 = alarm pull-up resistor (recommended 3.3 k Ω)

R5 = EMI suppression resistor (recommended 0 Ω)

R6 = PMBus Address configuration resistor (see PMBus Addressing section)

* The RC-pin of the DC/DC Converter may be controlled by an IPM in which case the connection to the PG-pin of the PIM shall be removed. (IPM = Intelligent Platform Management (see ATCA specification PICM 3.7)). The DC/DC must be kept off during start-up to allow the PIM to charge the capacitance, C3.

** The connection between LOCAL_POWER and +IN 2 is optional. With this connection the +3.3 V output can deliver higher current.

Technical Specification

PIM 4010 series Power Interface Module Input 36-75 V, Output up to 20 A / 780-1080 W	28701-BMR455 40 Rev C November 2017
	© Flex

EMC Specification

The product contains an EMI filter which is designed to meet the requirements according to EN 55022, CISPR 22 and FCC part 15J class B (see test set up), when used in conjunction with Flex PKM 4613ANH DC/DC converter, PKM 4817NH DC/DC converter and two BMR 456 0004 DC/DC converters in parallel. PIM 4710 and PIM 4610 have the same filter.

Conducted EMI Input terminal peak value (typ)

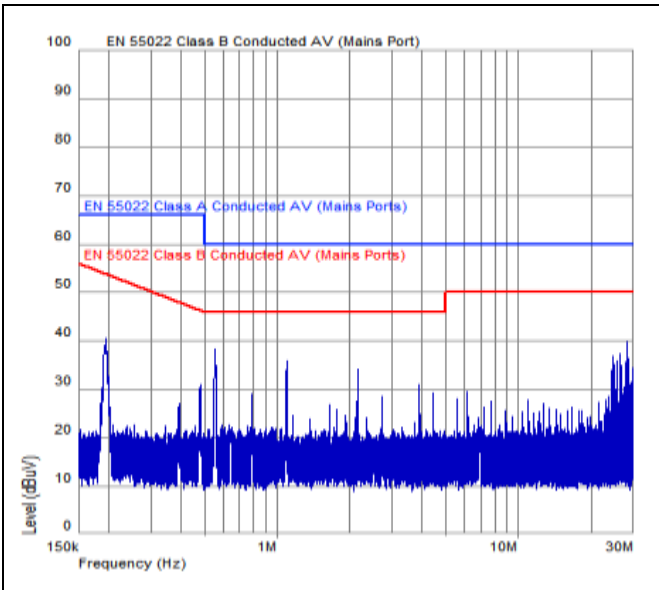

in combination with PKM 4613ANH
 $V_I = 48\text{ V}$, $C_{O1} = 330\ \mu\text{F}$ electrolytic // $130\ \mu\text{F}$ ceramic, $I_{O1} \approx 13\text{ A}$
 $(I_{O_DC/DC} = 50\text{ A})$, $I_{O2} = 3.6\text{ A}$

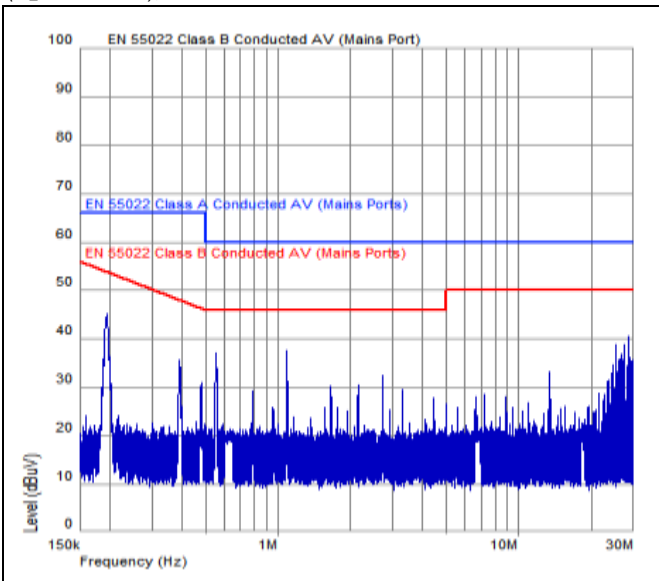

in combination with PKM 4613ANH
 $V_I = 60\text{ V}$, $C_{O1} = 330\ \mu\text{F}$ electrolytic // $130\ \mu\text{F}$ ceramic, $I_{O1} \approx 10.5\text{ A}$
 $(I_{O_DC/DC} = 50\text{ A})$, $I_{O2} = 3.6\text{ A}$

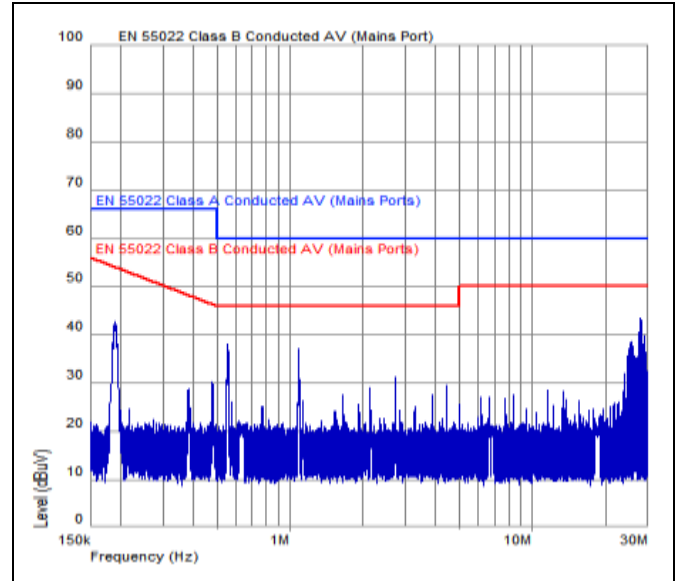

in combination with PKM 4817NH
 $V_I = 53\text{ V}$, $C_{O1} = 330\ \mu\text{F}$ electrolytic // $130\ \mu\text{F}$ ceramic, $I_{O1} \approx 17\text{ A}$
 $(I_{O_DC/DC} \approx 75\text{ A})$, $I_{O2} = 3.6\text{ A}$

Technical Specification

PIM 4010 series Power Interface Module
 Input 36-75 V, Output up to 20 A / 780-1080 W

28701-BMR455 40 Rev C November 2017
 © Flex

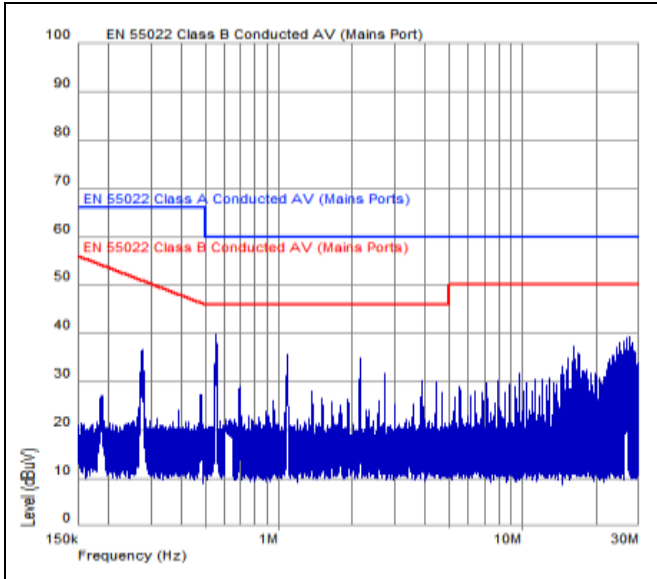

in combination with 2 x BMR 456 0004
 $V_1 = 48\text{ V}$, $C_{O1} = 470\text{ }\mu\text{F}$ electrolytic // $30\text{ }\mu\text{F}$ ceramic, $I_{O1} \approx 17\text{ A}$
 $(I_{O_DC/DC} = 2 \times 32\text{ A})$, $I_{O2} = 3.6\text{ A}$

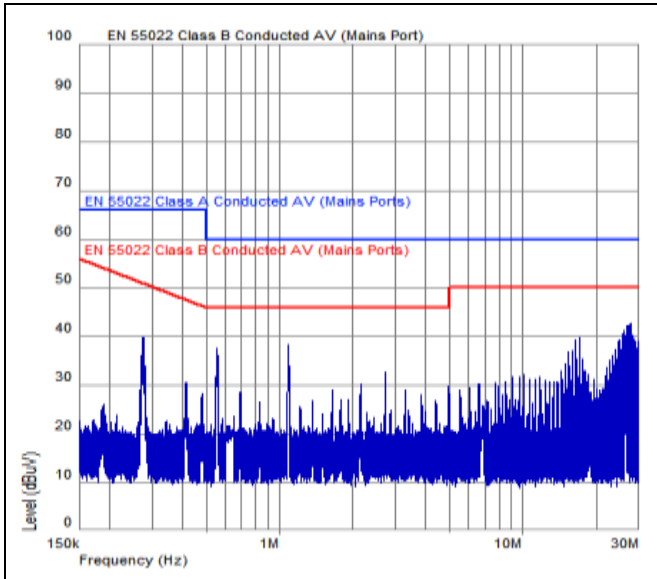

in combination with 2 x BMR 456 0004
 $V_1 = 60\text{ V}$, $C_{O1} = 470\text{ }\mu\text{F}$ electrolytic // $30\text{ }\mu\text{F}$ ceramic, $I_{O1} \approx 14\text{ A}$
 $(I_{O_DC/DC} = 2 \times 32\text{ A})$, $I_{O2} = 3.6\text{ A}$

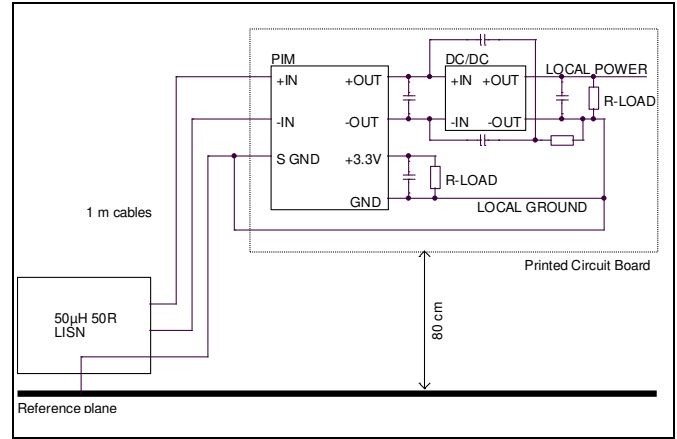

Conducted EMI Test set-up.

Layout recommendations

The radiated EMI performance of the product will depend on the PCB layout and ground layer design. It is also important to consider the stand-off of the product.

A ground layer will increase the stray capacitance in the PCB and improve the high frequency EMC performance. For more information, see the technical specification of the downstream DC/DC converter.

Output Ripple and Noise

Output ripple and noise are measured according to figure below. A 50 mm conductor works as a small inductor forming together with the two capacitances a damped filter.

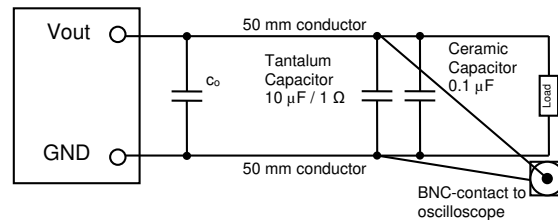

Output ripple and noise test set-up.

Technical Specification

PIM 4010 series Power Interface Module
Input 36-75 V, Output up to 20 A / 780-1080 W

28701-BMR455 40 Rev C November 2017

© Flex

I²C / PMBus Interface

This product provides an I²C/PMBus digital interface that enables the user to monitor the input and hold up voltages, output current and device temperature. The product is available in a PMBus-version (PD-suffix) and an I²C-version (PDA-suffix). The product can be used with any standard two-wire I²C or SMBus host device. In addition, the PMBus-version of the module is compatible with PMBus version 1.2. The product supports bus clock frequencies from 10 to 400 kHz. External pull-up resistors must be added to the I²C/PMBus.

I²C / PMBus Addressing

The I²C / PMBus address should be configured with a resistor connected between ADR (pin 10) and GND (pin 13), as shown in the figure below. Recommended resistor values for hard-wiring I²C / PMBus addresses are shown in the table. 1% tolerance resistors are required.

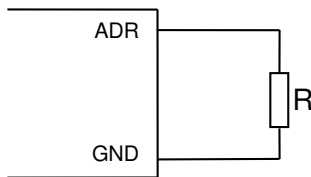

Schematic of connection of address resistor.

I ² C Address	R (Ω)
2Fh	open
2Eh	100 000
2Dh	40 200
2Ch	20 000
2Bh	10 000
2Ah	4 020
29h	2 000
28h	short

The user can configure up to 8 unique PMBus addresses.

PMBus-version (PD-suffix)

The product is PMBus compliant. A detailed description of each command is provided in the appendix at the end of this specification.

The Flex Power Designer software suite can be used to configure and monitor this product via the PMBus interface. For more information, please contact your local Flex sales representative.

Monitoring via PMBus

It is possible to continuously monitor a wide variety of parameters through the PMBus interface. These include, but are not limited to, the parameters listed in the table below.

Parameter	PMBus Command
Input voltage	READ_VIN
Total input current	READ_IIN
Output 1 current	READ_IOUT
Hold up capacitor voltage	READ_VCAP
Total input power	READ_PIN
Controller temperature	READ_TEMPERATURE_1
Feed A Input voltage	MFR_READ_VINA
Feed B Input voltage	MFR_READ_VINB

Monitoring Faults

Fault conditions can be monitored by reading a number of status commands.

Fault & Warning Status	PMBus Command
Overview, Power Good	STATUS_WORD STATUS_BYTE
Output voltage level	STATUS_VOUT
Output current level	STATUS_IOUT
Input voltage level	STATUS_INPUT
Temperature level	STATUS_TEMPERATURE
PMBus communication	STATUS_CML
Miscellaneous	STATUS_MFR_SPECIFIC

Technical Specification

PIM 4010 series Power Interface Module Input 36-75 V, Output up to 20 A / 780-1080 W	28701-BMR455 40 Rev C November 2017
	© Flex

I²C-version (PDA-suffix)

Monitoring via I²C

Via the I²C interface five analog measurements and six status bits can be read. The 8-bit values read via I²C must be multiplied by the scaling factors to get the measurement value. For the temperature reading an offset of 50 °C must be subtracted after multiplying with the scaling factor.

Designation	Data pointer	Description	Scaling factor
StatusBits	1Eh	See table StatusBits	Bit field
HU_CAP	1Fh	Hold-up capacitor voltage	0.398 V/bit
-48V_Current	21h	Output1 current	0.094 A/bit
-48V_A	22h	Feed A input voltage	0.325 V/bit
-48V_B	23h	Feed B input voltage	0.325 V/bit
Temperature	28h	Module temperature	1.961 °C/bit - 50 °C

StatusBits

A read only register that displays current status.

Designation	Bit	Function
ENABLE_A	0	Enable A signal state. 0 = Disabled. 1 = Enabled.
ENABLE_B	1	Enable B signal state. 0 = Disabled. 1 = Enabled.
ALARM	2	Alarm signal state. 0 = Feed loss alarm ceased. 1 = Feed loss alarm raised.
N/A	3	Reserved
HOLDUP	4	Hold up switch state. 0 = Hold up Capacitor is not connected to Output 1. 1 = Hold up Capacitor is connected to Output 1.
HOTSWAP	5	Hot swap switch state. 0 = Switch is off. Output 1 is off. 1 = Switch is on. Output 1 is on.
VOUT_LOW	6	Output 1 Under-Voltage Alarm. 0 = Output voltage is below threshold. 1 = Output voltage is above threshold.
N/A	7	Reserved

I²C Protocol

To read data through the I²C interface the Data pointer must first be written.

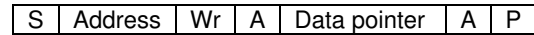

From master to slave

From slave to master

S START condition

P STOP condition

A Acknowledge / No acknowledge

If more bytes are written after the Data pointer they will be discarded but the Data pointer will be advanced the number of bytes written.

After the Data pointer has been written data can be read.

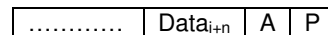
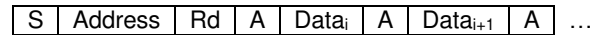

The first byte read will be the value referenced by the Data pointer. Several bytes may be read in one access. For each byte read the Data pointer will be incremented. Reading from an undefined location returns 00h.

The Data pointer is initiated to 00h at power-on and does not overflow when it reaches FFh. A write may end with a repeat START followed by a read.

Technical Specification

PIM 4010 series Power Interface Module
Input 36-75 V, Output up to 20 A / 780-1080 W

28701-BMR455 40 Rev C November 2017

© Flex

Operating information

Input Voltage

The input voltage range 36 to 72 Vdc meets the requirements of the European Telecom Standard ETS 300 132-2 for normal input voltage range in -48 and -60 Vdc systems, -40.5 to -57.0 V and -50.0 to -72 V respectively.

Input Enable

The product has two Enable inputs which shall be connected to feed A and feed B supply of the backplane. The enable pins of the ATCA board are the last to be connected during board insertion and the first to be disconnected during board exertion. The product is switched off until one enable input is connected to the supply (EN A connected to +IN A or EN B connected to +IN B).

A/B Feed OR'ing

Four MOSFETs provide OR'ing of the input feeds. If a short is detected on one of the feeds a control circuit will detect reverse current and quickly turn the MOSFETs off. This feature will also protect the product against reverse polarity of up to 75 V. At high load operation the MOSFETs are operated at a low $R_{ds(on)}$ condition and at zero load they are turned off.

A/B Feed Alarm

The input feeds A and B are monitored. In case of a feed loss the alarm pin will indicate a fault condition which is provided by an opto isolated signal. Under normal conditions the ALARM output goes low (low resistance to GND) and in case of a feed loss the ALARM output goes open drain (high voltage with a pull-up).

Management Power

The product provides one isolated DC output, 3.3 V referred to GND. The management power is available as soon as the input voltage level is within 36 V to 72 V. The output is short circuit protected. In a short circuit condition the 3.3 V output will operate in a constant current mode. A 360 μ F ceramic capacitor on the 3.3 V output is recommended to reduce switching noise and improve transient characteristics. Management power will be on for max 100 ms after enable A and B have dropped below enable turn-off threshold voltage.

Hot Swap Functionality

The hot swap function is designed to control the inrush current to the downstream DC/DC converter. The level and duration of the inrush current complies with the PICMG 3.7 ATCA base specification Inrush transient specifications. Note: The hot swap circuit limits the output 1 current during start up. Hence, output 1 cannot be loaded before its external filter capacitor has been charged.

Hold Up Function

If the voltage on both feed A and B falls below V_{HU_TRIG} (default 36.8 V) or if the output voltage (V_{O1}) falls below the same threshold a hold up event will be triggered.

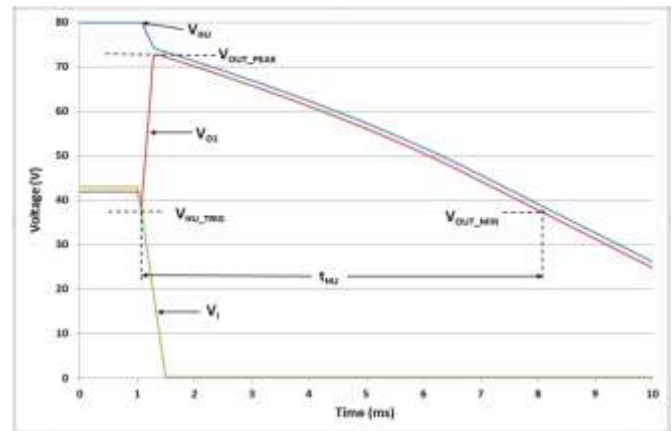

Hold Up Event

During the hold up event the external hold up capacitor C_{HU} will be connected across the output capacitor C_{O1} by a current limiter switch. During the first phase of the event the output capacitor will be charged with current from the hold up capacitor until the voltage of the two capacitors evens out (at V_{OUT_PEAK}). During the second phase of the event the two capacitors together work as an energy reservoir to provide power to downstream consumers.

If hold up is not used pin 17 and 19 can be left open.

Hold Up Voltage and Capacitor Selection

Expressions used in this section:

V_{HU} = Hold up capacitor charge voltage

C_{HU} = External hold up capacitor capacitance

C_{O1} = External capacitance on output 1

P_{OUT} = Total output power on output 1 and 2

t_{HU} = Hold up time

V_{HU_TRIG} = This is the input/output voltage threshold that triggers the hold up event.

V_{OUT_PEAK} = This is the highest voltage that the downstream consumers will be exposed to during a hold up event.

V_{OUT_MIN} = This is the minimum voltage that the downstream consumers need.

V_{O1_MAX} = This is the highest possible voltage on output 1 when the hold up event starts. Since a hold up event can be triggered either by low voltage on input or output this voltage can be as low as V_{HU_TRIG} or as high as the highest normal operating voltage on feed A and B.

Technical Specification

PIM 4010 series Power Interface Module Input 36-75 V, Output up to 20 A / 780-1080 W	28701-BMR455 40 Rev C	November 2017
	© Flex	

Hold up voltage and capacitor selection:

The hold up time is roughly proportional to the square of V_{HU} . A high V_{HU} voltage will result in a smaller hold up capacitor. Start by selecting a preliminary value for V_{HU} that is the same or a few Volts higher than the maximum allowed voltage for the downstream consumers.

Use equation 1 or diagram 1 to select a preliminary value for C_{HU} .

Diagram 1:

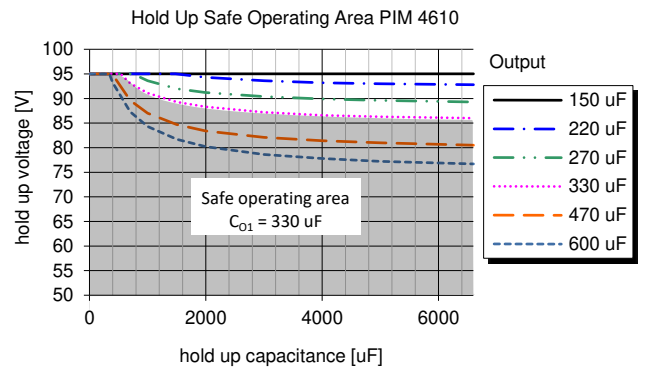
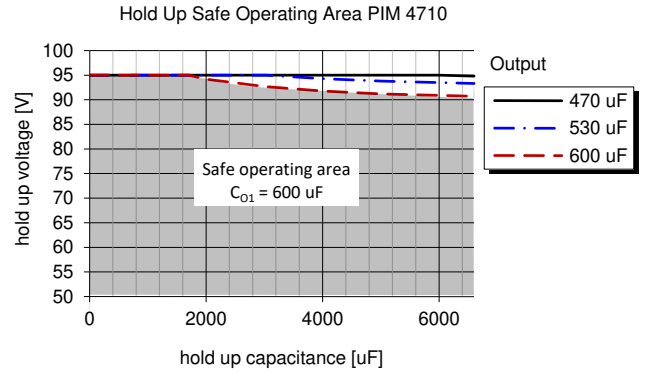
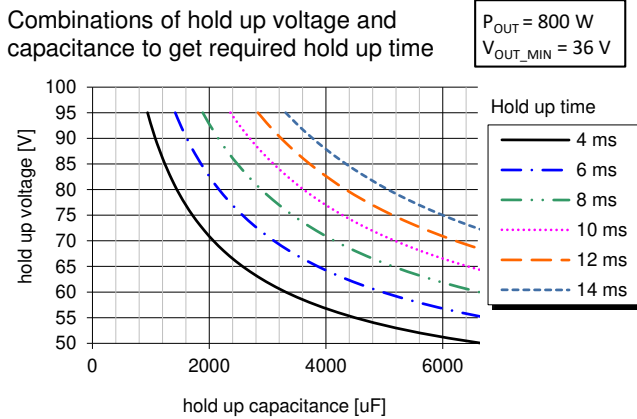

Equation 1:

$$C_{HU} \geq \frac{2.2 \times P_{OUT} \times t_{HU}}{(V_{HU} - 1.5)^2 - V_{OUT_MIN}^2} \quad [F]$$

Use equation 2 to verify that the peak voltage (V_{OUT_PEAK}) during the hold up event is lower than the maximum allowed voltage for the downstream consumers.

Equation 2:

$$V_{OUT_PEAK} = V_{O1_MAX} + (V_{HU} - V_{O1_MAX}) \times \frac{C_{HU}}{C_{HU} + C_{O1}} \quad [V]$$

If the V_{OUT_PEAK} voltage is too high select a lower V_{HU} voltage and reselect C_{HU} with equation 1 or diagram 1.

When V_{OUT_PEAK} voltage is acceptable, verify that the selected combination of values for V_{HU} , C_{HU} and C_{O1} is within the safe operating area (SOA) for the current limiter switch in the hold up circuit. If not, start from beginning and select a lower value for C_{O1} or lower V_{HU} voltage.

Hold Up Safe Operating Area

The current limiter switch in the hold up circuit is protected from over stress by a safe operating area limiting network. If the current limiter switch is operated outside its safe operating area the hold up event will be aborted.

Hold Up Capacitor Charge

An internal DC/DC converter charges the hold up capacitor to a voltage of 40 V – 95 V. The charge level is set by an external resistor.

Resistor connected between +HU V_{adj} and –OUT for hold up voltages from 50.4 to 95 V:

$$R_{HU} = \frac{480}{V_{HU} - 50.4} - 10 \quad [k\Omega]$$

where V_{HU} is the hold up voltage.

Resistor connected between +HU V_{adj} and +HU for hold up voltages from 40 to 50.4 V:

$$R_{HU} = \frac{191 \times V_{HU} - 480}{50.4 - V_{HU}} - 10 \quad [k\Omega]$$

No trim resistor results in 50.4 V hold up voltage.

Technical Specification

PIM 4010 series Power Interface Module
Input 36-75 V, Output up to 20 A / 780-1080 W

28701-BMR455 40 Rev C November 2017

© Flex

Capacitor Discharge

When the enable inputs are disconnected the hold up and output capacitor will be discharged to less than 60 V within 1 s, conditions: $V_{HU} = 75$ V, $C_{HU} = 6600$ μ F, $V_I = 60$ V, $C_{O1} = 470$ μ F.

Over Temperature Protection (OTP)

The product is protected from thermal overload by an internal over temperature shutdown circuit.

When P2 as defined in thermal consideration section exceeds 105 °C the product will shut down. The product will make continuous attempts to start up (non-latching mode) and resume normal operation automatically when the temperature has dropped > 10 °C below the temperature threshold. In an over temperature situation the management power is still available.

Input Transient Over Voltage Protection

The product incorporates a transient voltage protector which will protect the product and the downstream DC/DC converter against over voltage transients exceeding 75 V. The transient voltage protector is rated for 1.5 kW (10/1000 μ s) peak pulse power with a breakdown voltage of 83.3 V. The product also handles transients of up to 100 V for 10 μ s.

Over Current Protection (OCP)

Both the main unit (Output 1) and the management power (Output 2) of the product include current limiting circuitry for protection at continuous overload. The load distribution should be designed for the maximum output short circuit current specified.

The main unit (Output 1) will abruptly be interrupted if the output over current or an internal component overpower thresholds are exceeded for a time longer than the stated fault response time.

The output 2 voltage will decrease towards zero for output currents in excess of max output current. The product will resume normal operation after removal of the overload.

Power Good

The product has a Power Good output that by default is intended to drive the Remote Control-pin of a downstream DC/DC converter, see Typical ATCA Application Circuit. During start-up the Power Good will remain de-asserted while C_{O1} is being charged. When C_{O1} is fully charged it will assert to enable a downstream DC/DC converter. At shut down the Power Good will remain asserted.

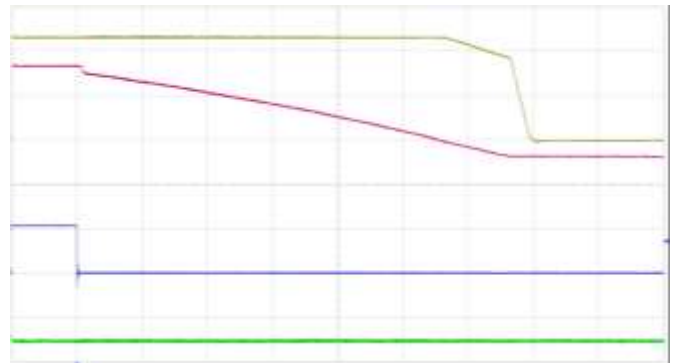

Yellow trace: DC/DC output voltage (5 V/div).
Red trace: hold up voltage (20 V/div).
Blue trace: input voltage (50 V/div).
Green trace: Power Good (5 V/div).
Time scale: (2 ms/div).

Shutdown with default configuration for Power Good.

The Power Good output can alternatively be configured to give an advance alert of a potential shutdown. This function can be used by systems that require a graceful shutdown. In this mode the Power Good will typically de-assert before the DC/DC converter has reach its under-voltage lockout. When used in this mode the Power Good shall be connected to an IPM.

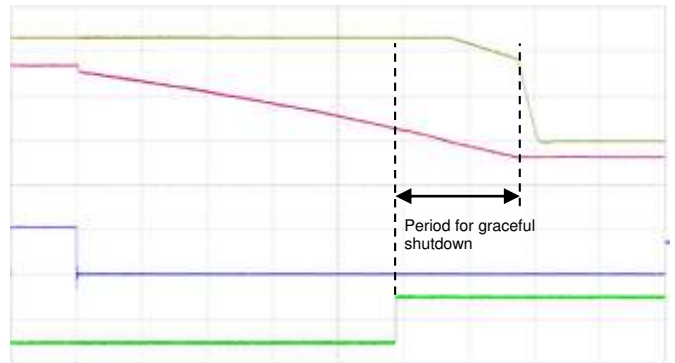

Yellow trace: DC/DC output voltage (5 V/div).
Red trace: hold up voltage (20 V/div).
Blue trace: input voltage (50 V/div).
Green trace: Power Good (5 V/div).
Time scale: (2 ms/div).

Shutdown with Power Good in advance alert mode.

To configure the Power Good to the advance alert mode set `MFR_PG_DEASSERT_TRIP_LEVEL` to a non-zero value. When set to a non-zero value it will define a hold up voltage level at which the Power Good de-asserts. Refer to equation 1 to calculate remaining on-time.

Technical Specification

PIM 4010 series Power Interface Module Input 36-75 V, Output up to 20 A / 780-1080 W	28701-BMR455 40 Rev C November 2017
	© Flex

Thermal Consideration

General

The products are designed to operate in different thermal environments and sufficient cooling must be provided to ensure reliable operation.

For products mounted on a PCB without a heat sink attached, cooling is achieved mainly by conduction, from the pins to the host board, and convection, which is dependent on the airflow across the product. Increased airflow enhances the cooling of the product. The Output Current De-rating graph found in the Output section for each model provides the available output current vs. ambient air temperature and air velocity at $V_i = 53\text{ V}$.

A guardband of 5 °C is applied to the maximum recorded component temperatures when calculating output current de-rating curves.

The product is tested on a 254 x 254 mm, 35 μm (1 oz), 16-layer test board mounted vertically in a wind tunnel with a cross-section of 608 x 203 mm.

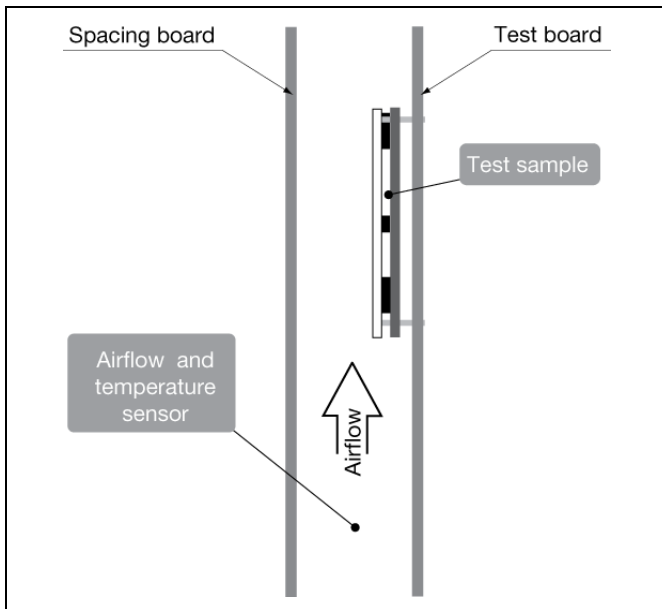

Definition of product operating temperature

The product operating temperature is used to monitor the temperature of the product, and proper thermal conditions can be verified by measuring the temperature at position P1, P2, P3 and P4. The temperature at these positions (T_{P1} , T_{P2} , T_{P3} and T_{P4}) should not exceed the maximum temperature in the table below. Temperature above maximum T_{P1} , T_{P2} , T_{P3} and T_{P4} measured at the reference points P1, P2, P3 and P4 is not allowed and may cause permanent damage. On PIM 4610 position P1 is not populated; use the pad to measure temperature.

Position	Description	Max Temp.
P1	PCB	$T_{P1} = 130\text{ °C}$
P2	Controller	$T_{P2} = 105\text{ °C}$
P3 (Only when $I_{o2} > 3.6\text{A}$)	Buck-IC	$T_{P3} = 130\text{ °C}$
P4*	Transformer	$T_{P4} = 100\text{ °C}$

* The Output Current Derating plots are for functional insulation only. T_{P4} must be monitored if basic insulation is required, a guardband of 10 °C is required according to UL if T_{P4} is monitored with thermocouple.

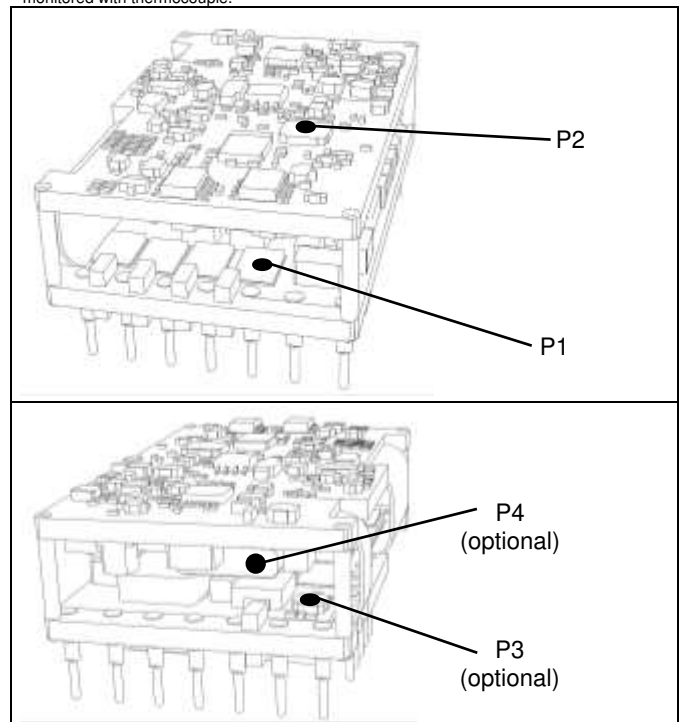

Technical Specification

PIM 4010 series Power Interface Module
 Input 36-75 V, Output up to 20 A / 780-1080 W

28701-BMR455 40 Rev C November 2017

© Flex

Connections

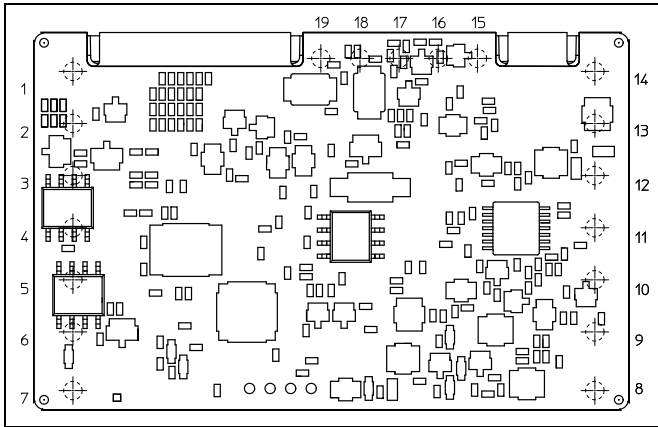

Pin	Designation	Function
1	-IN A	Input A negative feed
2	-IN B	Input B negative feed
3	+IN A	Input A positive feed
4	+IN B	Input B positive feed
5	EN A	Input A enable
6	EN B	Input B enable
7	S GND	Shelf ground
8	+IN 2	External management power supply. May be left open if not needed.
9	+3.3V	Management power, positive output 3.3 V. May be left open if not needed.
10	ADR	I ² C/PMBus address
11	SDA	I ² C/PMBus data
12	SCL	I ² C/PMBus clock
13	GND	Management power, negative output
14	ALARM	Feed loss alarm
15	PG	Power Good
16	-OUT	Main unit, negative output
17	+HU Vadj	Hold up voltage adjust. May be left open if not needed.
18	+OUT	Main unit, positive output
19	+HU	Hold up capacitor bank, positive side. May be left open if not needed.

Technical Specification

PIM 4010 series Power Interface Module
 Input 36-75 V, Output up to 20 A / 780-1080 W

28701-BMR455 40 Rev C November 2017
 © Flex

Mechanical Information

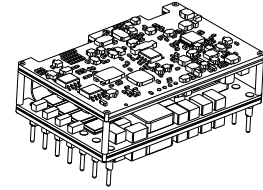
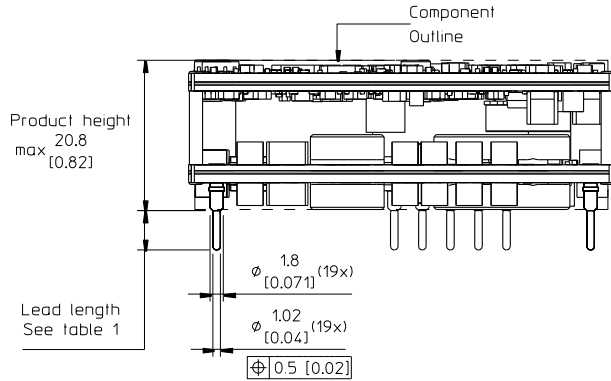

TOP VIEW

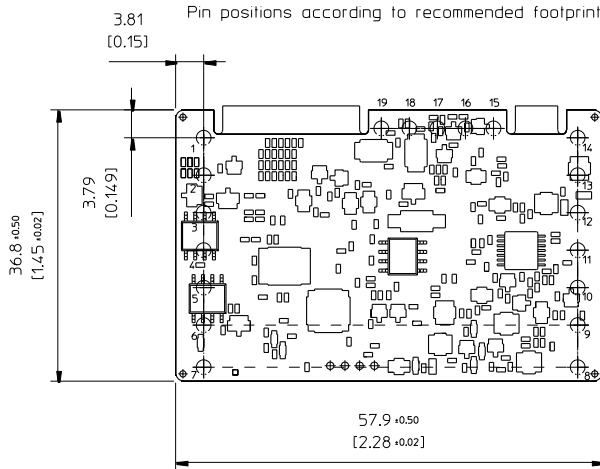

RECOMMENDED FOOTPRINT - TOP VIEW

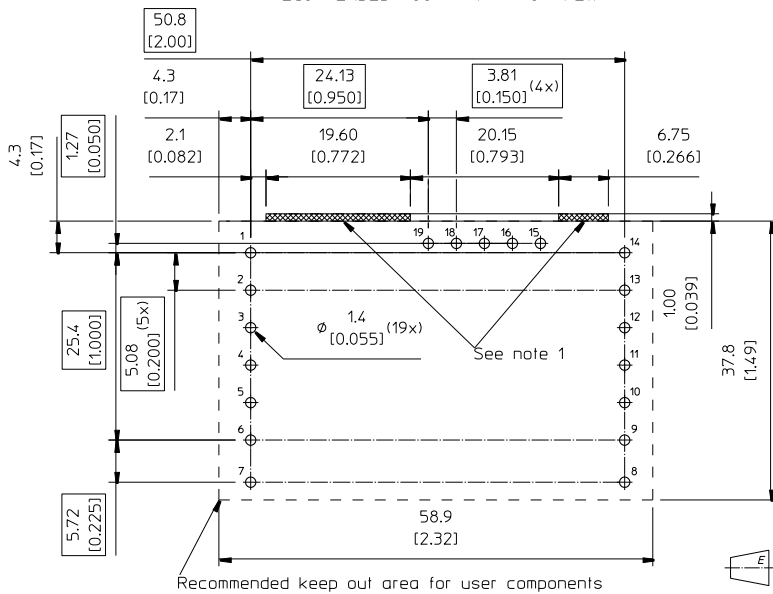
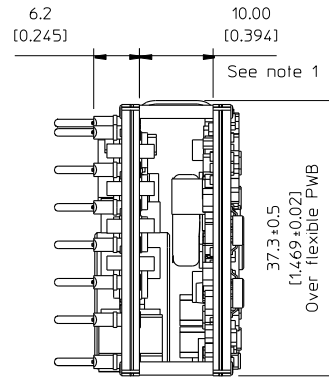

Table 1

Pin option	Lead length
Standard	5.33 [0.21]
LA	3.69 [0.145]
LB	4.57 [0.18]
LC	2.79 [0.11]

Pins:
 Material: Copper alloy
 Plating: Min 0.1 μ m Au over 1-3 μ m Nickel
 Pin position 15 is optional

Notes:
 1-Keep out areas for component in level with flexible PWB height 6.2-16.2 [0.245-0.638]

Weight: Typical 70 g
 All dimensions in mm [inch].
 Tolerances unless specified
 x.x mm \pm 0.50 mm [0.02], x.xx mm \pm 0.25 mm [0.01]
 (not applied on footprint or typical values)

All component placements – whether shown as physical components or symbolical outline – are for reference only and are subject to change throughout the product's life cycle, unless explicitly described and dimensioned in this drawing.

Technical Specification

PIM 4010 series Power Interface Module Input 36-75 V, Output up to 20 A / 780-1080 W	28701-BMR455 40 Rev C November 2017
	© Flex

Soldering Information - Hole Mounting

The hole mounted product is intended for plated through hole mounting by wave or manual soldering. The pin temperature is specified to maximum to 270°C for maximum 10 seconds.

A maximum preheat rate of 4°C/s and maximum preheat temperature of 150°C is suggested. When soldering by hand, care should be taken to avoid direct contact between the hot soldering iron tip and the pins for more than a few seconds in order to prevent overheating.

A no-clean flux is recommended to avoid entrapment of cleaning fluids in cavities inside the product or between the product and the host board. The cleaning residues may affect long time reliability and isolation voltage.

Delivery Package Information

The products are delivered in antistatic trays.

Tray Specifications	
Material	Antistatic PE Foam
Surface resistance	$10^5 < \text{Ohm/square} < 10^{11}$
Bakeability	The trays are not bakeable
Tray thickness	38 mm [1.5 inch]
Box capacity	20 products (1 full tray/box)
Tray weight	63 g empty, 1463 g full tray

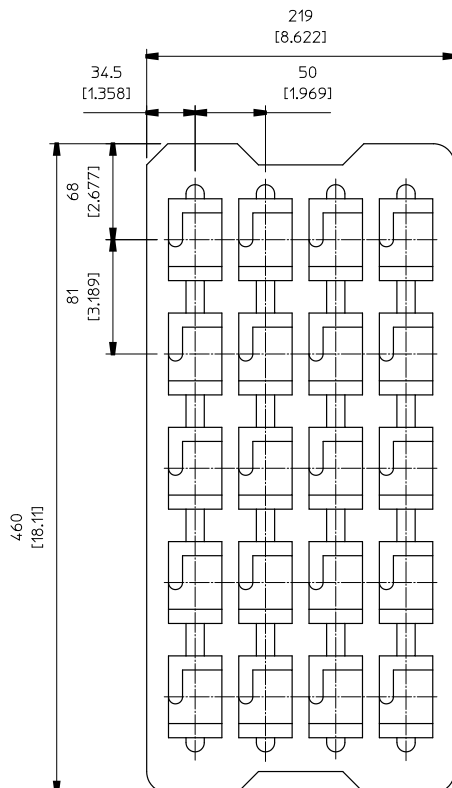

Technical Specification

PIM 4010 series Power Interface Module Input 36-75 V, Output up to 20 A / 780-1080 W	28701-BMR455 40 Rev C November 2017
	© Flex

Product Qualification Specification

Characteristics			
External visual inspection	IPC-A-610		
Change of temperature (Temperature cycling)	IEC 60068-2-14 Na	Temperature range Number of cycles Dwell/transfer time	-40 to 100°C 1000 15 min/0-1 min
Cold (in operation)	IEC 60068-2-1 Ad	Temperature T _A Duration	-45°C 72 h
Damp heat	IEC 60068-2-67 Cy	Temperature Humidity Duration	85°C 85 % RH 1000 hours
Dry heat	IEC 60068-2-2 Bd	Temperature Duration	125°C 1000 h
Electrostatic discharge susceptibility	IEC 61340-3-1, JESD 22-A114 IEC 61340-3-2, JESD 22-A115	Human body model (HBM) Machine Model (MM)	Class 2, 2000 V Class 3, 200 V
Immersion in cleaning solvents	IEC 60068-2-45 XA, method 2	Water Glycol ether Isopropyl alcohol	55°C 35°C 35°C
Mechanical shock	IEC 60068-2-27 Ea	Peak acceleration Duration	100 g 6 ms
Moisture reflow sensitivity ¹	J-STD-020E	Level 1 (SnPb-eutectic) Level 3 (Pb Free)	225°C 260°C
Operational life test	MIL-STD-202G, method 108A	Duration	1000 h
Resistance to soldering heat ²	IEC 60068-2-20 Tb, method 1A	Solder temperature Duration	270°C 10-13 s
Robustness of terminations	IEC 60068-2-21 Test Ua1 IEC 60068-2-21 Test Ue1	Through hole mount products Surface mount products	All leads All leads
Solderability	IEC 60068-2-58 test Td ¹	Preconditioning Temperature, SnPb Eutectic Temperature, Pb-free	150°C dry bake 16 h 215°C 235°C
	IEC 60068-2-20 test Ta ²	Preconditioning Temperature, SnPb Eutectic Temperature, Pb-free	Steam ageing 235°C 245°C
Vibration, broad band random	IEC 60068-2-64 Fh, method 1	Frequency Spectral density Duration	10 to 500 Hz 0.07 g ² /Hz 10 min in each direction

Notes

¹ Only for products intended for reflow soldering (surface mount products)

² Only for products intended for wave soldering (plated through hole products)