

4

3

2

1

THIS DRAWING IS UNPUBLISHED.

RELEASED FOR PUBLICATION

© COPYRIGHT

ALL RIGHTS RESERVED.

LOC DIST

REVISIONS

P	LTR	DESCRIPTION	DATE	DWN	APVD
	C2	ECR-13-009280	06JUN2013	XZ	LZ

REPLACED BY OCEAN STYLE APPLICATOR PART NUMBER 2151451-1

FOR REPLACEMENT PARTS FOR APPLICATOR 680826 REFER TO ADDITIONAL PAGE(S). SPARE PARTS KIT (IF LISTED) WILL REMAIN AVAILABLE.

THE REPLACEMENT OCEAN STYLE APPLICATOR HAS THE SAME TERMINATOR/PRESS INTERFACE AS APPLICATOR 680826

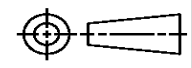
THIS DRAWING IS A CONTROLLED DOCUMENT.		DWN X. ZHAO	 TE Connectivity		
DIMENSIONS:		CHK L. ZHANG			
		APVD L. ZHANG	NAME		
TOLERANCES UNLESS OTHERWISE SPECIFIED:		PRODUCT SPEC	SIDE FEED HDM APPLICATOR		
0 PLC ± 1 PLC ± 2 PLC ± 3 PLC ± 4 PLC ± ANGLES ±		APPLICATION SPEC	SIZE	CAGE CODE	DRAWING NO
MATERIAL		WEIGHT	A3		©- 680826
FINISH		SCALE		SHEET 1 OF 2	REV C2

Dimensioning and tolerancing per ASME Y14.5M-2009

Dimensioning and tolerancing per ASME Y14.5M-2009

A

B

C

D

B

C

D

Dimensioning and tolerancing per ASME Y14.5M-2009

DRAWING MADE IN THIRD ANGLE PROJECTION

680826 680826

/home/us012285/dmtecom

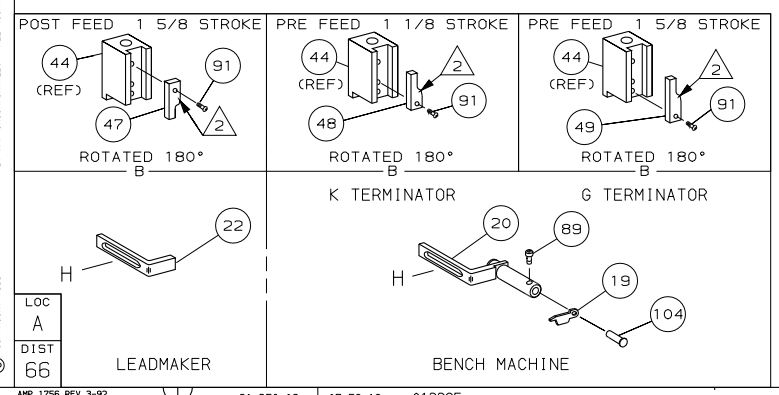
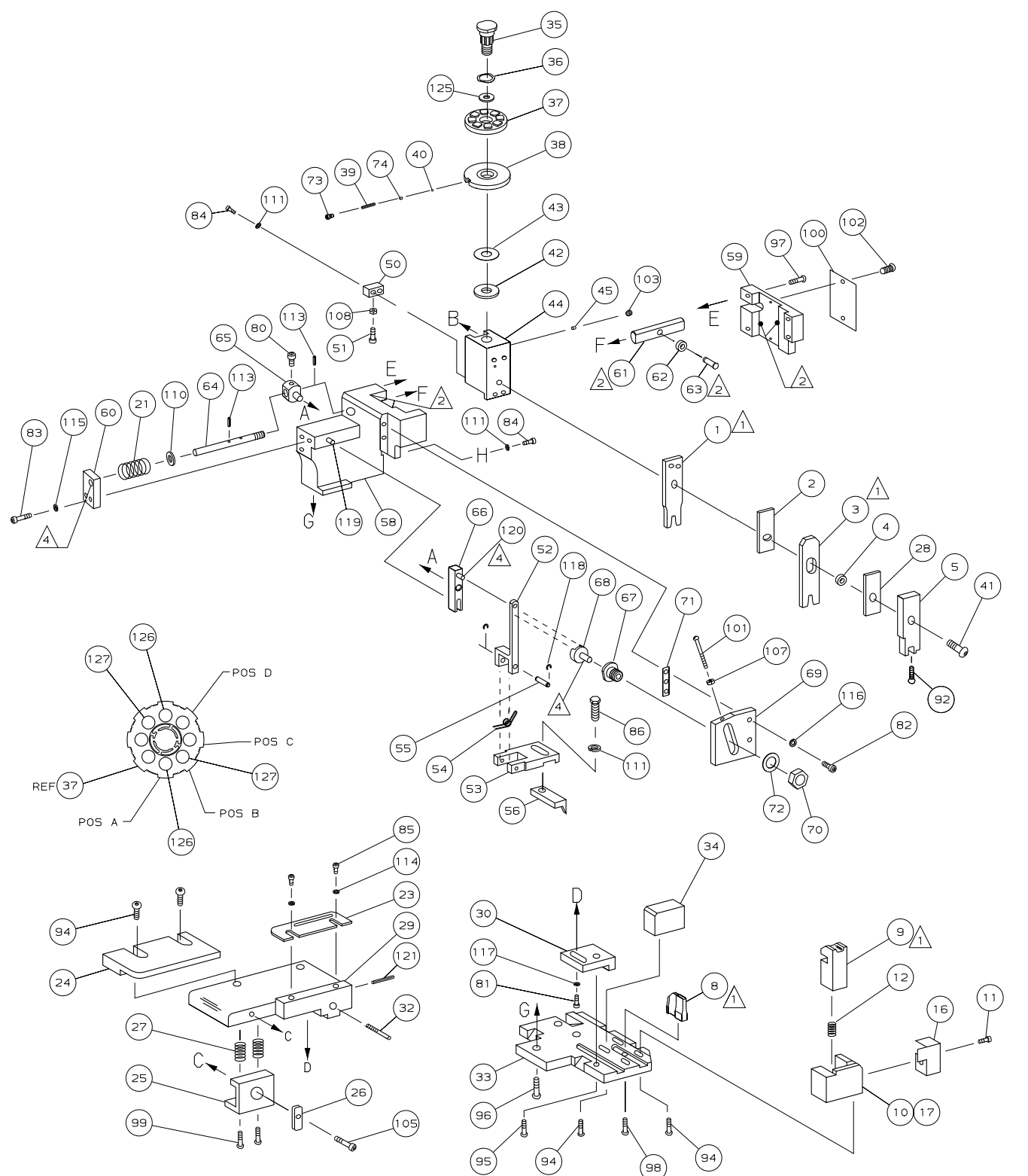
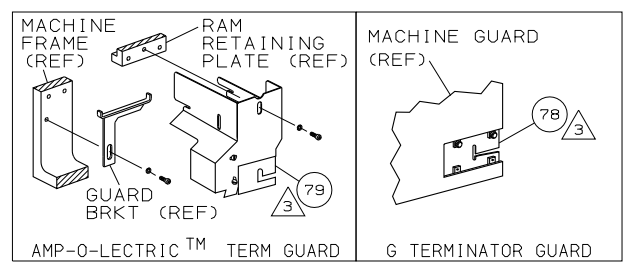

P	F	L	R
REVISION	RECORD	APP	DATE
SEE SHEET 1			

QTY REQD PER ASSY	DWG SIZE	PART NO	DESCRIPTION	ITEM NO
		REVISION OF EACH ASSY NO (WHEN BLANK, USE DWG REVISION)		
PARTS LIST				
MATL		HT TR		FIN
DR	20DEC06	APP	21DEC06	
CHK	21DEC06	REL	T. BENCHOFF	
NAME		SIDE FEED HDM APPLICATOR		MACHINE REF
SCALE		D		MINI APPL
DWG NO		680826		SHEET
CAGE CODE		00779		2 of 2
CUSTOMER AND ASSEMBLY DRAWING				REV
				C1
				RESTRICTED TO

16SEP1999
 RELEASED FOR PUBLICATION
 BY AMP INCORPORATED. ALL RIGHTS RESERVED.
 THIS DRAWING IS UNCONTROLLED.
 © COPYRIGHT 1999
 AMP 1756 REV 3-92