

Development Board EPC9083 Quick Start Guide

EPC2207

60 W Class-E Wireless Power Amplifier

Revision 2.0

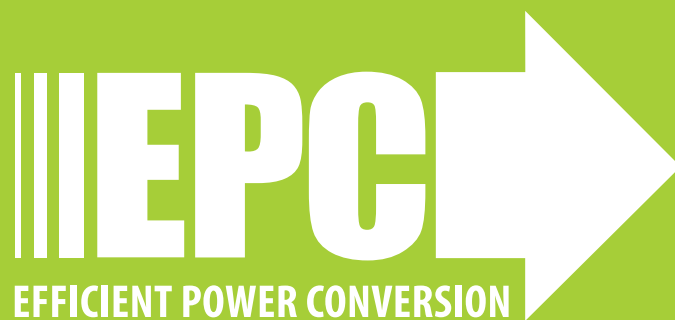

DESCRIPTION

The EPC9083 is a high efficiency, differential mode Class-E amplifier development board that can operate up to 15 MHz, including 6.78 MHz which is popular for wireless power. However, this board is not pre-configured for any particular frequency. Higher frequency may be possible but is currently under evaluation. The purpose of this development board is to simplify the evaluation process of class-E amplifier technology using eGaN® FETs by allowing engineers to easily mount all the critical class-E components on a single board that can be easily connected into an existing system.

This board may also be used for applications where a low side switch is utilized. Examples include, and are not limited to, push-pull converters, current-mode Class D amplifiers, common source bi-directional switch, and generic high voltage narrow pulse width applications such as LiDAR.

The amplifier board features the 200 V rated EPC2207 eGaN FET. The amplifier is set to operate in differential mode and can be re-configured to operate in single-ended mode and includes the gate driver and logic supply regulator.

For more information on the EPC2207 eGaN FETs please refer to the datasheet available from EPC at www.epc-co.com. The datasheet should be read in conjunction with this quick start guide.

DETAILED DESCRIPTION

The Amplifier Board (EPC9083)

Figure 1 shows the schematic of a single-ended, Class-E amplifier with ideal operation waveforms where the amplifier is connected to a tuned load such as a highly resonant wireless power coil. The amplifier has not been configure due to the specific design requirements such as load resistance and operating frequency. The design equations of the specific Class-E amplifier support components are given in this guide and specific values suitable for a RF amplifier application can then be calculated.

Figure 2 shows the differential mode Class-E amplifier EPC9083 demo board power circuit schematic. In this mode the output is connected between Out 1 and Out 2. A block-wave external oscillator with 50 % duty cycle and 0 V – 5 V signal amplitude is used as a signal for the board. Duty cycle modulation is recommended only for advanced users who are familiar with the Class-E amplifier operation and require additional efficiency.

The EPC9083 is also provided with a 5 V regulator to supply power to the logic circuitis and gate driver. Adding a 0 Ω resistor in position R90 allows the EPC9083 to be powered using a single-supply voltage; however in this configuration the maximum operating voltage is limited to between 7 V and 12 V.

Single-ended Mode operation

Although the default configuration is differential mode, the demo board can be re-configured for single-ended operation by shorting out C74 (which disables only the drive circuit) and connecting the load between Out 1 and GND only (see figures 2 and 5 for details).

Class-E amplifier operating limitations

The impact of load resistance variation is significant to the performance of the Class-E amplifier, and must be carefully analyzed to select the optimal design resistance.

Table 1: Performance Summary (TA = 25°C) EPC9083

Symbol	Parameter	Conditions	Min	Max	Units
V _{IN}	Main Supply Voltage Range	Class-E Configuration	0	40	V
		Current Mode Class-D Configuration	0	35	V
		Push-Pull Configuration	0	80	V
V _{DD}	Control Supply Input Range		7	12	V
I _{OUT}	Switch Node Output Current (each)			4*	A
V _{OSC}	Oscillator Input Threshold	Input 'Low'	-0.3	1.5	V
		Input 'High'	3.5	5	V

*Maximum current depends on die temperature – actual maximum current will be subject to switching frequency, bus voltage and thermals.

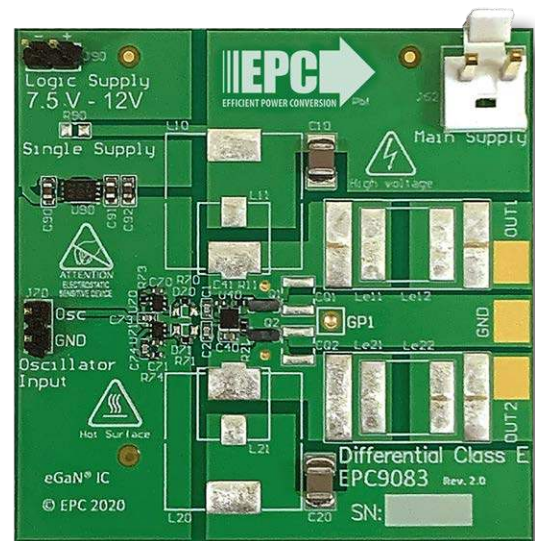

EPC9083 Amplifier Board

The impact of load resistance (R_{Load} – Real part of Z_{Load}) variation on the operation of the Class-E amplifier is shown in figure 3. When operating a Class-E amplifier with a load resistance (R_{Load} – Real part of Z_{Load}) that is below the design value (see the waveform on the left of figure 3), the load tends to draw current from the amplifier too quickly. To compensate for this condition, the amplifier supply voltage is increased to yield the required output power. The shorter duration of the energy charge cycle leads to a significant increase in the voltage to which the switching device is exposed. This is done in order to capture sufficient energy and results in device body diode conduction during the remainder of the device off period. This period is characterized by a linear increase in device losses as a function of decreasing load resistance (R_{Load}).

When operating the Class-E amplifier with a load resistance (R_{Load}) that is above the design value (see the waveform on the right of figure 3), the load tends to draw insufficient current from the amplifier, resulting in an incomplete voltage transition. When the device switches there is a residual voltage across the device, which leads to shunt capacitance ($C_{OSS} + C_{sh}$) losses. This period in the cycle is characterized by an exponential increase in device losses as function of increasing reflected load resistance.

Given these two extremes of the operating load resistance (R_{Load}), the optimal point between them must be determined. In this case, the optimal point yields the same device losses for each of the extreme load resistance points and is shown in the lower center graph of figure 3. This optimal design point can be found through trial and error, or using circuit simulation.

Class-E amplifier design

For this amplifier only three components need to be specifically designed; 1) the extra inductor (L_e), 2) the shunt capacitor (C_{sh}) and, 3) the selection of a suitable switching device. The RF choke (L_{RFck}) value is less critical and hence can be chosen or designed.

The design equations for the Class-E amplifier have been derived by N. Sokal [1]. To simplify these equations, the value of Q_L in [1] is set to infinity, which is a reasonable approximation in most applications within the frequency capability of this development board. The design needs to have a specific load resistance (R_{Load}) value and desired load power (P_{Load}) that is used to begin the design, which then drives the values of the other components, including the magnitude of the supply voltage.

The Class-E amplifier passive component design starts with the load impedance value (Z_{Load}) shown in figure 1. The reactive component of Z_{Load} is tuned out using a series capacitor C_s , which also serves as a DC block, resulting in R_{Load} . It is a common mistake to ignore the need for the DC block, where a failure to do so can yield a DC current from the supply through to the load, and lead to additional losses in several components in that path.

First, using the equations in figure 4, both the extra inductor L_e (equation 2) and shunt capacitor (equation 3) values can be determined [2], [3]. The value of the shunt capacitor includes the C_{OSS} of the switching device, which must be subtracted from the calculated value to yield the actual external capacitor (C_{sh}) value. To do this, first the magnitude of the supply voltage (V_{DD}) is calculated using equation 1, which in turn can be used to determine the peak device voltage ($3.56 \cdot V_{DD}$).

The RMS value of the peak device voltage is then used to determine the C_{OSSQ} of the device at that voltage. This is the capacitance that will be deducted from the calculated shunt capacitor to reveal the external shunt capacitor (C_{sh}) value. The C_{OSSQ} of the device can be calculated by integrating the C_{OSS} as function of voltage using equation 4. If the C_{OSSQ} value is larger than the calculated shunt capacitance, the design cannot be realized for the load resistance specified and a new load resistance (R_{Load}) must be chosen.

Finally, the choke (L_{RFck}) can be designed using equation 5 and, in this case, a minimum value is specified. Larger values yield lower ripple current, which can lead to a more stable operating amplifier. A too-low value will lead to increased operating losses and change the mode of operation of the amplifier. In some cases this can be intentional.

Here:

R_{Load} = Load Resistance [Ω]

P_{Load} = Load Power [W]

V_{DD} = Amplifier Supply Voltage [V]

f = Operating Frequency [Hz]

L_e = Extra Inductor [H]

C_{sh} = Shunt Capacitor [F]

C_{OSS} = Output Capacitance of the FET [F]

C_{OSSQ} = Charge Equivalent Device Output Capacitance [F]
(See figure 6 of the [EPC2207 datasheet](#))

V_{DS} = Drain-Source Voltage of the FET [V]

L_{RFck} = RF Choke Inductor [H]

C_s = Series Tuning Capacitor [F]

Z_{Load} = Load Impedance [Ω]

NOTE: For differential mode amplifier design details, please refer to the application note [AN021: eGaN FETs for Low Cost Resonant Wireless Power Applications](#)

[1] N.O. Sokal, "Class-E RF Power Amplifiers," QEX, Issue 204, pp. 9–20, January/ February 2001.

[2] M. Kazimierczuk, "Collector amplitude modulation of the Class-E tuned power amplifier," IEEE Transactions on Circuits and Systems, June 1984, Vol.31, No. 6, pp. 543–549.

[3] Z. Xu, H. Lv, Y. Zhang, Y. Zhang, "Analysis and Design of Class-E Power Amplifier employing SiC MESFETs," IEEE International Conference on Electron Devices and Solid-State Circuits (EDSSC) 2009, 25–27 December 2009, pp 28–31.

QUICK START PROCEDURE

The EPC9083 amplifier board is easy to set up to evaluate the performance of the eGaN FET in a class-E amplifier application. Once the design of the passive components has been completed and installed, then the board can be powered up and tested.

1. Make sure the entire system is fully assembled prior to making electrical connections including an applicable load.
2. With power **off**, connect the **main** input power supply bus to J62 as shown in figure 5. Note the polarity of the supply connector. Set the voltage to 0 V.
3. With power **off**, connect the **logic** input power supply bus to J90 as shown in figure 5. Note the polarity of the supply connector. Set the voltage to between 7 V and 12 V.
4. Make sure all instrumentation is connected to the system. This includes the external oscillator to control the circuit.
5. Turn on the logic supply voltage.
6. Turn on the main supply voltage and increase to the desired value. Note operating conditions and in particular the thermal performance and voltage of the FETs to prevent over-temperature and over-voltage failure.
7. Once operation has been confirmed, observe the device voltage, efficiency and other parameters on both the amplifier and device boards.
8. For shutdown, please follow steps in the reverse order.

NOTE: When measuring the high frequency content switch-node, care must be taken to avoid long ground leads. An oscilloscope probe connection (preferred method) has been built into the board to simplify the measurement of the Drain-Source Voltage (shown in figure 6). The choice of oscilloscope probe needs to consider tip capacitance where this will appear in parallel with the shunt capacitance thereby altering the operating point of the amplifier.

Pre-Cautions

The EPC9083 development board showcases the EPC2207 eGaN FETs in a class-E amplifier application. Although the electrical performance surpasses that of traditional silicon devices, their relatively smaller size does require attention paid to thermal management techniques.

The EPC9083 development board has no current or thermal protection and care must be exercised not to over-current or over-temperature the devices. Excessively wide load impedance range variations can lead to increased losses in the devices. The operator must observe the temperature of the gate driver and eGaN FETs to ensure that both are operating within the thermal limits as per the datasheets. Always check operating conditions and monitor the temperature of the EPC devices using an IR camera.

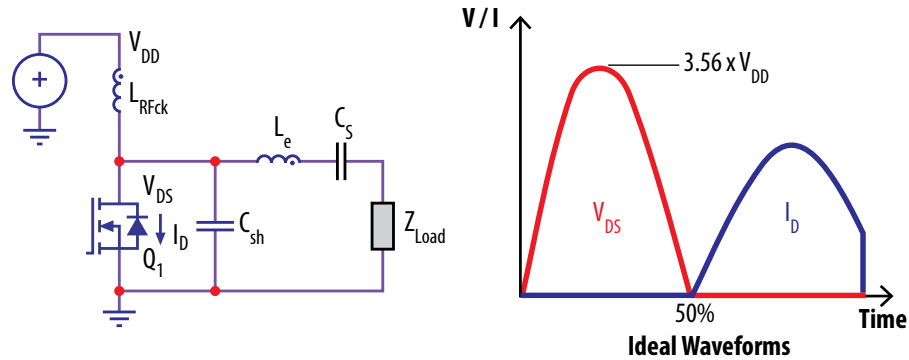

Figure 1: Single-ended, Class-E amplifier with ideal operation waveforms

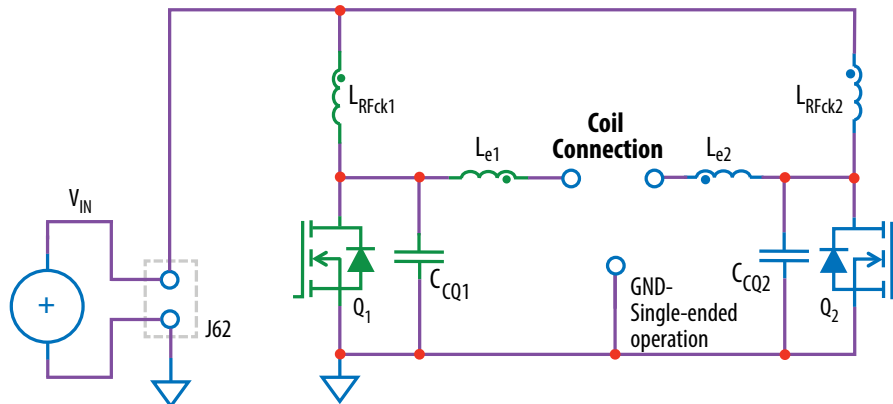

Figure 2: EPC9083 power circuit schematic

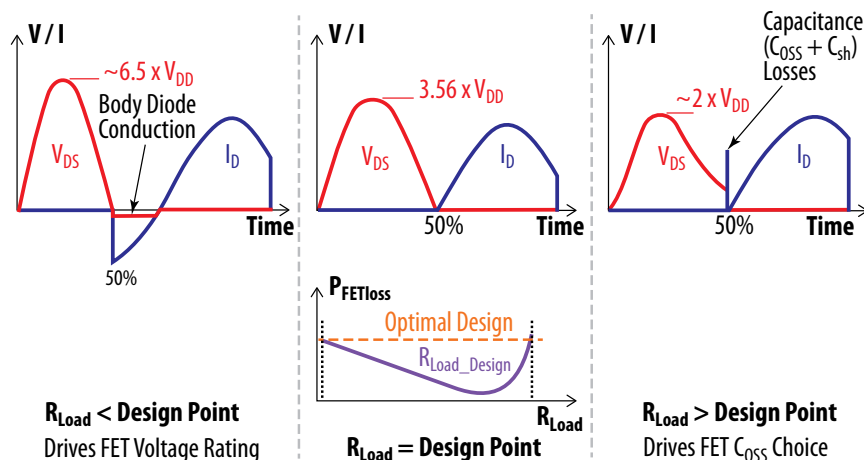

Figure 3: Class-E operation under various load conditions that can be used to determine the optimal design load resistance (R_{Load})

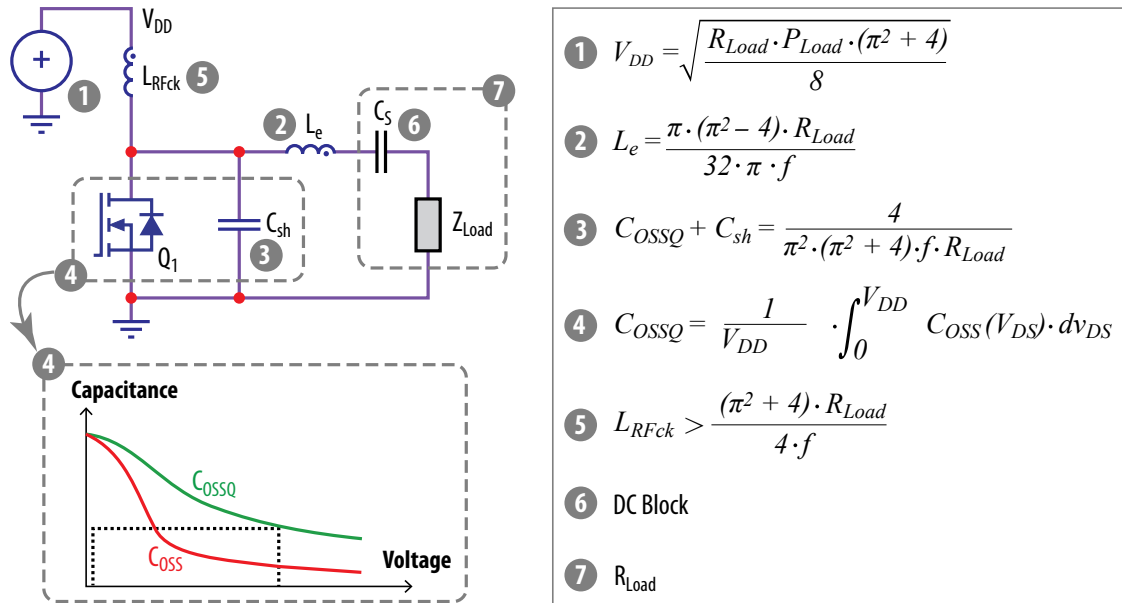

Figure 4: Class-E amplifier design process with equations

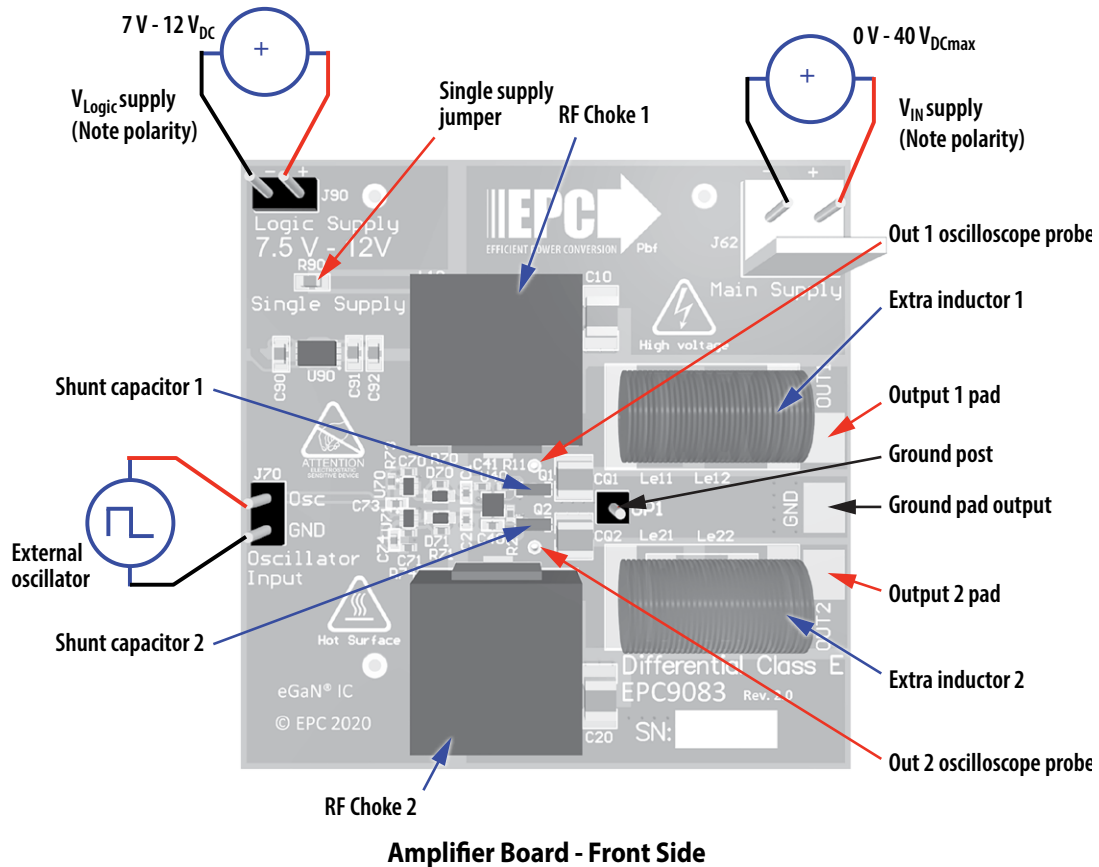

Figure 5: Proper connection and measurement setup for the amplifier board

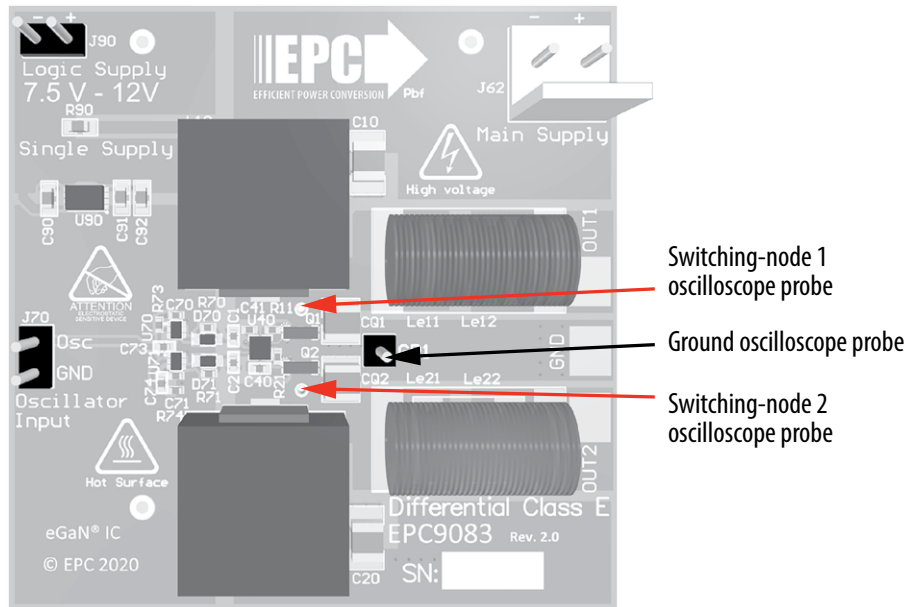

Figure 6: Proper measurement of the drain voltage

Table 2: Bill of Materials - Amplifier Board

Item	Qty	Reference	Part Description	Manufacturer	Part #
1	2	C10, C20	Capacitor, 2.2 μ F \pm 10% 100 V X7R	Taiyo Yuden	HMK325B7225KN-T
2	3	C90, C91, C92	Capacitor, 1 μ F 25 V X7R 0603	Würth	885012206076
3	4	C1, C2, C73, C74	Capacitor, 22 pF 50 V COG/NP0	Würth	885012005057
4	1	C40	Capacitor, 4.7 μ F 10 V X5R	Samsung	CL05A475MP5NRNC
5	3	C41, C70, C71	Capacitor, 0.1 μ F 16 V X7R	Würth	885012205037
6	1	J62	Connector, .156" Male Vert.	Molex	26614020
7	2	J70, J90	Connector, .1" Male Vert.	Würth	61300211121
8	2	Q1, Q2	eGaN FET, 200 V, 14 A, 22 m Ω	EPC	EPC2207
9	2	R70, R71	Resistor, 0 Ω JUMPER, 1/16 W 0402	Samsung	RC1005J000CS
10	2	R11, R21	Resistor, 2.2 Ω \pm 5% 0.063 W, 1/16 W, 0402	Yageo	RC0402JR-072R2L
11	1	R73	Resistor, 10 k Ω 1% 1/16W 0402	Yageo	RC0402FR-0710KL
12	1	R74	Resistor, 10 k Ω 5% 1/10 W 0402	Panasonic	ERJ-2GEJ103
13	1	U90	IC, Linear Voltage Regulator, 5 V 250 mA DFN	Microchip	MCP1703T-5002E/MC
14	1	U40	IC GATE DRVR HALF-BRIDGE 12DSBGA	Texas Instruments	LMG1205YFXR
15	1	U70	IC GATE NAND 1CH 2-INP 6MICROPAK	Fairchild	NC7SZ00L6X
16	1	U71	IC GATE AND 1CH 2-INP 6MICROPAK	Fairchild	NC7SZ08L6X
18	1	GP1	Connector Header Throughhole 1 position	Würth	61300111121

Table 3: Optional Components

Item	Qty	Reference	Part Description
1	2	D70, D71	Schottky Diode, 40 V 30 mA
2	2	L10, L20	Inductor, 0805
3	2	L11, L21	FIXED IND 10 μ H 3.5 A 33 m Ω SMD
4	2	Le11, Le21	Inductor
5	2	Le12, Le22	Inductor
6	2	PH1, PH2	Probe Hole
7	1	R90	Resistor, 0603
8	2	CQ1, CQ2	Capacitor, 180 pF 1000 V COG 5% HI FREQ

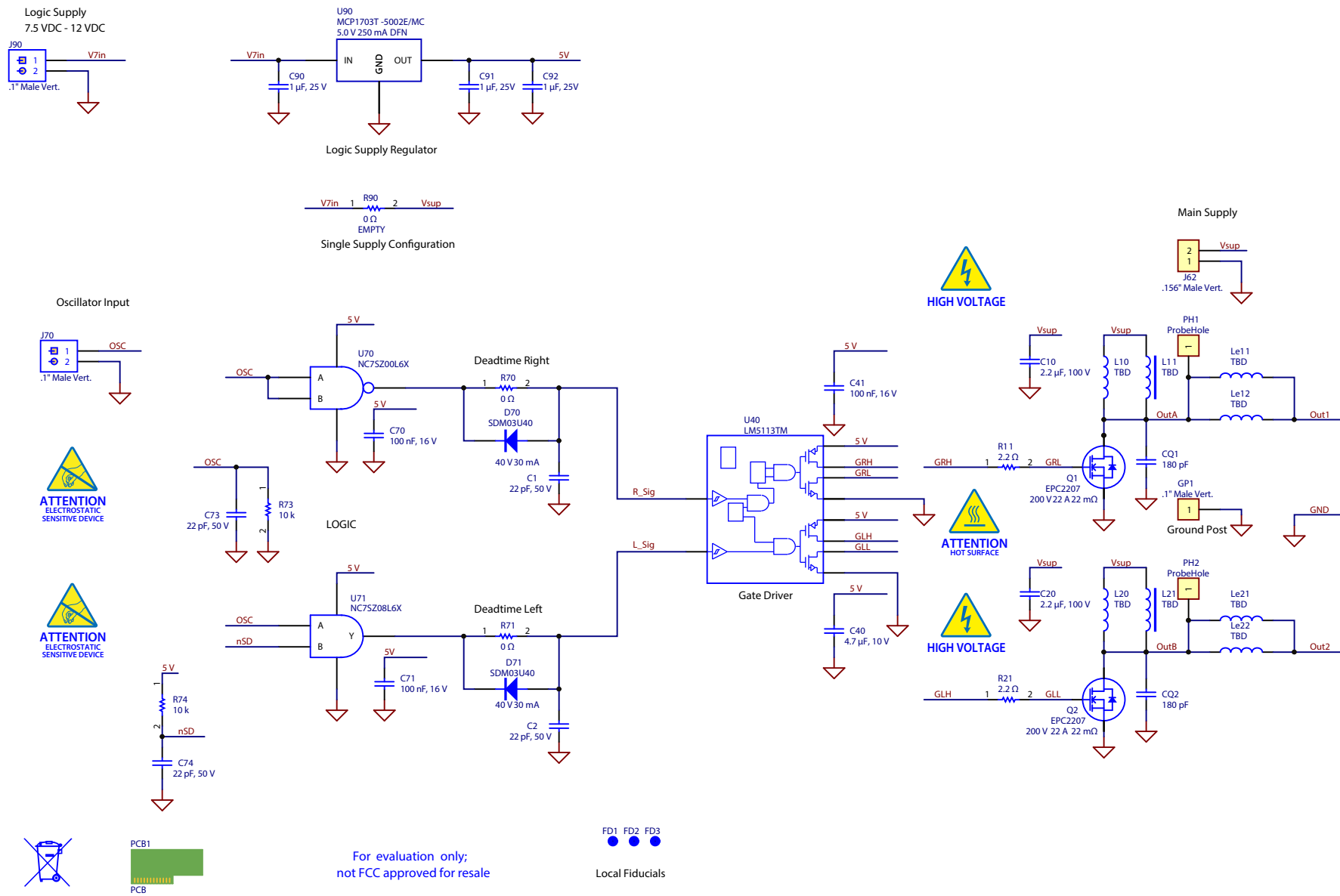

Figure 7: EPC9083 Class-E amplifier schematic.

For More Information:

Please contact info@epc-co.com
or your local sales representative

Visit our website:

www.epc-co.com

Sign-up to receive
EPC updates at
bit.ly/EPCupdates
or text "EPC" to 22828



EPC Products are distributed through Digi-Key.

www.digikey.com

Demonstration Board Warning and Disclaimer

The EPC9083 board is intended for product evaluation purposes only and is not intended for commercial use. Replace components on the Evaluation Board only with those parts shown on the parts list (or Bill of Materials) in the Quick Start Guide. Contact an authorized EPC representative with any questions.

This board is intended to be used by certified professionals, in a lab environment, following proper safety procedures. Use at your own risk.

As an evaluation tool, this board is not designed for compliance with the European Union directive on electromagnetic compatibility or any other such directives or regulations. As board builds are at times subject to product availability, it is possible that boards may contain components or assembly materials that are not RoHS compliant. Efficient Power Conversion Corporation (EPC) makes no guarantee that the purchased board is 100% RoHS compliant.

The Evaluation board (or kit) is for demonstration purposes only and neither the Board nor this Quick Start Guide constitute a sales contract or create any kind of warranty, whether express or implied, as to the applications or products involved.

Disclaimer: EPC reserves the right at any time, without notice, to make changes to any products described herein to improve reliability, function, or design. EPC does not assume any liability arising out of the application or use of any product or circuit described herein; neither does it convey any license under its patent rights, or other intellectual property whatsoever, nor the rights of others.