

DO NOT SCALE FROM THIS PRINT

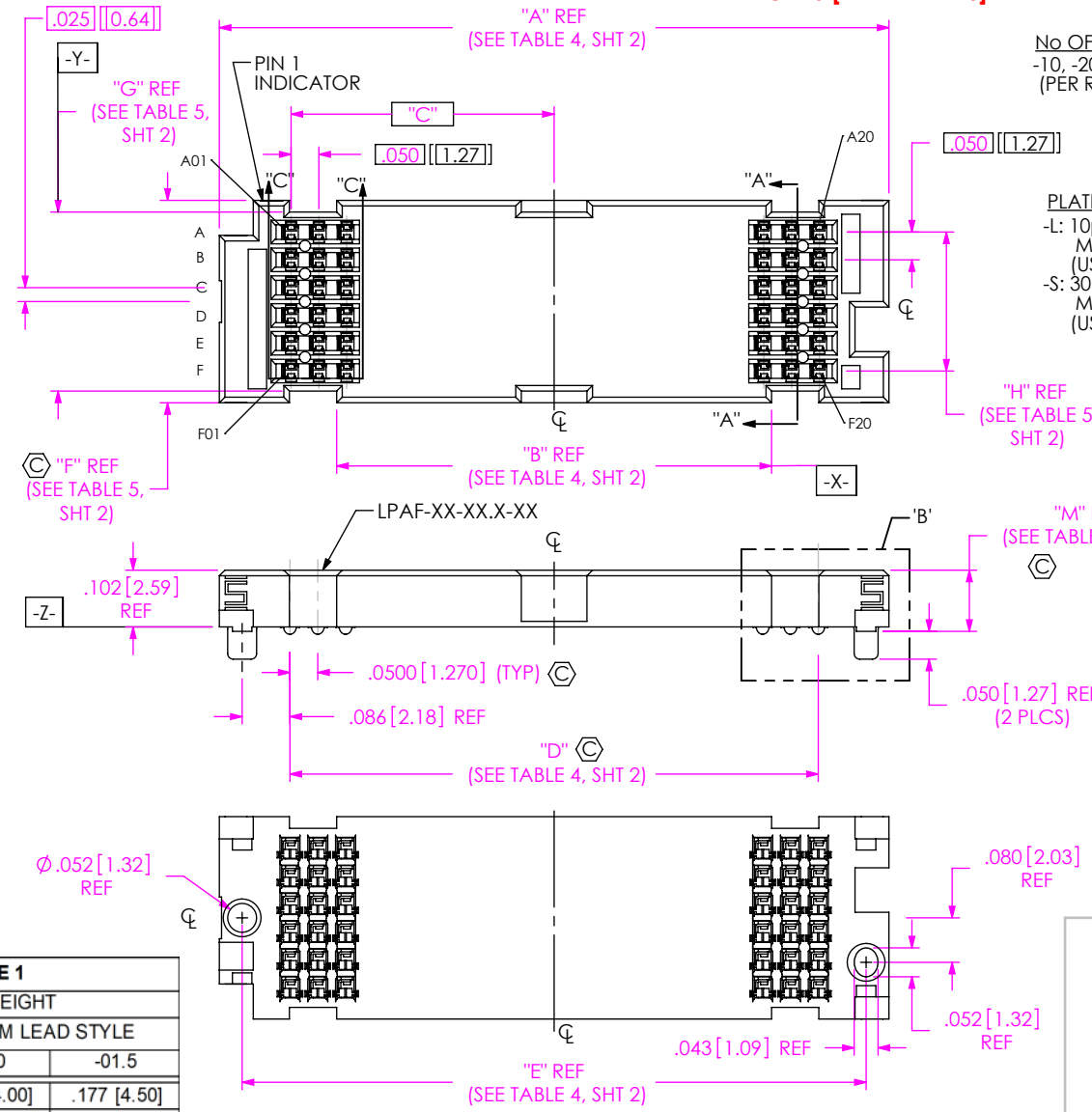

No OF POSITIONS
-10, -20, -30, -40, **-50 (PER ROW)

LEAD STYLE
-03.0: 3.0mm
-03.5: 3.5mm

PLATING SPECIFICATION
-L: 10µ" GOLD ON CONTACT AREA, MATTE TIN ON TAIL (USE SUB-C-289-XX.X-L-X)
-S: 30µ" GOLD ON CONTACT AREA, MATTE TIN ON TAIL (USE SUB-C-289-XX.X-S-X)

ROW SPECIFICATION
-04: 4 ROW
-06: 6 ROW
-08: 8 ROW
*-10: 10 ROW

TAPE & REEL (SEE NOTES 7 & 9)
-TR: TAPE & REEL
-FR: FULL REEL QTY TAPE & REEL

OPTION
-K: POLYIMIDE PAD (SEE FIG 3, SHT 3)

SOLDER COMPOSITION & STYLE
-1: 63.0% TIN / 37.0% LEAD CRIMP TAIL (USE SUB-C-289-XX.X-X-1)
-2: 95.5% TIN / 3.8% SILVER .7% COPPER CRIMP TAIL (USE SUB-C-289-XX.X-X-2)

(* = NOT TOOLED)
(** = NOT TOOLED FOR 04, 06 & 10 ROWS)

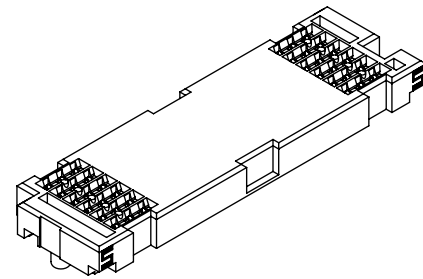

LPAF ASSEMBLY	"BODY CALLOUT"	"CONTACT SUB ASSEMBLY"
LPAF-XX-03.0-X-XX-X-K-TR	LPAF-XX-03.0-XX	SUB-C-289-03.0-X-X
LPAF-XX-03.5-X-XX-X-K-TR	LPAF-XX-03.5-XX	SUB-C-289-03.5-X-X

LPAF LEAD STYLE	LPAM LEAD STYLE	
	-01.0	-01.5
-03.0	.157 [4.00]	.177 [4.50]
-03.5	.177 [4.50]	.197 [5.00]

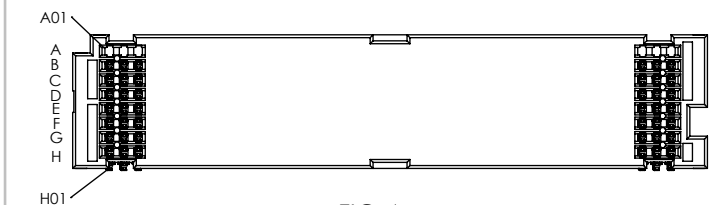

FIG 4
LPAF-40-03.0-X-08-X-XR SHOWN (DIFFERENT AS SHOWN, OTHERWISE SAME AS FIG 1)

FIG 1
LPAF-20-03.0-X-06-X-K-XR SHOWN (SOME FEATURES REMOVED FOR CLARITY)

NOTES:

1. Ⓞ REPRESENTS A CRITICAL DIMENSION.
2. PUSH OUT FORCE 0.25LBS [1.11N].
3. THIS DIMENSION IS TO BE CHECKED AT FOUR CORNERS" PIN A1, AX, N1, & NX, WHERE X IS THE NUMBER OF POSITIONS AND N IS THE NUMBER OF ROWS.
4. NOTE DELETED.
5. NOTE DELETED.
6. NOTE DELETED.
7. ATTACH LABEL -4X2 TO EACH REEL.
8. MAXIMUM VARIATION BETWEEN ROWS: 0.003 [0.08]. TO BE MEASURED AT FIRST AND LAST POSITIONS ONLY, ALL ROWS.
9. ORDERS WILL BE PACKAGED ACCORDING TO THE SAMTEC PACKAGING EFFICIENCY STANDARDS (SPES) FOUND ON WWW.SAMTEC.COM.

UNLESS OTHERWISE SPECIFIED, DIMENSIONS ARE IN INCHES[MILLIMETERS].
TOLERANCES ARE:
DECIMALS ANGLES
.XX: ±.01 [.3] 2°
.XXX: ±.005 [.13]
.XXXX: ±.0020 [.051]

PROPRIETARY NOTE
THIS DOCUMENT CONTAINS CONFIDENTIAL AND PROPRIETARY INFORMATION AND ALL DESIGN, MANUFACTURING, REPRODUCTION, USE, PATENT RIGHTS AND SALES RIGHTS ARE EXPRESSLY RESERVED BY SAMTEC, INC. THIS DOCUMENT SHALL NOT BE DISCLOSED, IN WHOLE OR PART, TO ANY UNAUTHORIZED PERSON OR ENTITY NOR REPRODUCED, TRANSFERRED OR INCORPORATED IN ANY OTHER PROJECT IN ANY MANNER WITHOUT THE EXPRESS WRITTEN CONSENT OF SAMTEC, INC.



520 PARK EAST BLVD., NEW ALBANY, IN 47150
PHONE: 812-944-6733 FAX: 812-948-5047
e-Mail info@SAMTEC.com code 55322

MATERIAL: DO NOT SCALE DRAWING SHEET SCALE: 3:1
INSULATOR: LCP, COLOR: BLACK
CONTACT: COPPER ALLOY

DESCRIPTION: LPAF SOCKET ASSEMBLY
DWG. NO. LPAF-XX-XX.X-X-XX-X-K-XR

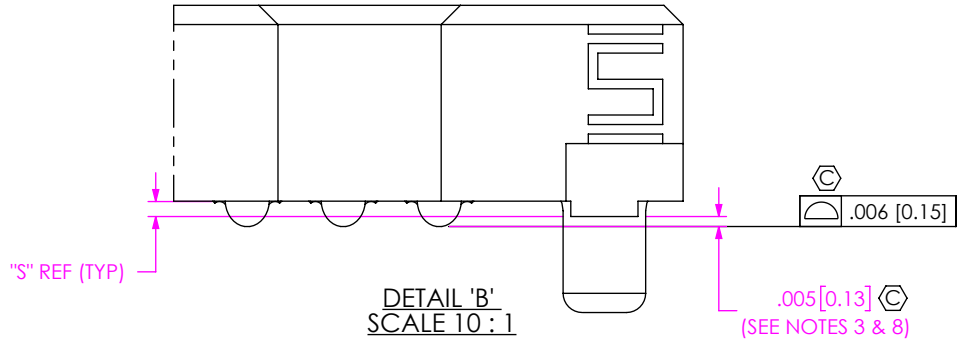
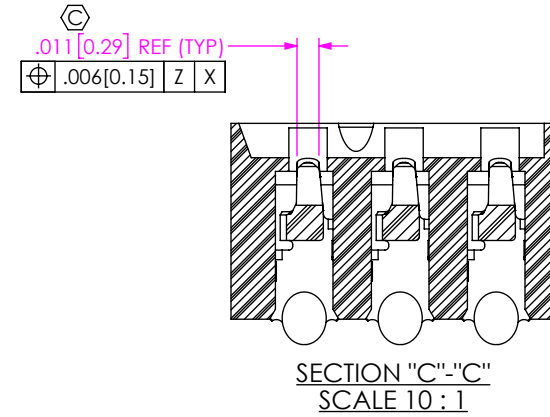
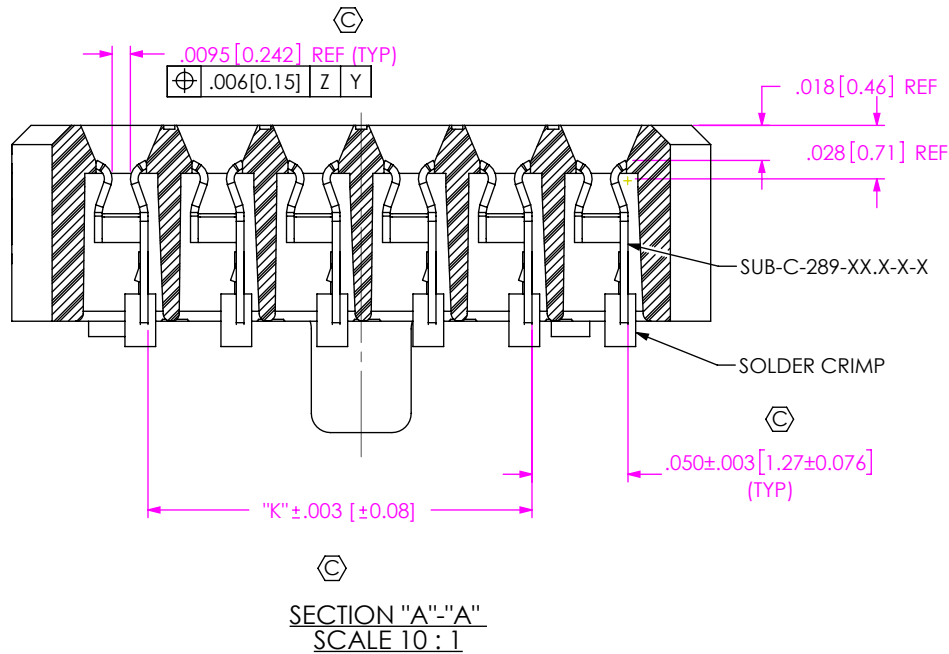

TABLE 3

POS	LEAD STYLE	"M"	"S"
-10 THRU -30	-03.0	0.110 [2.79]	0.008 [0.20]
-40, -50		0.110 [2.79]	0.008 [0.20]
-10 THRU -30	-03.5	0.130 [3.30]	0.018 [0.46]
-40, -50		0.130 [3.30]	0.018 [0.46]

TABLE 4

No. OF POS	"A"	"B"	"C"	"D"	"E"
-10	.704 [17.88]	.282 [7.16]	.223 [5.66]	.4500 [11.430]	.622 [15.80]
-20	1.204 [30.58]	.782 [19.86]	.473 [12.01]	.9500 [24.130]	1.122 [28.50]
-30	1.704 [43.28]	1.282 [32.56]	.723 [18.36]	1.4500 [36.830]	1.622 [41.20]
-40	2.204 [55.98]	1.782 [45.26]	.973 [24.71]	1.9500 [49.530]	2.122 [53.90]
-50	2.704 [68.68]	2.282 [57.96]	1.223 [31.06]	2.4500 [62.230]	2.622 [66.60]

TABLE 5

ROWS	"F"	"G"	"H"	"K"
-04	.264 [6.71]	.222 [5.64]	.1500 [3.810]	.150 [3.81]
-06	.364 [9.25]	.322 [8.18]	.2500 [6.350]	.250 [6.35]
-08	.464 [11.79]	.422 [10.72]	.3500 [8.890]	.350 [8.89]
-10	.564 [14.33]	.522 [13.26]	.4500 [11.430]	.450 [11.43]

<p>PROPRIETARY NOTE</p> <p>THIS DOCUMENT CONTAINS CONFIDENTIAL AND PROPRIETARY INFORMATION AND ALL DESIGN, MANUFACTURING, REPRODUCTION, USE, PATENT RIGHTS AND SALES RIGHTS ARE EXPRESSLY RESERVED BY SAMTEC, INC. THIS DOCUMENT SHALL NOT BE DISCLOSED, IN WHOLE OR PART, TO ANY UNAUTHORIZED PERSON OR ENTITY NOR REPRODUCED, TRANSFERRED OR INCORPORATED IN ANY OTHER PROJECT IN ANY MANNER WITHOUT THE EXPRESS WRITTEN CONSENT OF SAMTEC, INC.</p>	<p>samtec</p> <p>520 PARK EAST BLVD, NEW ALBANY, IN 47150 PHONE: 812-944-6733 FAX: 812-948-5047 e-Mail: info@SAMTEC.com code 55322</p>	
	<p>DO NOT SCALE DRAWING</p> <p>SHEET SCALE: 3:1</p>	<p>DESCRIPTION: LPAF SOCKET ASSEMBLY</p>
	<p>BY: R MUSSER 06/08/2009</p>	<p>DWG. NO. LPAF-XX-XX.X-X-XX-X-K-XR</p> <p>SHEET 2 OF 3</p>

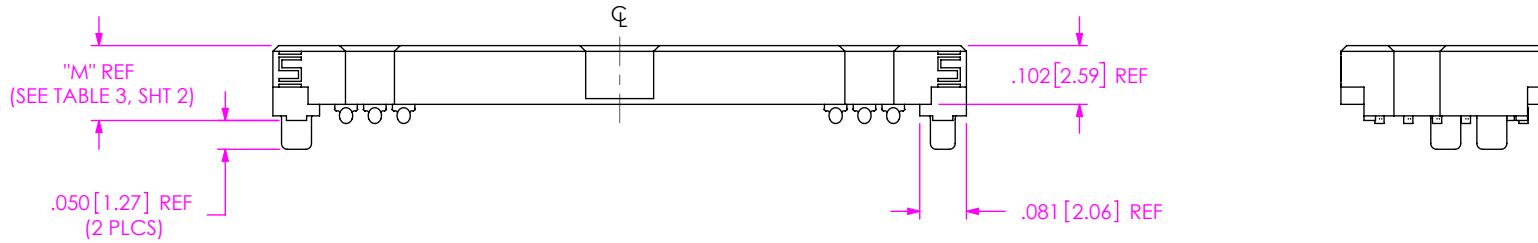

FIG 2
LPAF-20-03.5-X-06-X-X-K-XR SHOWN
(SOME FEATURES REMOVED FOR CLARITY)

TABLE 6

ROWS	DOT APPLICATOR POLYIMIDE TAPE CALLOUT	"N"	"P"					"Q"
			10 POS	20 POS	30 POS	40 POS	*50 POS	
-04	K-DOT-.256-.375-.005	.256 [6.50]	.224 [5.69]	.474 [12.04]	.724 [18.39]	.974 [24.74]	1.224 [31.09]	.004 [0.10]
-06	K-DOT-.354-.469-.005	.354 [8.99]	.175 [4.45]	.425 [10.80]	.675 [17.15]	.925 [23.50]	1.175 [29.85]	.005 [0.13]
-08	K-DOT-.460-.550-.005	.460 [11.68]	.122 [3.10]	.372 [9.45]	.622 [15.80]	.872 [22.15]	1.122 [28.50]	.002 [0.05]
-10	K-DOT-.551-.625-.005	.551 [14.00]	.077 [1.96]	.327 [8.31]	.577 [14.66]	.827 [21.01]	1.077 [27.36]	.007 [0.18]

TABLE 7

LEAD STYLE	"R"
-03.0	0.115 [2.92]
-03.5	0.135 [3.43]

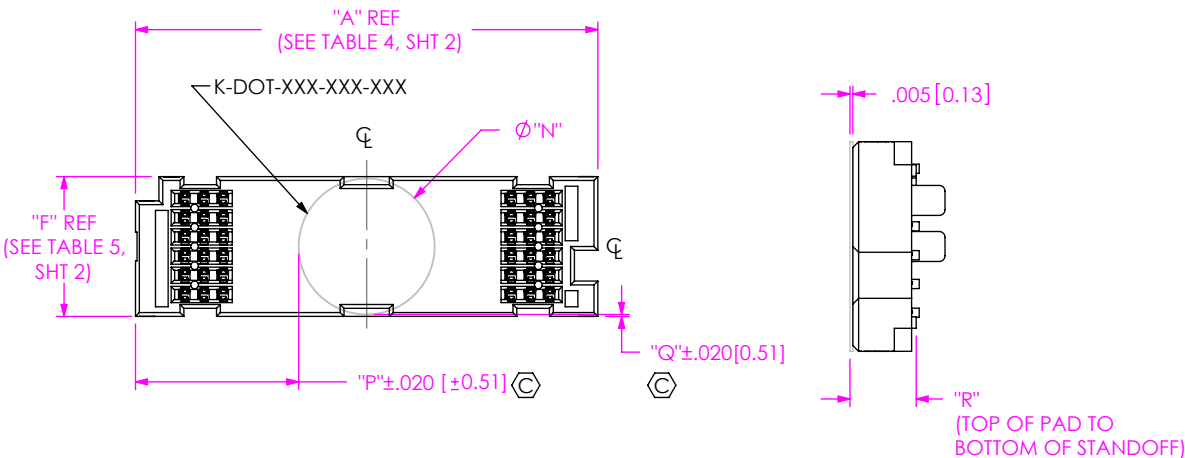

FIG 3
-K: POLYIMIDE PAD
(USE K-DOT-XXX-XXX-XXX)
LPAF-20-03.0-X-06-X-K-XR SHOWN
(SOME FEATURES REMOVED FOR CLARITY)

PROPRIETARY NOTE
THIS DOCUMENT CONTAINS CONFIDENTIAL AND PROPRIETARY INFORMATION AND ALL DESIGN, MANUFACTURING, REPRODUCTION, USE, PATENT RIGHTS AND SALES RIGHTS ARE EXPRESSLY RESERVED BY SAMTEC, INC. THIS DOCUMENT SHALL NOT BE DISCLOSED, IN WHOLE OR PART, TO ANY UNAUTHORIZED PERSON OR ENTITY NOR REPRODUCED, TRANSFERRED OR INCORPORATED IN ANY OTHER PROJECT IN ANY MANNER WITHOUT THE EXPRESS WRITTEN CONSENT OF SAMTEC, INC.



520 PARK EAST BLVD, NEW ALBANY, IN 47150
PHONE: 812-944-6733 FAX: 812-948-5047
e-Mail info@SAMTEC.com code 55322

DO NOT SCALE DRAWING
SHEET SCALE: 1:0.333333

DESCRIPTION:
LPAF SOCKET ASSEMBLY
DWG. NO.
LPAF-XX-XX.X-X-XX-X-K-XR
BY: R MUSSER 06/08/2009 SHEET 3 OF 3