

REVISONS		DATE	BY	APPV
DF	DO			
E		28JUL2009	CT	RL

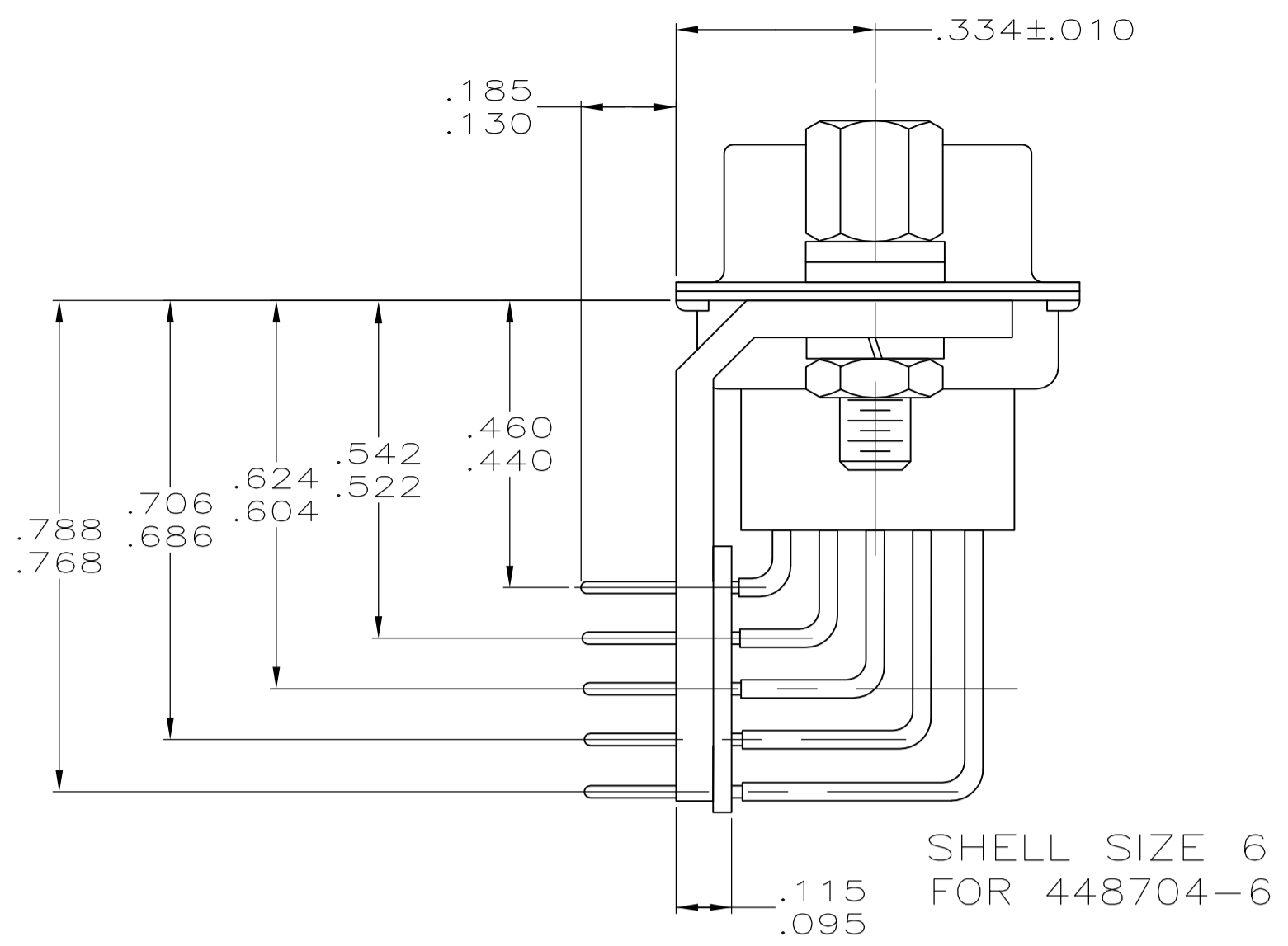

- SEE SHEET 2 FOR RECOMMENDED P.C. BOARD LAYOUT. TRUE POSITION TOLERANCE FOR P.C. BOARD LAYOUT IS .010 AT MAX MATERIAL CONDITION.
- THIS CONNECTOR ASSEMBLY MEETS THE REQUIREMENTS OF MIL-C-24308 AND MATES WITH ANY PLUG WITH SAME INSERT ARRANGEMENT.
- MARKED WITH .047-.062 HIGH CHARACTERS. FAR SIDE REFERS TO THE WIDE SIDE OF THE KEYSTONE. NEAR SIDE REFERS TO THE NARROW SIDE OF THE KEYSTONE. IF REAR SHELL IS TOO SMALL TO FIT ALL OF THE AMP MARKING, THEN MARKING SHALL BE LOCATED AS FOLLOWS:
  - TE PART NUMBER ON REAR SHELL, FAR SIDE.
  - "AMP" AND DATE CODE ON FRONT SHELL, FAR SIDE.
- EPOXY IS PERMITTED ON THE REAR OF THE CONNECTOR BUT, NOT ON THE MATING FACE OR SOLDER TAILS.
- SPACER CAN BOW UP OR DOWN BUT SHOULD NOT INTERFERE WITH THE ASSEMBLY OF CONNECTOR INTO THE PRINTED WIRING BOARD (PWB).

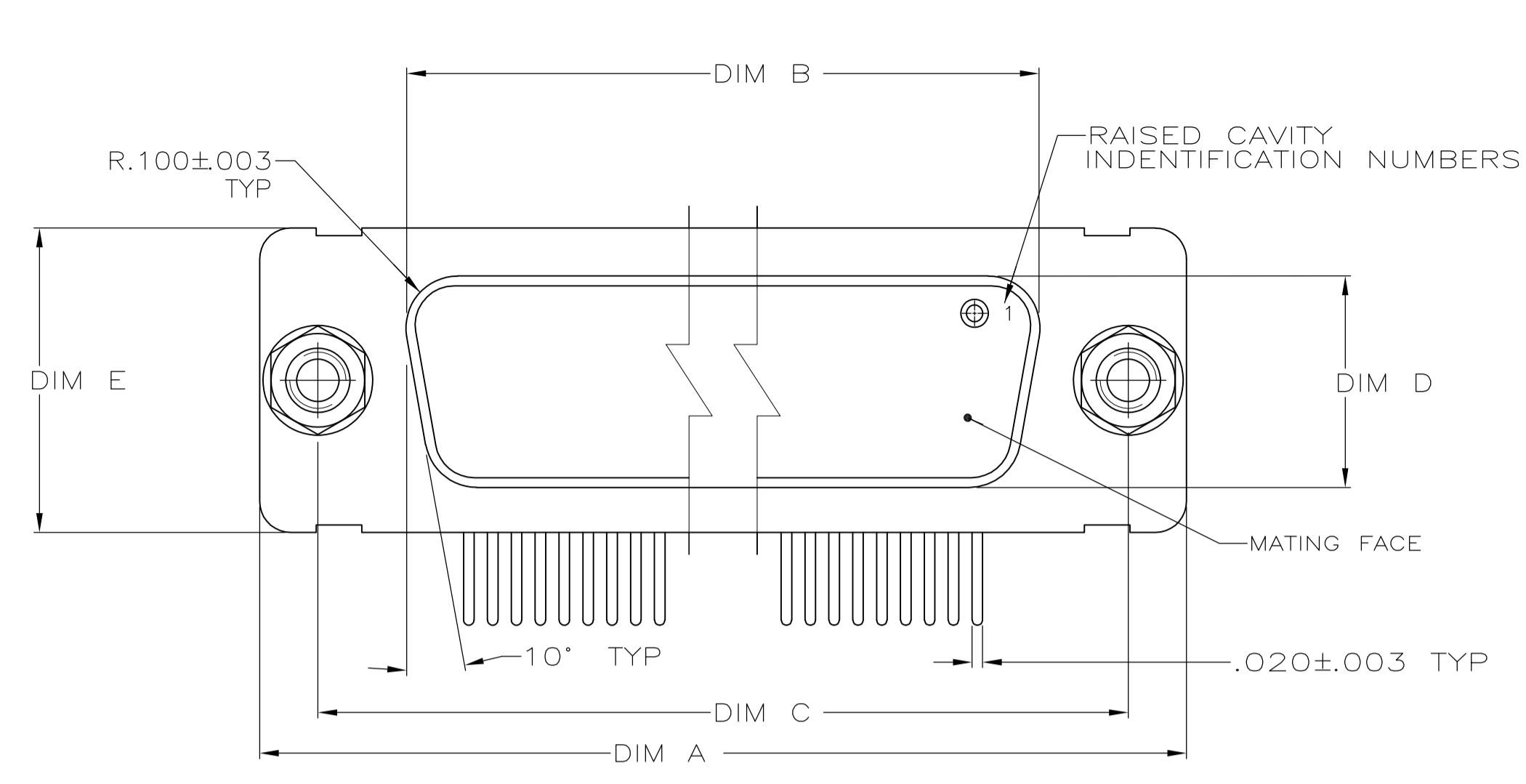
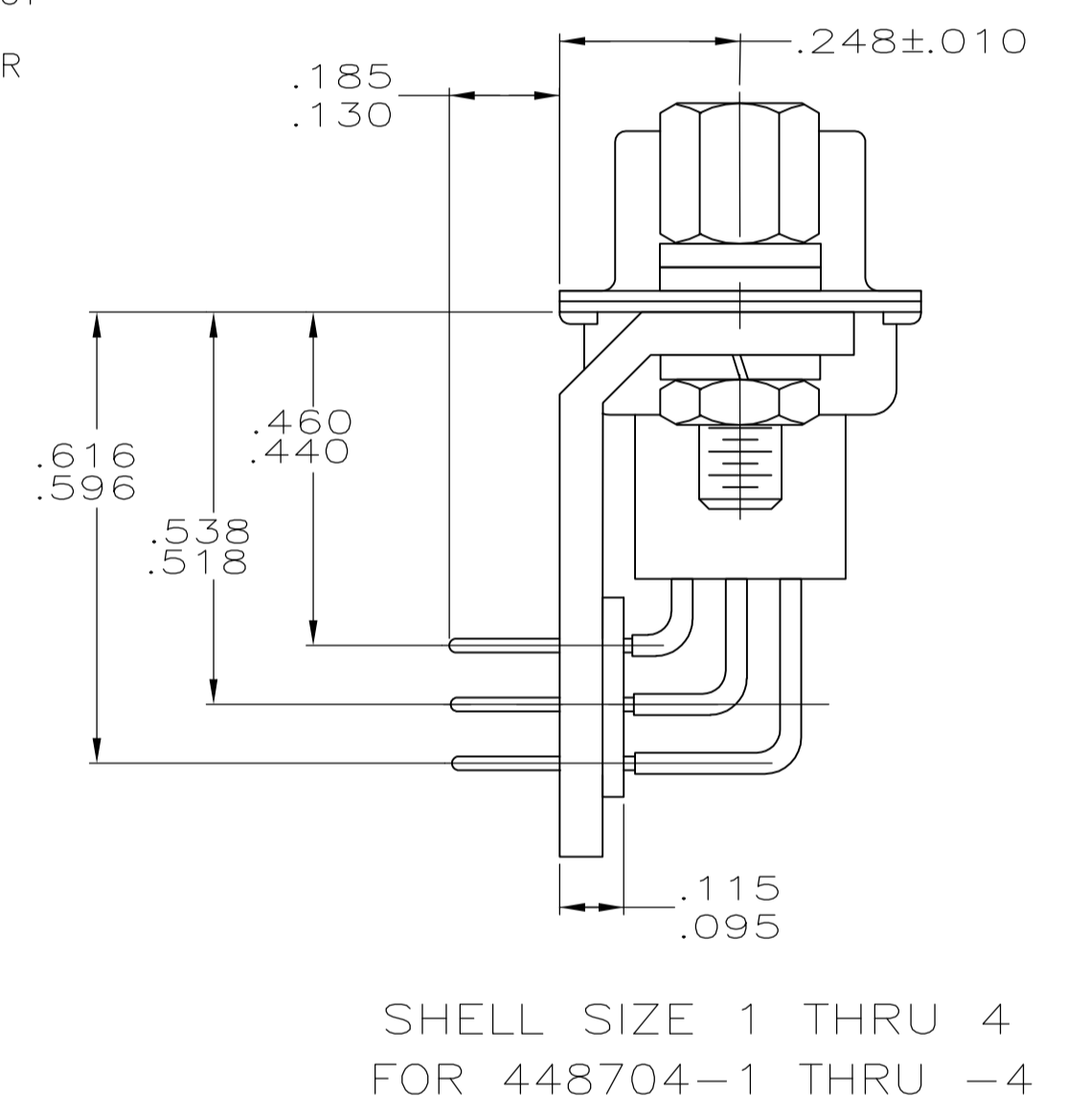
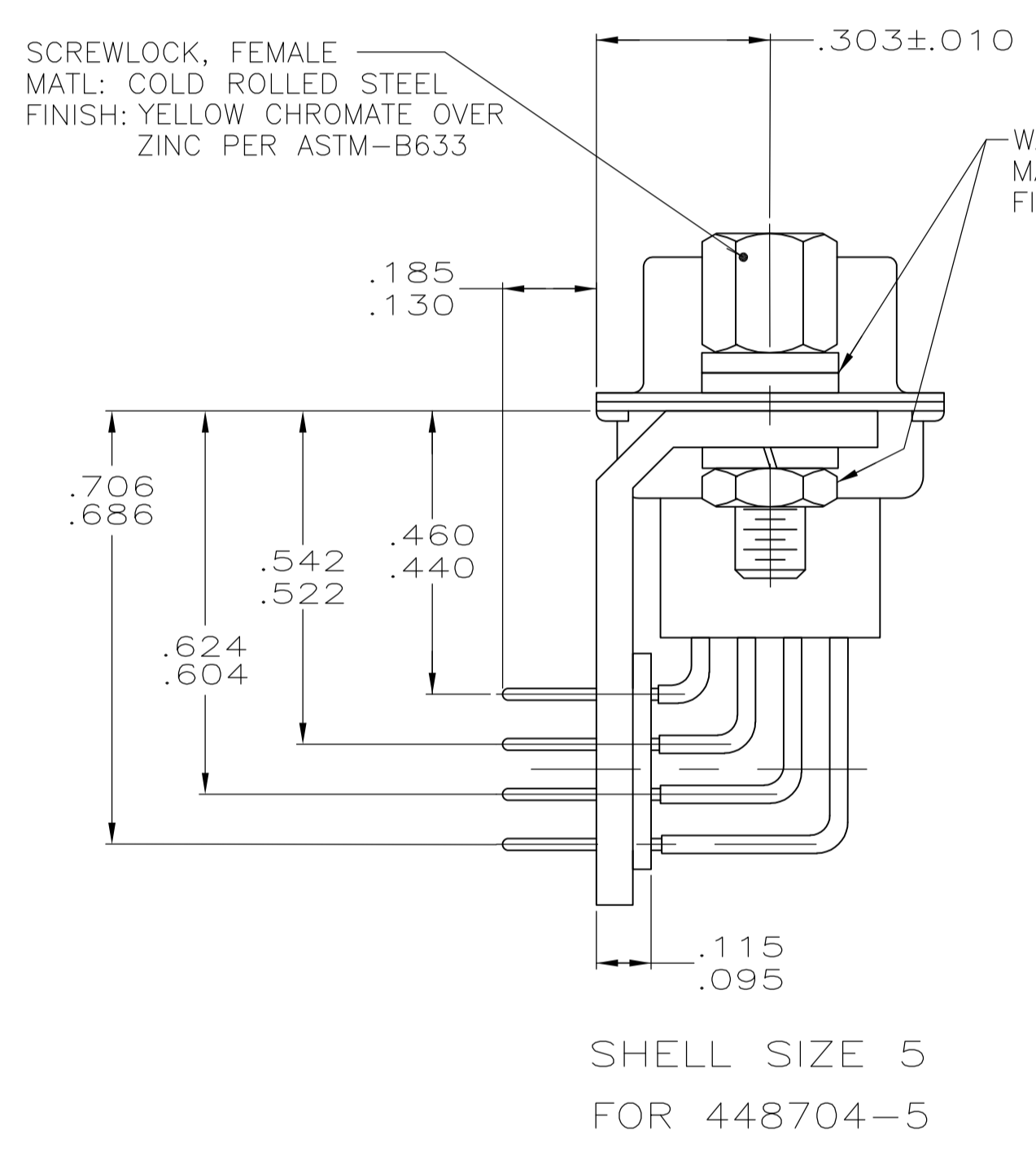
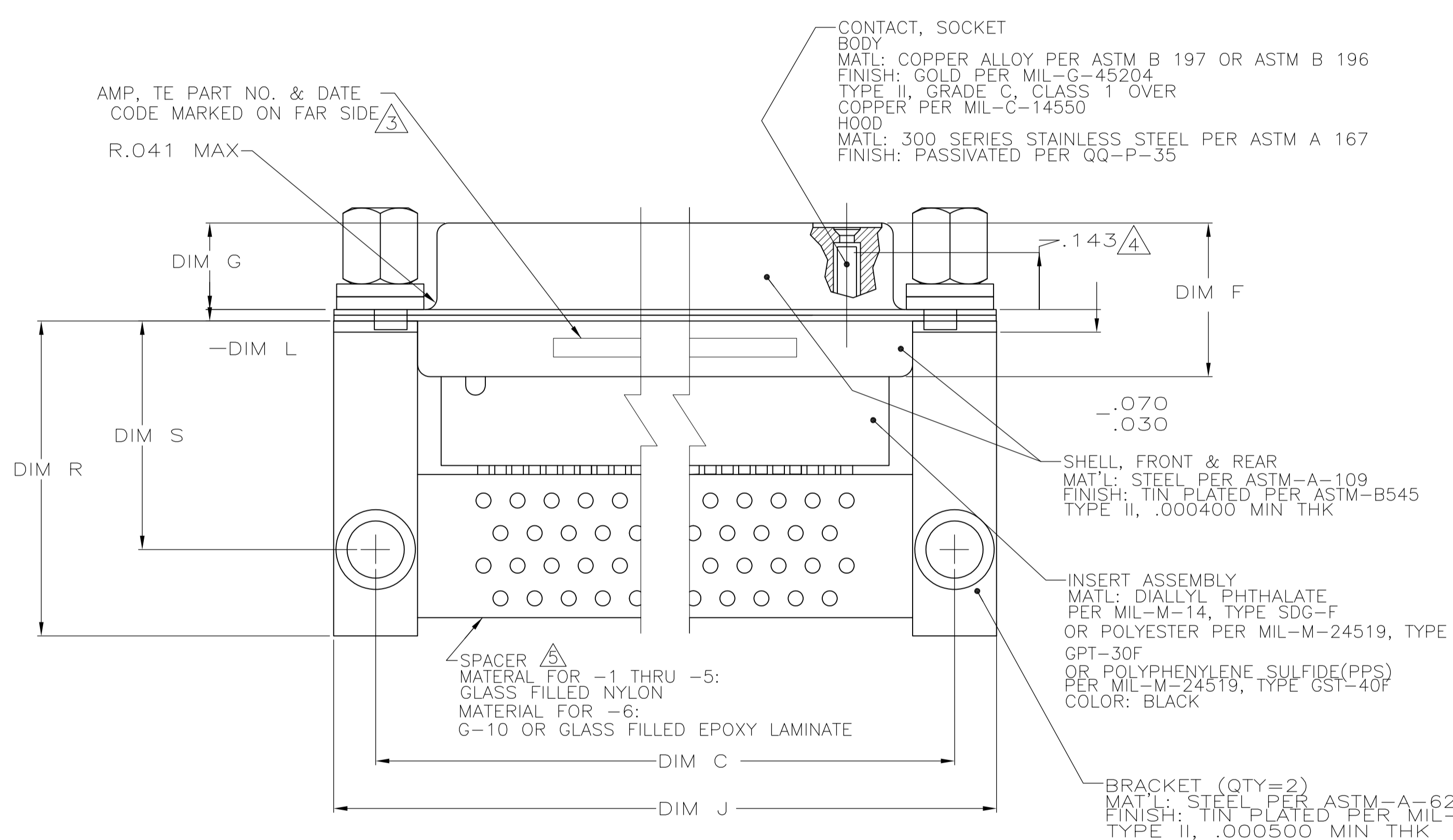

PRELIMINARY NOT RELEASED FOR PRODUCTION	.606	.790	2.726	.036	.230	.426	.668	.485	2.500	2.188	2.729	MS14004-1	104	6	448704-6
PRELIMINARY NOT RELEASED FOR PRODUCTION	.606	.790	2.626	.030	.230	.426	.605	.423	2.406	2.064	2.635	MS18277-2	78	5	448704-5
PRELIMINARY NOT RELEASED FOR PRODUCTION	.544	.740	2.720	.030	.230	.426	.494	.311	2.500	2.159	2.729	MS18276-2	62	4	448704-4
PRELIMINARY NOT RELEASED FOR PRODUCTION	.544	.740	2.077	.030	.230	.426	.494	.311	1.852	1.511	2.088	MS18275-2	44	3	448704-3
PRELIMINARY NOT RELEASED FOR PRODUCTION	.544	.740	1.532	.030	.234	.422	.494	.311	1.312	.971	1.541	MS18274-2	26	2	448704-2
PRELIMINARY NOT RELEASED FOR PRODUCTION	.544	.740	1.204	.030	.234	.422	.494	.311	.984	.643	1.213	MS18273-2	15	1	448704-1
	S±015	R±015	J±020	L±010	G±006	F±010	E±015	DIM D	DIM C	DIM B	A±015	INSERT ARRANGEMENT	NO. OF POSITIONS	SHELL SIZE	PART NUMBER

THIS DRAWING IS A CONTROLLED DOCUMENT.

DIMENSIONS: INCHES	TOLERANCES UNLESS OTHERWISE SPECIFIED:	0 PLC ± -	1 PLC ± -	2 PLC ± -	3 PLC ± .005	4 PLC ± -	ANGLES ± .4°
--------------------	----------------------------------------	-----------	-----------	-----------	--------------	-----------	--------------

MATERIAL: SEE CALLOUTS  
 FINISH: SEE CALLOUTS

APPROVED: CHAD BAKER  
 DATE: 7-13-01

NAME: CHAD BAKER  
 DATE: 7-13-01

SIZE: A1  
 CAGE CODE: 00779  
 DRAWING NO: 448704

SCALE: 4:1  
 SHEET: 1 OF 2  
 REV: E

LOC		DIST		REVISIONS			
DF	DO	F	LTR	DESCRIPTION	DATE	DN	APVD
-	-	-	-	SEE SHEET 1	-	-	-

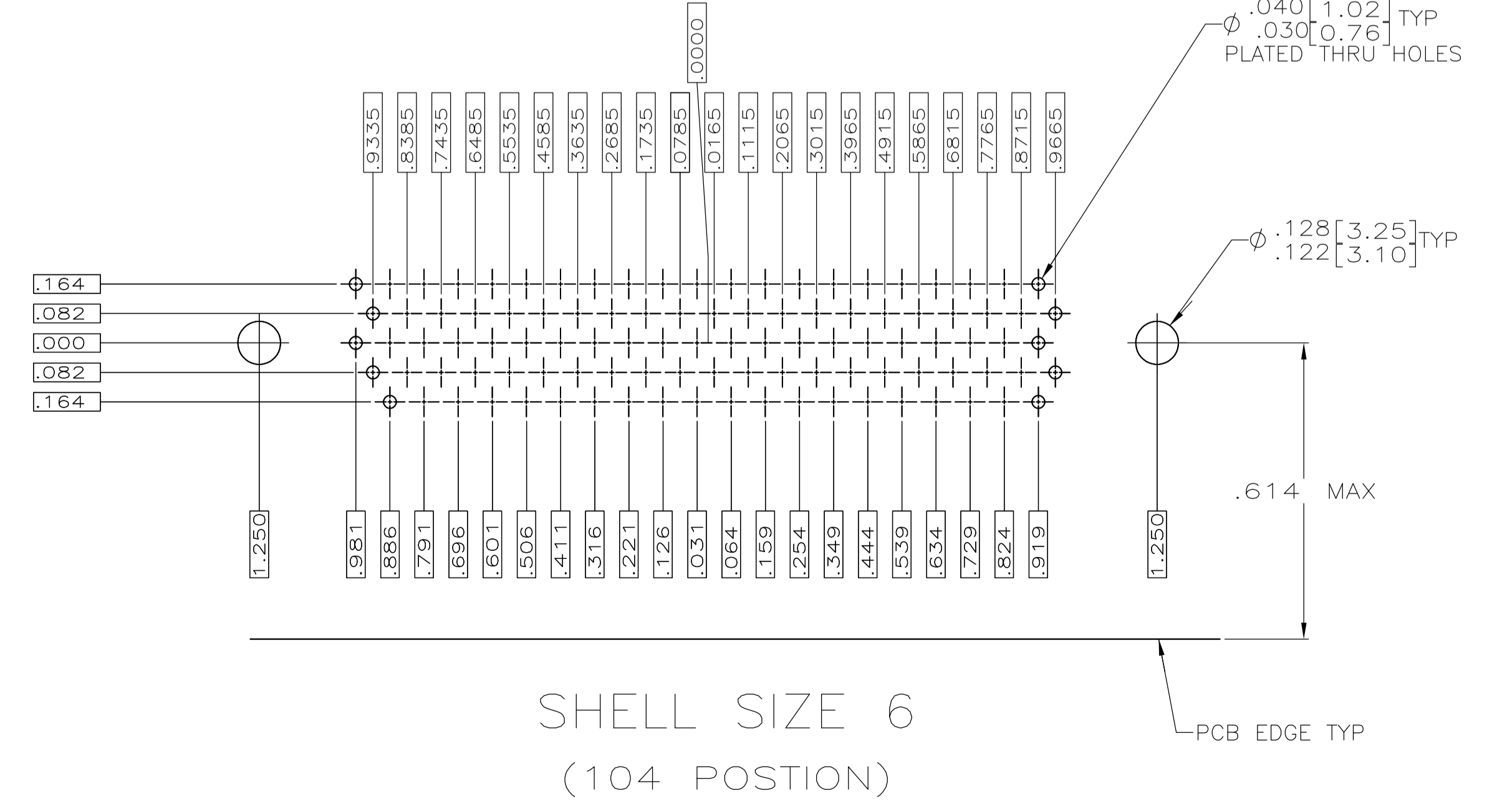
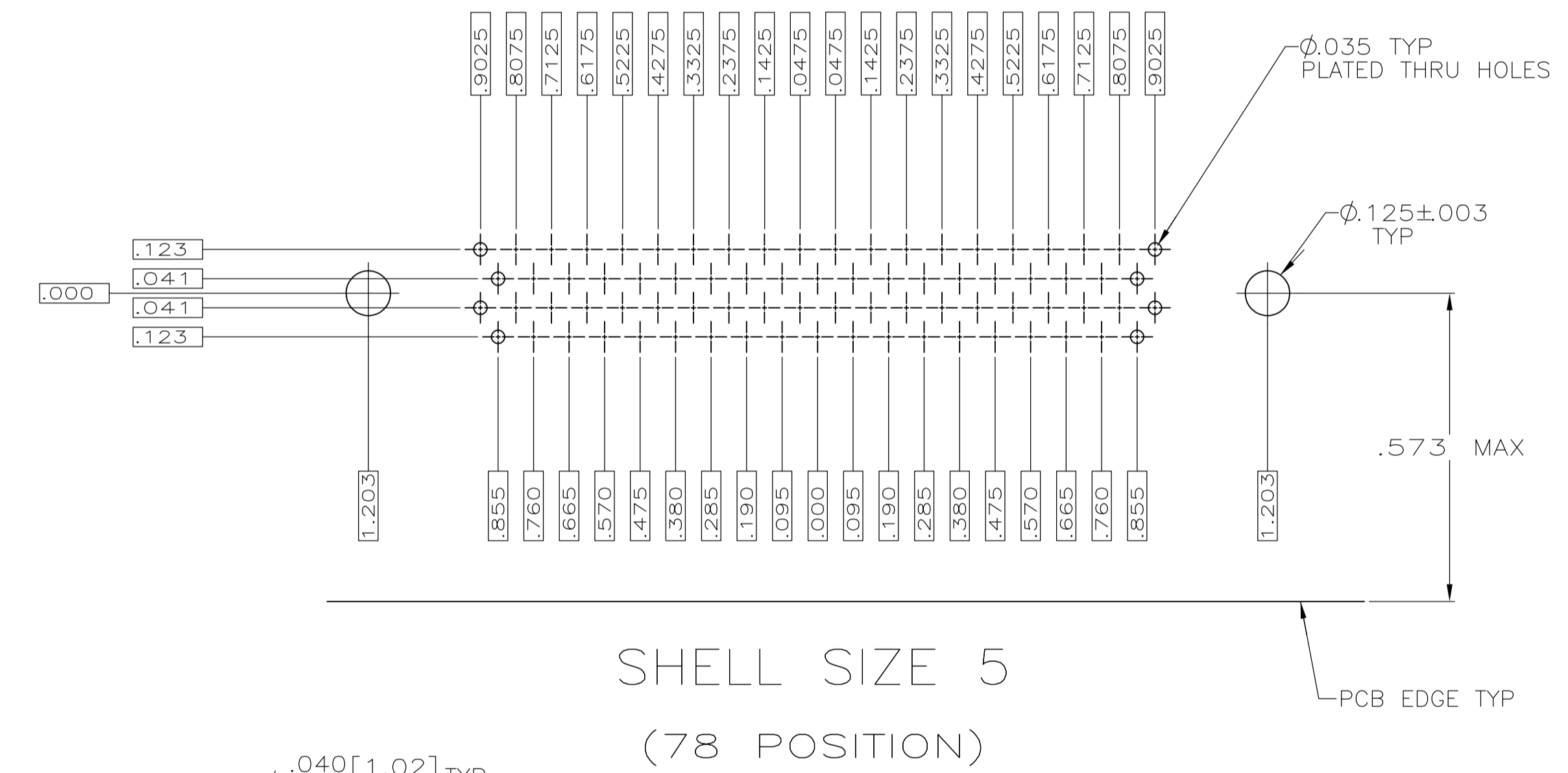
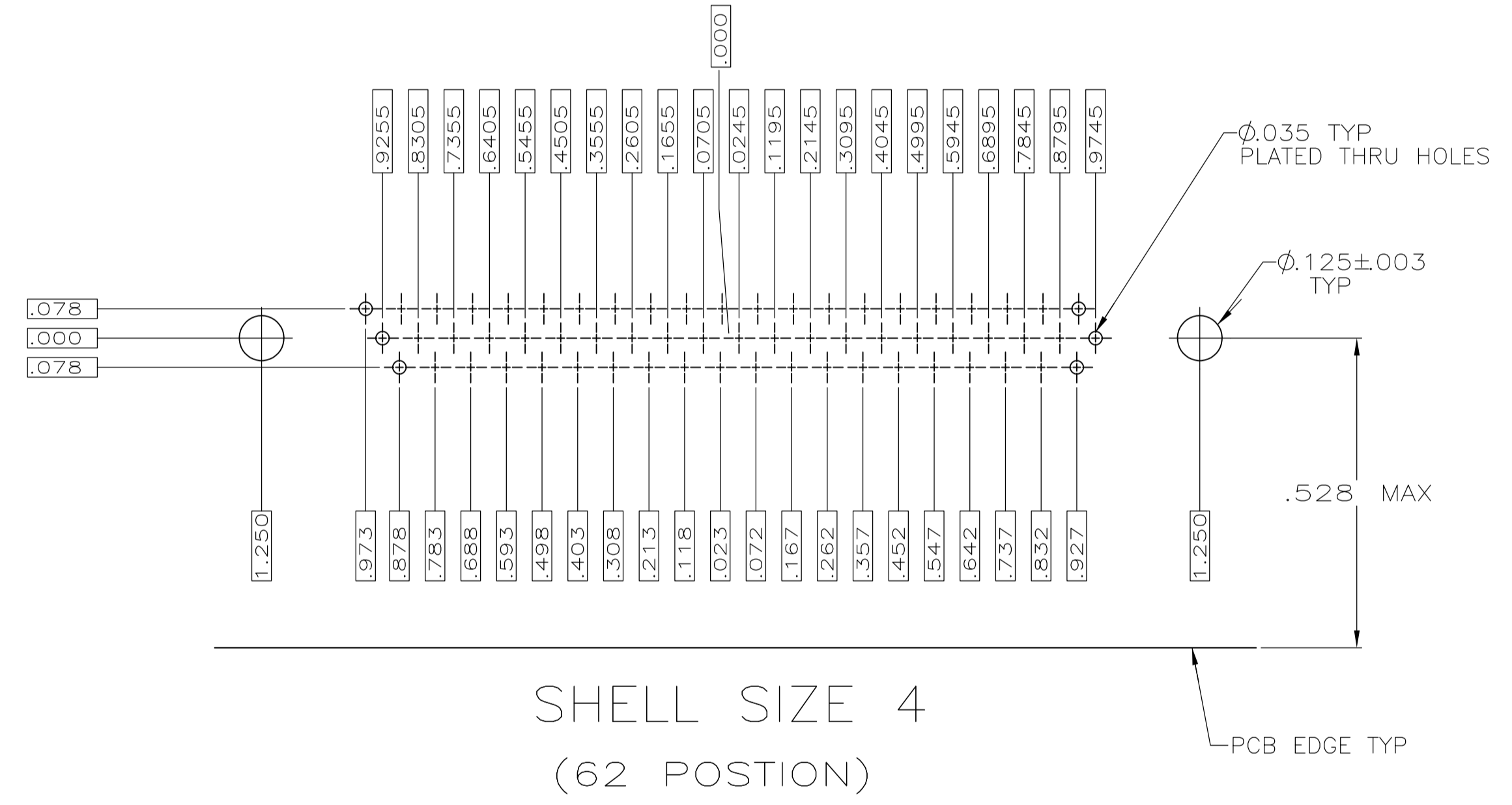
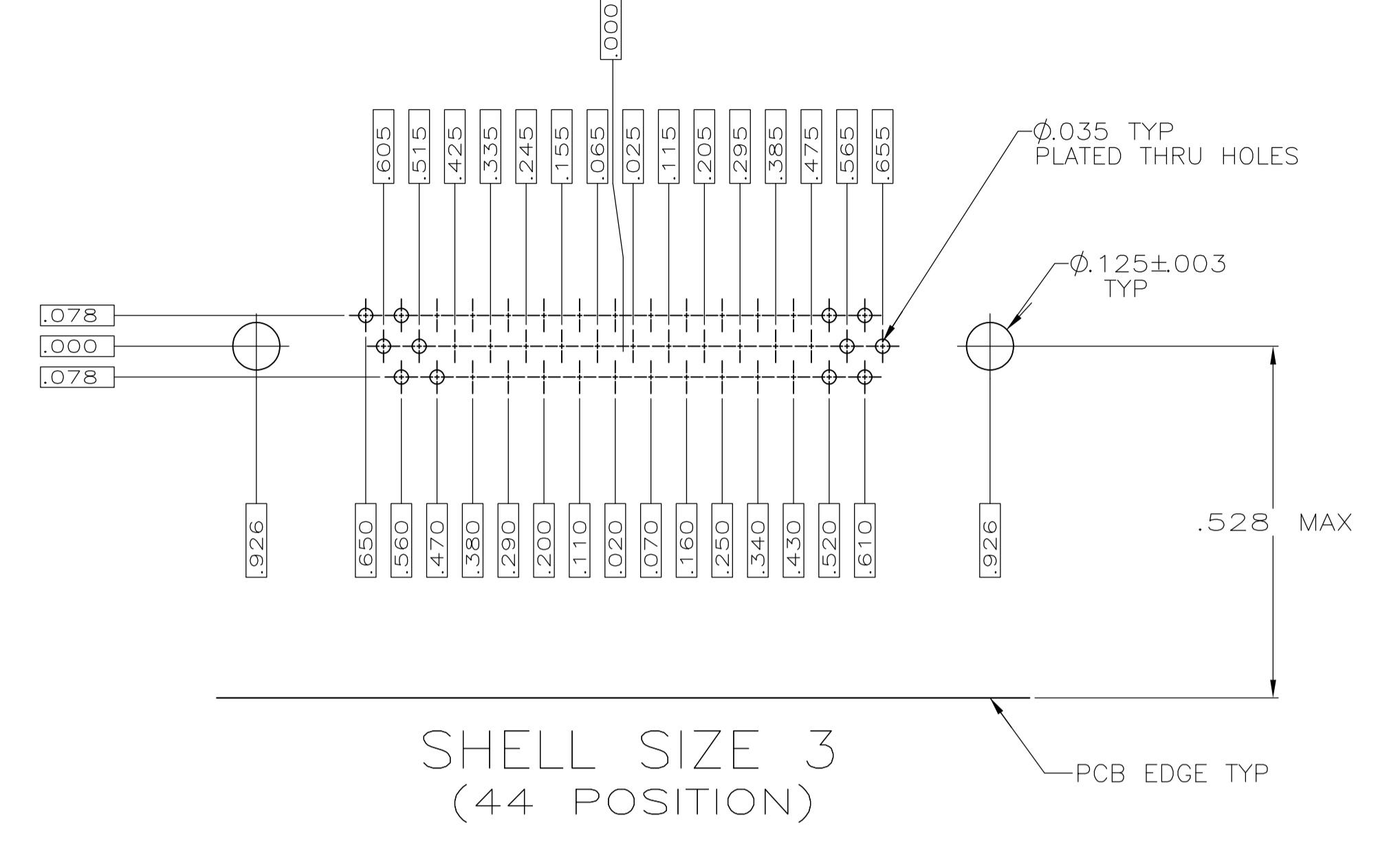
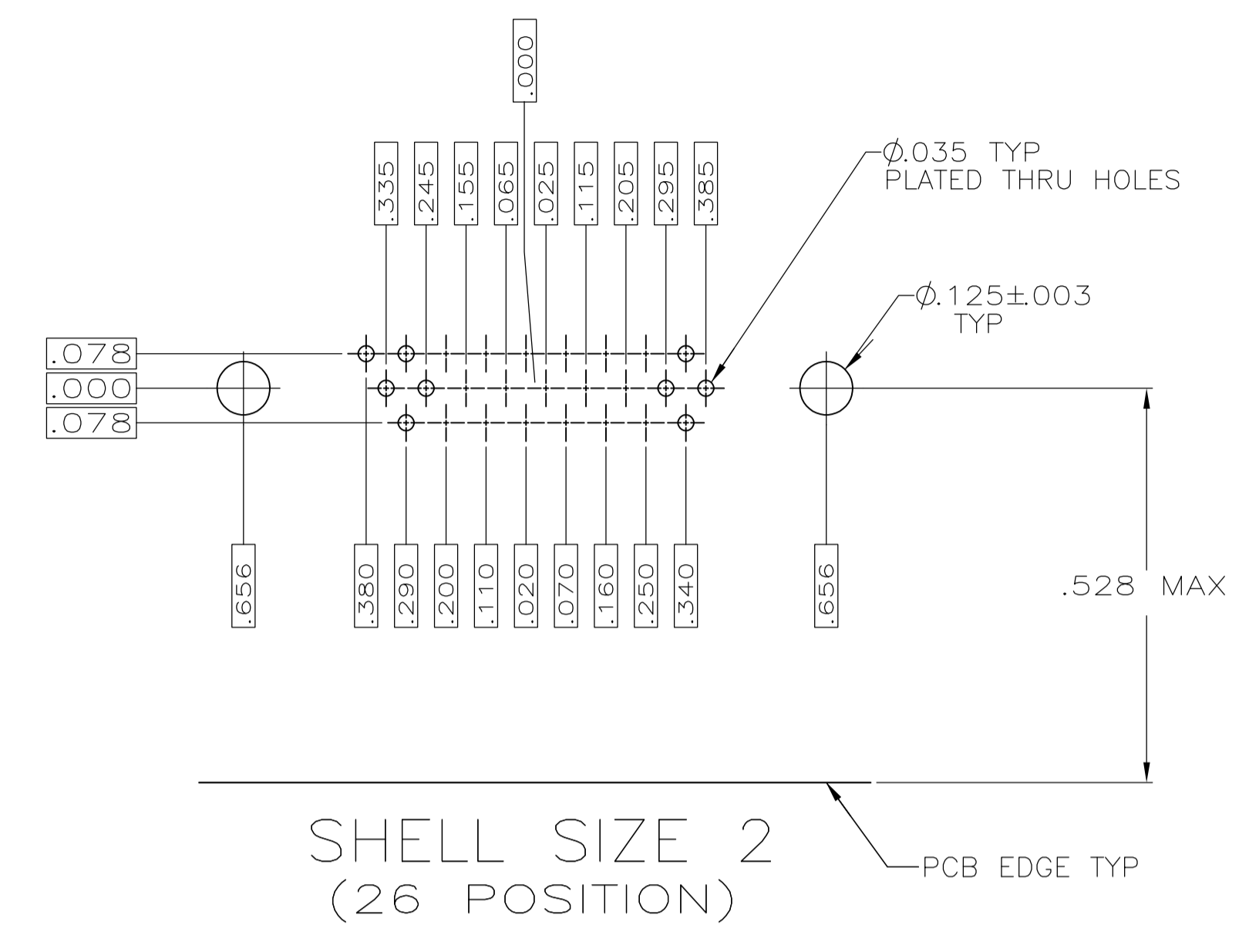
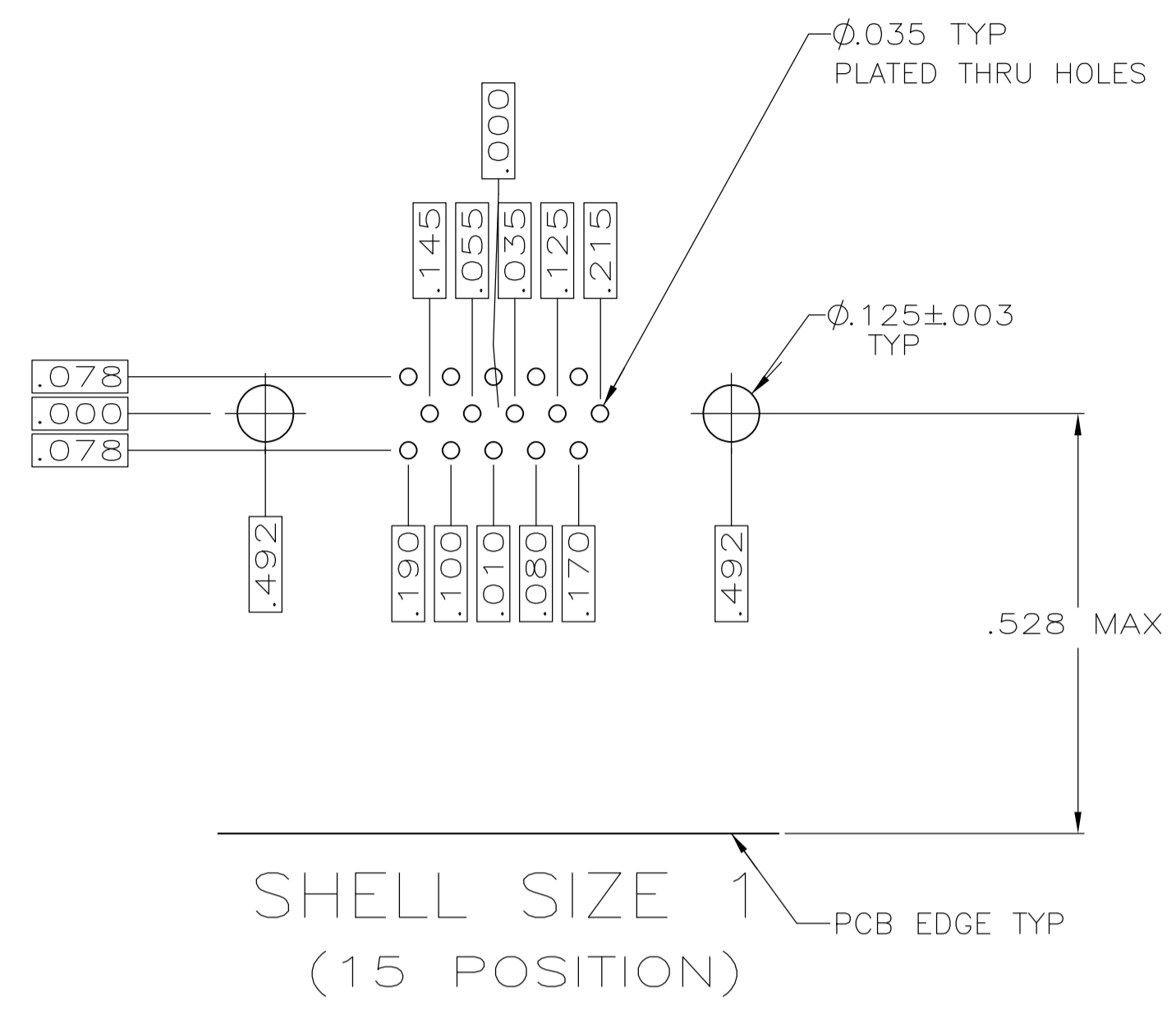

THIS DRAWING IS A CONTROLLED DOCUMENT.		DIN C.C.THOMAS 7-13-01	Tyco Electronics Tyco Electronics Corporation Harrisburg, PA 17105-3608
DIMENSIONS: INCHES		CHK CHAD BAKER 7-13-01	
TOLERANCES UNLESS OTHERWISE SPECIFIED:		APVD CHAD BAKER 7-13-01	NAME AMPLIMITE RCPT ASSY, SERIES 90, RIGHT ANGLE WITH FEMALE SCREWLOCKS SHELL SIZES 1 THRU 5
MATERIAL SEE CALLOUTS		FINISH SEE CALLOUTS	SIZE A1
CUSTOMER DRAWING		WEIGHT -	CAGE CODE 00779
SCALE 4:1		SHEET 2 OF 2	REV E