



- Ethernet based LAN, WAN and other networking applications
- Cw/w: 50PF Typ @ 100KHz, 0.2V
- Polarity: 1-20, 4-17, 6-15, 9-12 In-Phase
- LL: 0.5μH Max @ 100KHz, 0.2V
- DCR: 0.9Ω Max
- Operating Temp: 0°C to 70°C



Electrical Specifications @ 25°C

Part Number	OCL(uH Min) @ 100kHz, 200mV	Turns Ratio chip: cable (±5%)	Insertion Loss (dB Max)	Return Loss (dB Min)			
	With 8mA DC Bias			0.3-30MHz	40MHz	50MHz	60-80MHz
AHTA-2001S	350	1CT:1CT(TX)/1CT:1CT(RX)	-1.1	-18	-14.4	-13.1	-12

Electrical Specifications @ 25°C

Part Number	Common Mode Rejection (dB Min)			Cross Talk (dB Min)		Isolation HI-POT (Vrms) 60S
	0.3-30MHz	60MHz	80-100MHz	0.3-30MHz	60-100MHz	
AHTA-2001S	-40	-35	-30	-42	-33	1500

All specifications subject to change without notice.

MECHANICAL

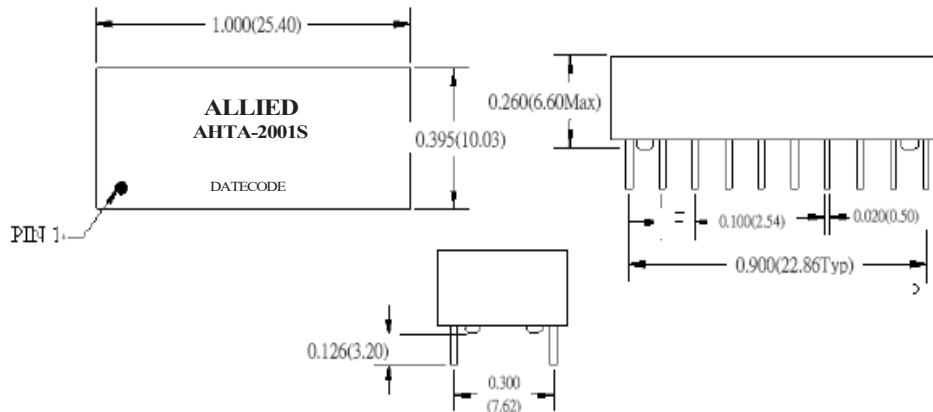

SCHEMATICS

