

P	LTR	DESCRIPTION	DATE	DWN	APVD
G		REVISED EC 0G3B-0137-04	22MAR2004	SW	CR
G1		ECR-20-002501	06OCT2020	DV	PS

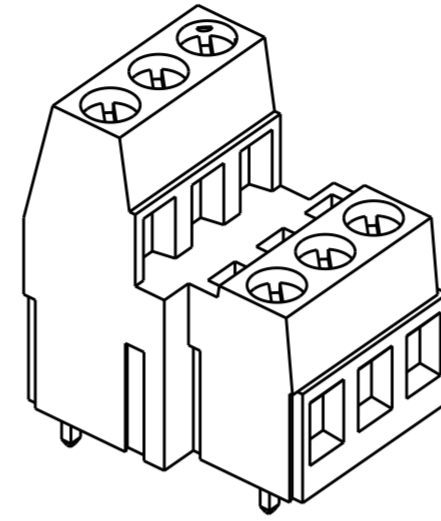

282888-3 AS SHOWN

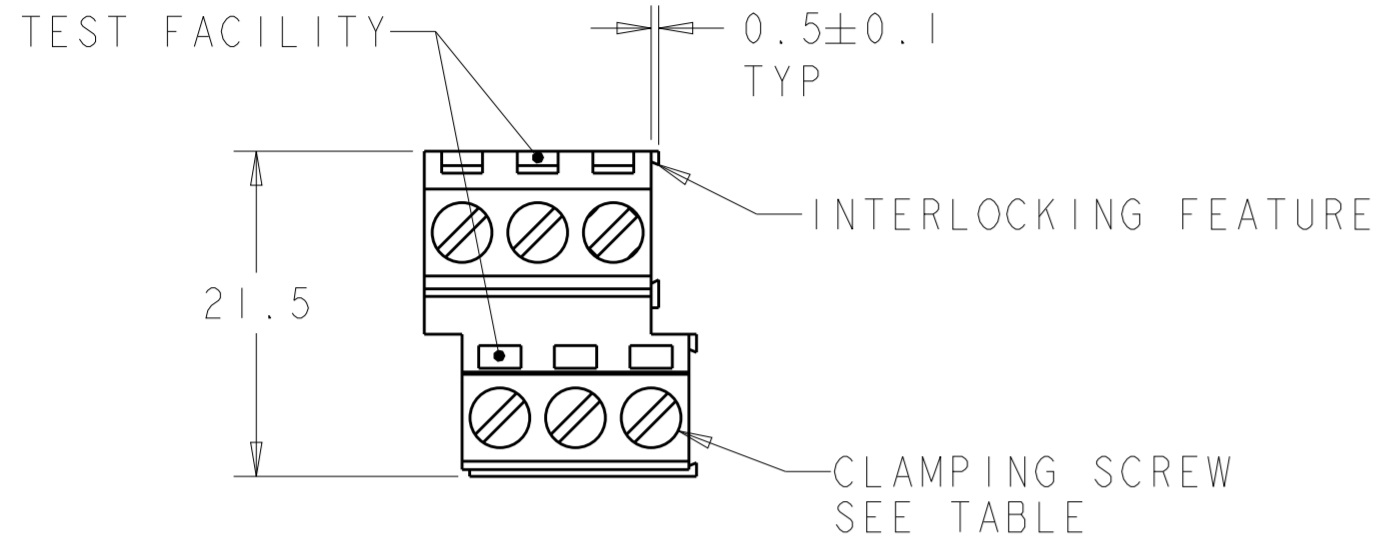
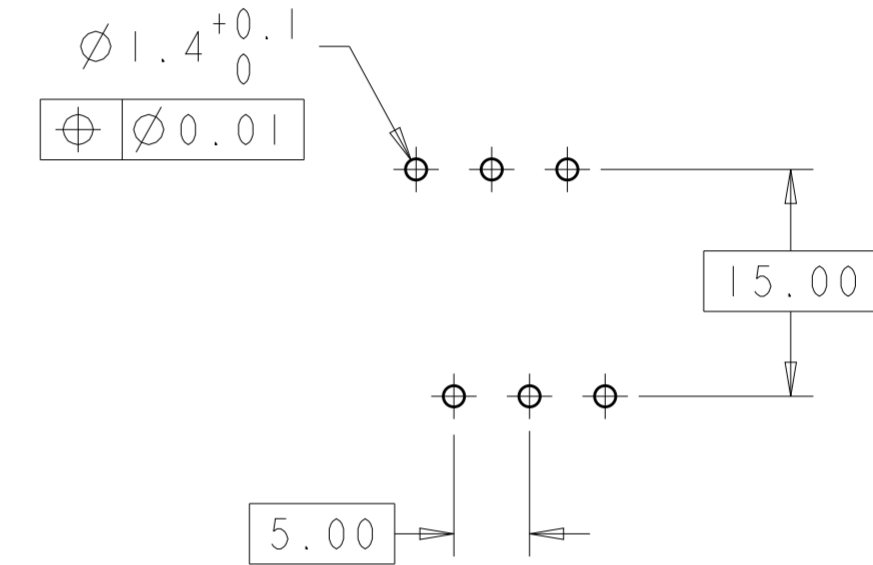

RECOMMENDED PC BOARD LAYOUT

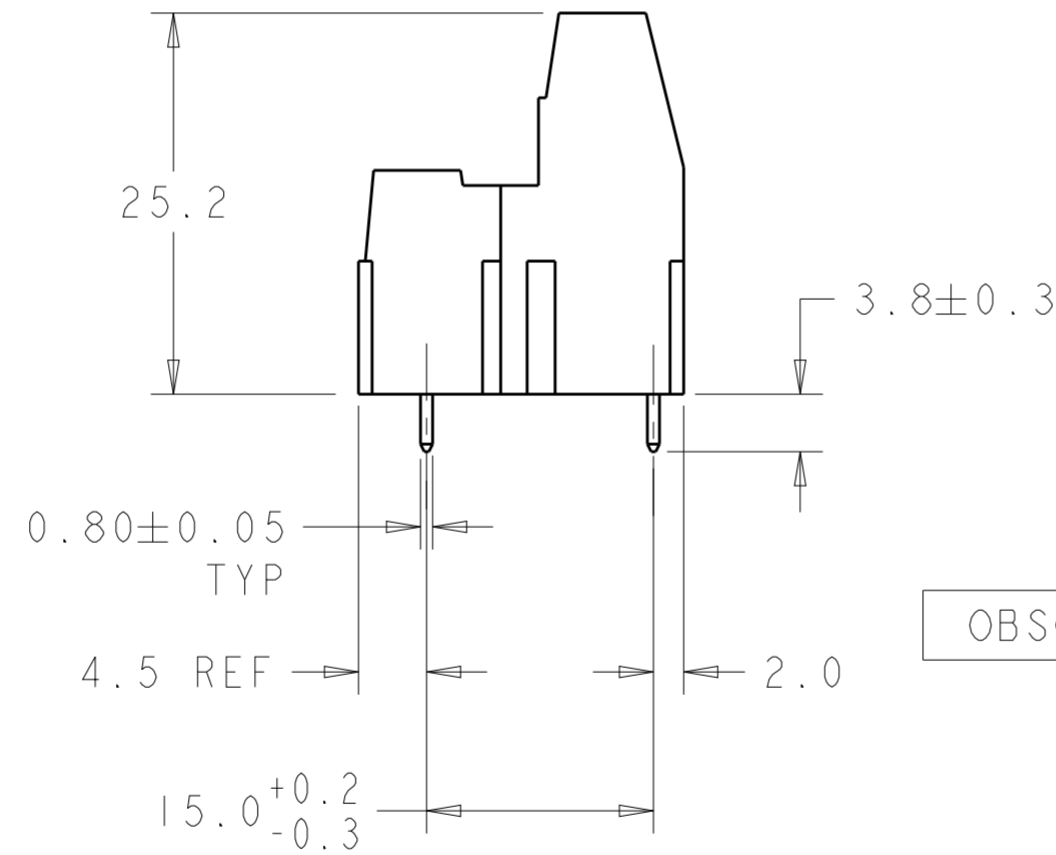
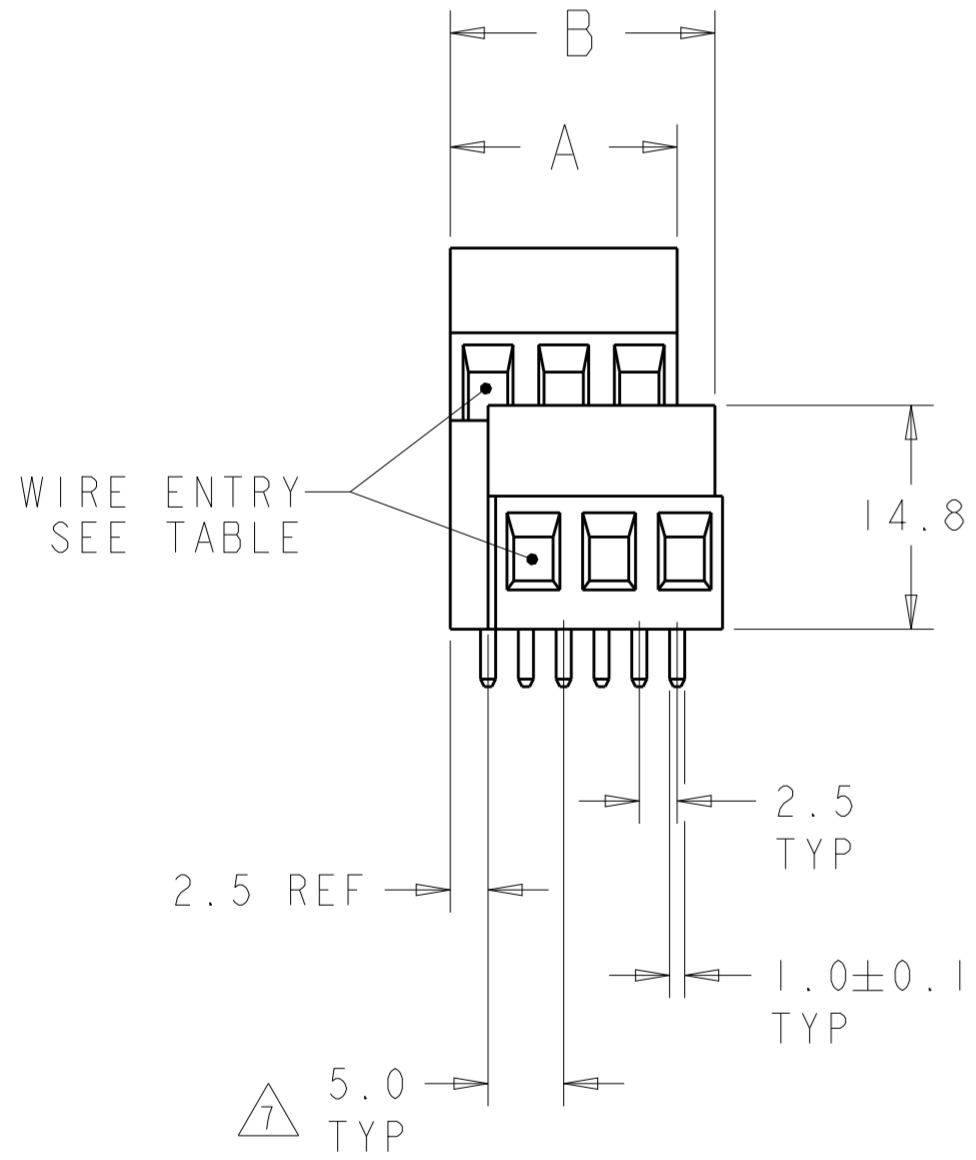

OBSOLETE

-	-	-	52.5	50.0	10	1-282888-1
-	-	-	42.5	45.0	9	1-282888-0
-	SEE SHT 2	-	47.5	45.0	9	282888-9
-	-	13	17.5	15.0	3	282888-8
-	-	13	47.5	45.0	9	282888-7 11
SEE SHT 2	-	-	17.5	15.0	3	282888-6
-	SEE SHT 2	-	72.5	70.0	14	282888-5 10
-	SEE SHT 2	-	97.5	95.0	19	282888-4 9
-	-	-	17.5	15.0	3	282888-3
-	-	-	12.5	10.0	2	282888-2
WIRE ENTRY	MARKING	CLAMPING SCREWS	B	A	NO. OF POSN	PART NUMBER

THIS DRAWING IS A CONTROLLED DOCUMENT.

DWN S. WELDON 01NOV2000
 CHK D. BIEVENOUR 01NOV2000
 APVD D. BIEVENOUR 01NOV2000

STE TE Connectivity

NAME: TERMINAL BLOCK, PCB MOUNT
 1ST AND 2ND LEVEL, STACKING
 W/INTERLOCK, 5.00mm PITCH

SIZE: A2 CAGE CODE: 00779 DRAWING NO: C-282888 RESTRICTED TO: -

MATERIAL: FINISH:

TOLERANCES UNLESS OTHERWISE SPECIFIED:
 0 PLC ±-
 1 PLC ±.3
 2 PLC ±.25
 3 PLC ±.
 4 PLC ±.
 ANGLES ±2

PRODUCT SPEC: -
 APPLICATION SPEC: -
 WEIGHT: -

CUSTOMER DRAWING SCALE: 1:1 SHEET: 3 OF 3 REV: G1

REVISIONS				
P	LTR	DESCRIPTION	DATE	APVD
-		SEE SHEET 1	-	-

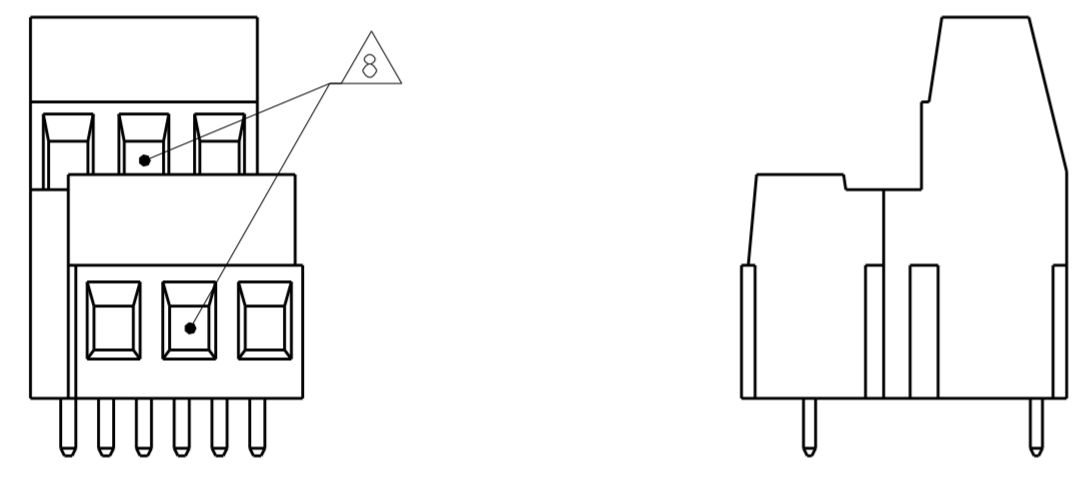
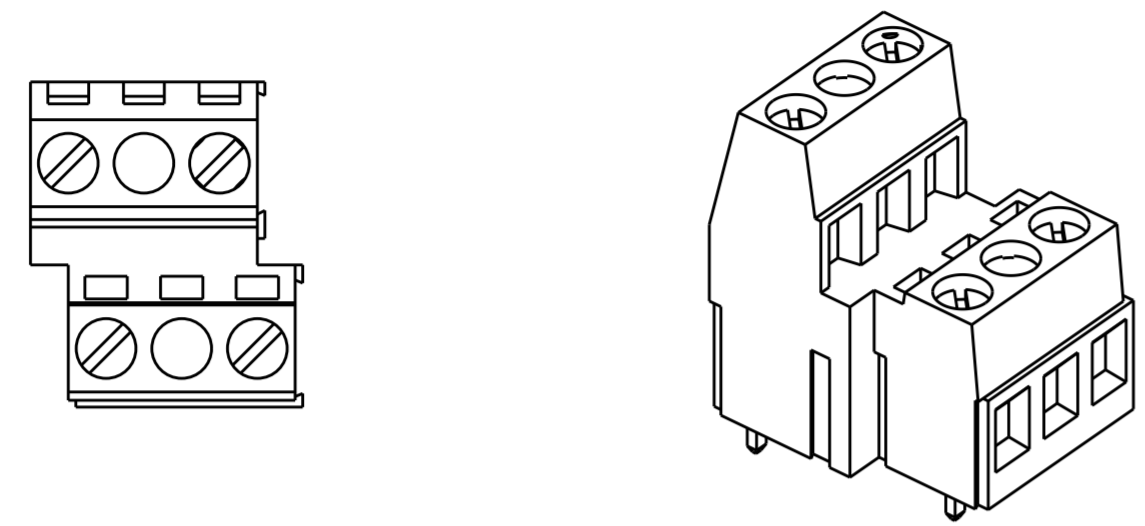

282888-6 AS SHOWN

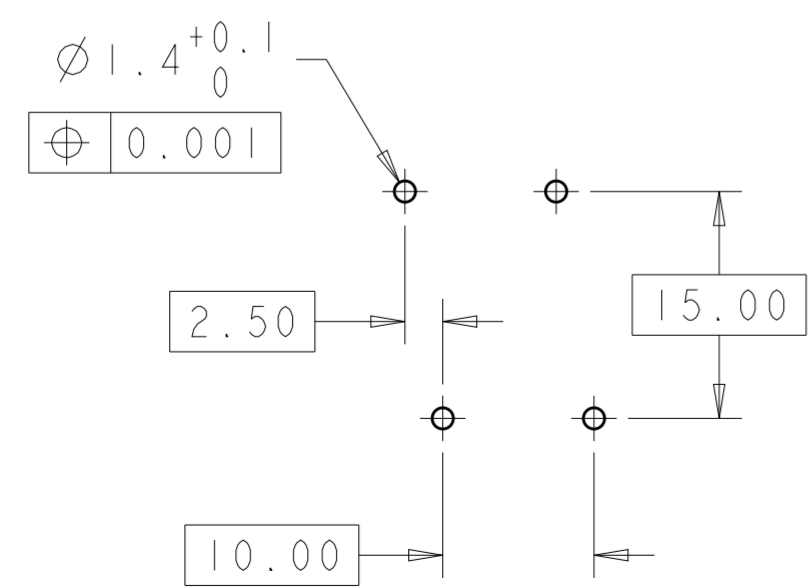

RECOMMENDED PC BOARD LAYOUT

CAVITY ID
INK MARKED WHITE

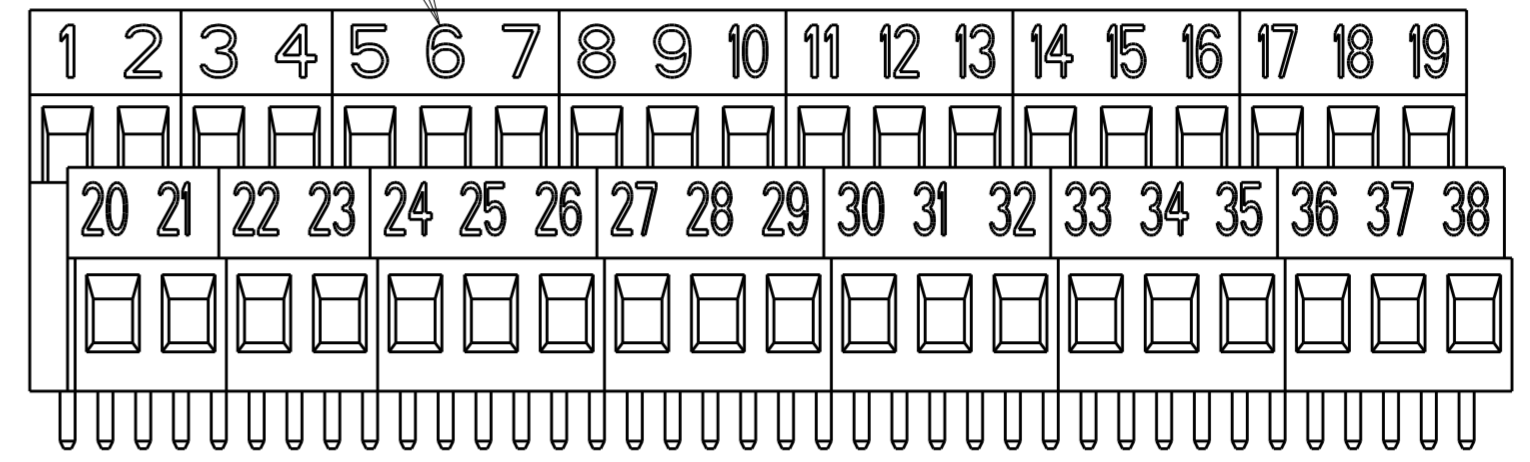

282888-4 AS SHOWN

CAVITY ID
INK MARKED WHITE

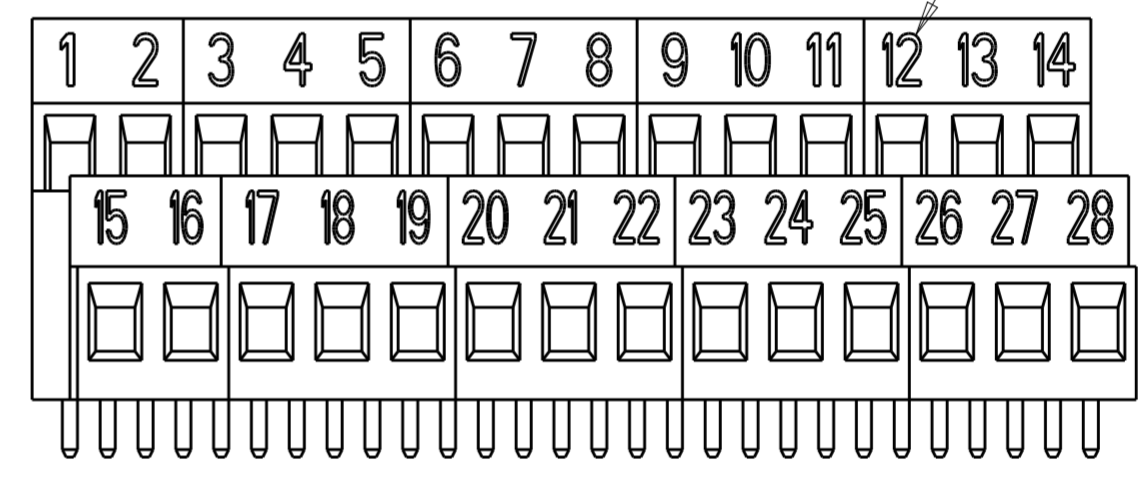

282888-5 AS SHOWN

LINE
INK MARKED WHITE

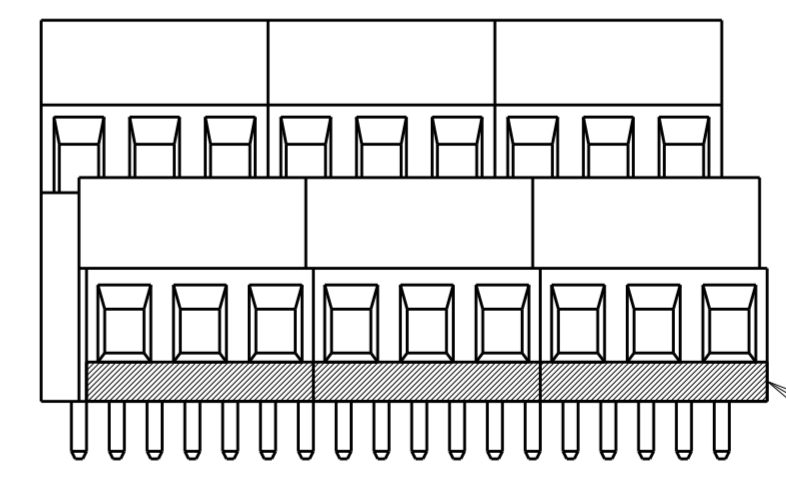

282888-9 AS SHOWN

THIS DRAWING IS A CONTROLLED DOCUMENT.		DWN S. WELDON 01NOV2000	STE TE Connectivity	
DIMENSIONS: mm		CHK D. BIEVENOUR 01NOV2000		
TOLERANCES UNLESS OTHERWISE SPECIFIED: 0 PLC ±.3 1 PLC ±.25 2 PLC ±.25 3 PLC ±. 4 PLC ±. ANGLES ±2 FINISH		APVD D. BIEVENOUR 01NOV2000	NAME TERMINAL BLOCK, PCB MOUNT 1ST AND 2ND LEVEL, STACKING W/INTERLOCK, 5.00mm PITCH	
MATERIAL		PRODUCT SPEC -	SIZE A200779	DRAWING NO C-282888
		APPLICATION SPEC -	RESTRICTED TO -	
		WEIGHT -	SCALE 2:1	SHEET 2 OF 3
		CUSTOMER DRAWING	REV G1	

REVISIONS

P	LTR	DESCRIPTION	DATE	DWN	APVD
-		SEE SHEET 1	-	-	-

- 1. MATERIALS AND FINISH
HOUSING: PA 6-6, UL 94-V0.
COLOR: GREEN.
CLAMP: BRASS, NICKEL PLATED.
TERMINAL: BRASS, TIN PLATED.
CLAMPING SCREW: M3, BRASS, NICKEL PLATED.
- 2. SUITABLE FOR 1,6-2,4mm PC BOARD THICKNESS.
- 3. END-TO-END STACKABLE W/INTERLOCK WITHOUT LOSS OF CENTERLINE SPACING.
- 4. WIRE SIZE RANGE
12-30 AWG
- 5. RECOGNIZED UNDER THE COMPONENT PROGRAM OF UNDERWRITERS LABORATORIES INC., FILE N° E60677.
- 6. IMQ CERTIFICATE WITH SURVEILLANCE IN CONFORMITY WITH IEC 998-1/998-2-1.
- 7. NOT CUMULATIVE TOLERANCE.
- 8. BLOCKED CAVITY, COLOR: RED.
- 9. 282888-4 OBTAINED BY ASSEMBLING (5) 282888-3 AND (2) 282888-2 END TO END.
- 10. 282888-5 OBTAINED BY ASSEMBLING (4) 282888-3 AND (1) 282888-2 END TO END.
- 11. 282888-7 OBTAINED BY ASSEMBLING AND GLUING TOGETHER (3) 282888-3 END TO END.
- 12. INK MARKING, COLOR: WHITE.
- 13. CLAMPING SCREWS IN TORQUED DOWN POSITION.

THIS DRAWING IS A CONTROLLED DOCUMENT.		DWN S. WELDON 01NOV2000	 TE Connectivity	
DIMENSIONS: mm		CHK D. BIEVENOUR 01NOV2000		
TOLERANCES UNLESS OTHERWISE SPECIFIED: 0 PLC ±- 1 PLC ± 3 2 PLC ±.25 3 PLC ±- 4 PLC ±- ANGLES ±2		APVD D. BIEVENOUR 01NOV2000	NAME TERMINAL BLOCK, PCB MOUNT 1ST AND 2ND LEVEL, STACKING W/INTERLOCK, 5.00mm PITCH	
MATERIAL		PRODUCT SPEC -	SIZE A200779	CAGE CODE C-282888
FINISH		APPLICATION SPEC -	DRAWING NO C-282888	RESTRICTED TO -
		WEIGHT -	SCALE 1:1 SHEET 3 OF 3 REV G1	
		CUSTOMER DRAWING		