

- 1 FOR USE WITH 2.36 [.093] MINIMUM THICK PRINTED CIRCUIT BOARD. REFER TO APPLICATION SPECIFICATION FOR PRINTED CIRCUIT BOARD LAYOUT DIMENSIONS AND FINISH RECOMMENDATIONS.
- 2 HOUSING: NYLON OR POLYESTER, UL 94V-0 RATED, GLASS FILLED, BLACK.
- 3 CONTACTS: COPPER ALLOY
- 4 SHELL: CARBON STEEL
- 5 SCREWLOCKS: BRASS
- 6 SCREWLOCKS: UNPLATED.
- 7 SHELL: 5.08µm [.000200] MIN TIN OVER 2.54µm [.000100] MIN COPPER.
- 8 CONTACTS: 0.76µm (.000030) MINIMUM GOLD PLATE IN MATING AREA, 2.54µm (.000100) MINIMUM TIN PLATE ON COMPLIANT PIN, 1.27µm (.000050) MINIMUM NICKEL UNDERPLATE ON ENTIRE CONTACT.  
 -OR-  
 GOLD FLASH OVER PALLADIUM-NICKEL PLATE, 0.76µm (.000030) MINIMUM TOTAL IN MATING AREA, 2.54µm (.000100) MINIMUM TOTAL TIN PLATE ON COMPLIANT PIN, 1.27µm (.000050) MINIMUM NICKEL UNDERPLATE ON ENTIRE CONTACT.
- 9 DATUMS AND BASIC DIMENSIONS ESTABLISHED BY CUSTOMERS.
- 10 OBSOLETE PARTS: OBSOLETE CIS STREAMLINING PER D.RENAUD/D.SINISI

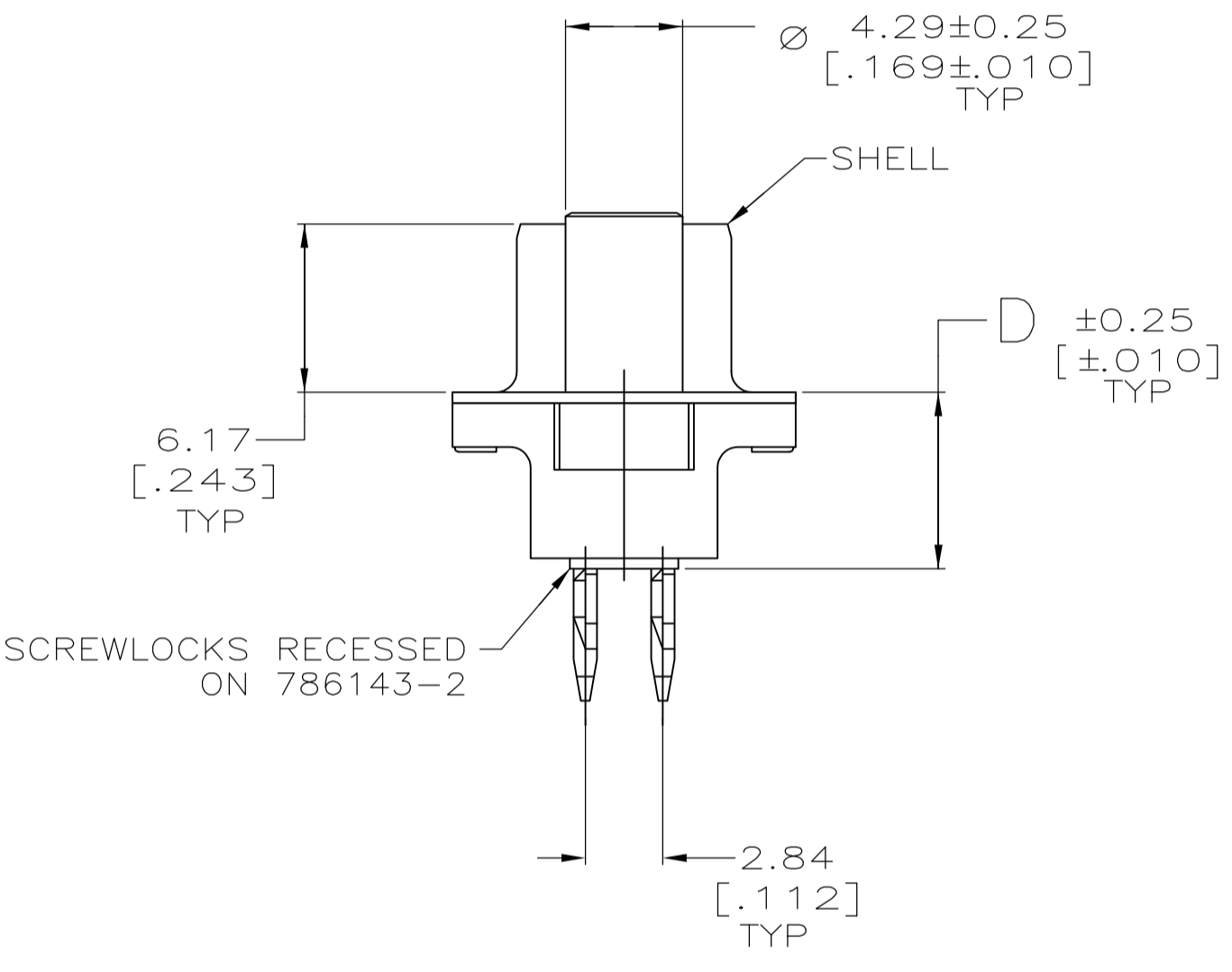
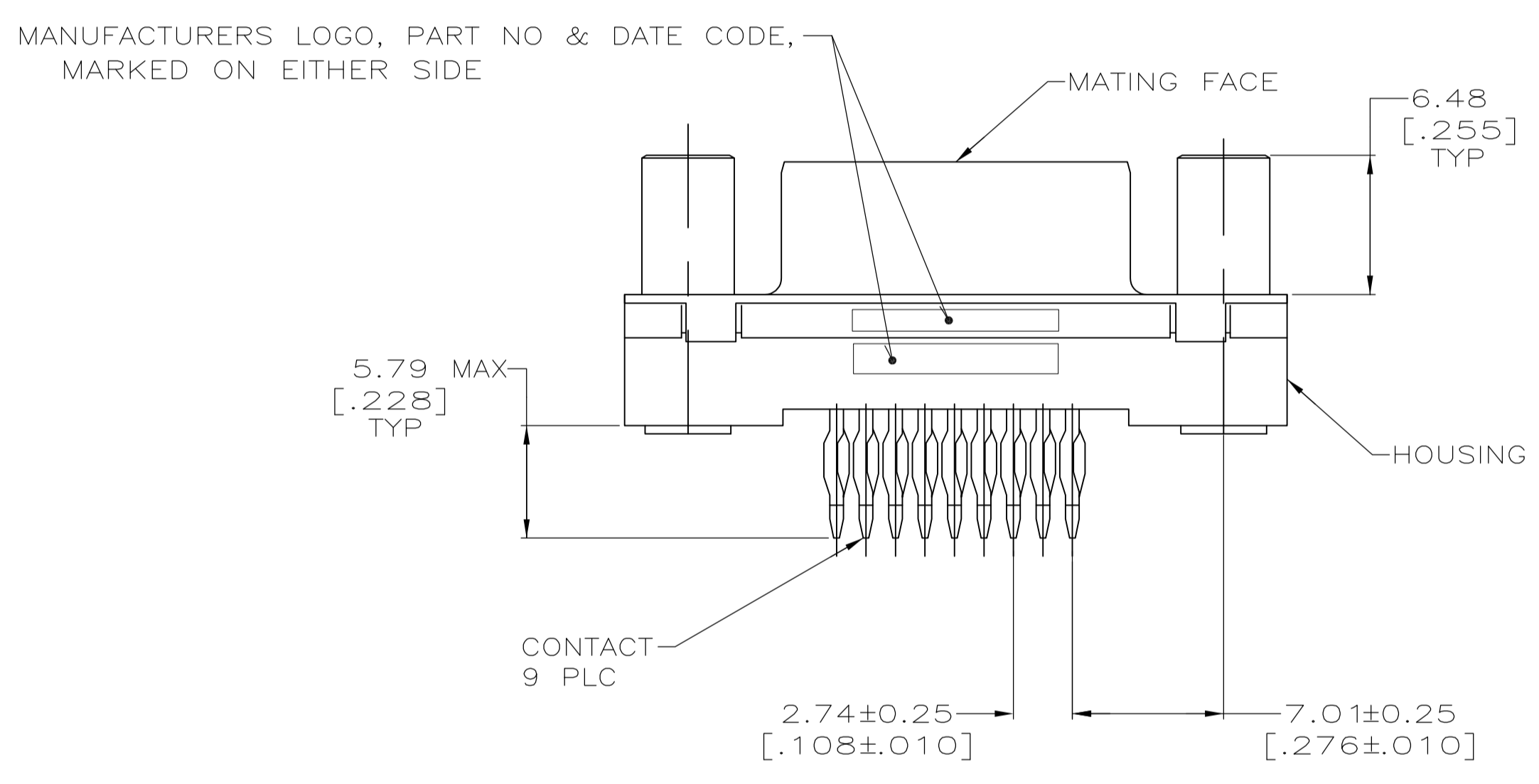

10	OBSOLETE	5.99 [.236]	-5786143-2
		6.48 [.255]	5786143-1
	D		PART NUMBER

**COPYRIGHT 2005  
 TYCO ELECTRONICS CORP  
 ALL RIGHTS RESERVED**

THIS DRAWING IS A CONTROLLED DOCUMENT. DIMENSIONING AND TOLERANCING PER ASME Y14.5M-2009		DIN J. ALCORTA - DOCK5 04-06-05		CIVIL S. BOLASH 04-06-05	
DIMENSIONS: INCHES		TOLERANCES UNLESS OTHERWISE SPECIFIED:		APVD M. WALMSLEY 04-06-05	
0 PLC ± -		1 PLC ± -		NAME RECEPTACLE ASSEMBLY, SIZE 1, 9 POSITION, ACTION PIN, VERTICAL, FRONT METAL SHELL AMPLIMITE HD-20	
2 PLC ± 0.13 [.005]		3 PLC ± -		PRODUCT SPEC 108-40014	
4 PLC ± -		ANGLES ± -		APPLICATION SPEC 114-40026 1	
MATERIAL		FINISH		SIZE CAGE CODE DRAWING NO RESTRICTED TO	
A1		C=5786143		A1 00779 C=5786143	
CUSTOMER DRAWING		SCALE 4:1		SHEET 1 OF 1 REV C	