



FHP3392 — Fixed-Gain, $\pm 5V$, Triple 2:1, High-Speed Video Multiplexer

Features

- 0.1dB gain flatness to 102MHz at $2V_{PP}$
- 9ns channel switching time
- $<0.02\%/0.03^\circ$ differential gain/phase error
- 750MHz large signal -3dB bandwidth
- 2,600V/ μs slew rate
- 60mA output current (easily drives two video loads)
- 70dB channel to channel isolation
- 25mA supply current
- 7mA supply current when disabled
- Fully specified at $\pm 5V$ supplies
- Lead-free TSSOP-24 package

Applications

- RGB video switchers and routers
- Multiple input HDTV switching
- Picture-in-picture video switch
- Multi-channel ADC Driver

Description

The FHP3392 (G=2) is a triple 2:1 analog multiplexer designed for high-speed video applications. The output amplifiers offer a fixed gain of 6dB and stellar large signal performance of 335MHz -3dB bandwidth and 80MHz 0.1dB bandwidth. The $2V_{PP}$ bandwidth performance and 1,600V/ μs slew rate exceed the requirements of high-definition television (HDTV) and other multimedia applications. The output amplifier provides ample output current to drive multiple video loads.

The FHP3392 may be operated with dual power supplies from $\pm 2.5V$ to $\pm 6V$.

The FHP3392 consumes only 25mA of supply current and offer disable capability. While disabled, it consumes only 7mA and the outputs become high impedance, allowing multiplexer expansion with multiple FHP3392s.

Ordering Information

Part Number	Pb-Free	Gain	Operating Temperature Range	Package	Packing Method
FHP3392IMTC24X	Yes	6dB	-40°C to +85°C	24-Lead, Thin Shrink Outline Package, JEDEC MO-153, 4.4mm Wide	Tape and Reel

Moisture sensitivity level for all parts is MSL-1.

Block Diagram and Pin Configuration

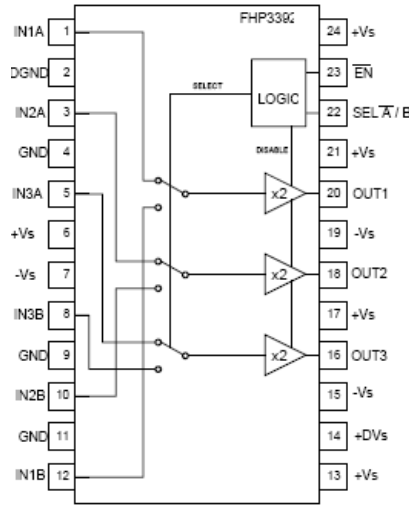

Figure 1. Block Diagram and Pin Configuration

Pin Definitions

Pin #	Name	Description
1	IN1A	1st Input Channel A
2	DGND	Digital Ground, must be connected to ground
3	IN2A	2nd Input Channel A
4	GND	Must be connected to ground
5	IN3A	3rd Input Channel A
6	+Vs	Positive supply
7	-Vs	Negative supply
8	IN3B	3rd Input Channel B
9	GND	Must be connected to ground
10	IN2B	2nd Input Channel B
11	GND	Must be connected to ground
12	IN1B	1st Input Channel B
13	+Vs	Positive supply
14	+DVs	Digital positive supply
15	-Vs	Negative supply
16	OUT3	3rd output
17	+Vs	Positive supply
18	OUT3	2nd output
19	-Vs	Negative supply
20	OUT1	1st Output
21	+Vs	Logic input; "0" = Channel A, "1" = Channel B
22	SEL A/B	Enable pin; "0" = Enable, "1" = Disable; Enabled if left floating or grounded
23	EN	Enable Pin: "0" = Channel A, "1" = Channel B
24	+Vs	Positive supply

Truth Table

SEL A/B	EN	OUT
0	0	Channel A
1	0	Channel B
X	1	Disable

Absolute Maximum Ratings

Stresses exceeding the absolute maximum ratings may damage the device. The device may not function or be operable above the recommended operating conditions and stressing the parts to these levels is not recommended. In addition, extended exposure to stresses above the recommended operating conditions may affect device reliability. The absolute maximum ratings are stress ratings only.

Symbol	Parameter	Min.	Max.	Unit
V_{CC}	Supply Voltage	0	13.3	V
V_{IN}	Input Voltage Range	$-V_S - 0.5$	$+V_S + 0.5V$	V

Electrostatic Discharge Protection

Symbol	Parameter	Min.	Max.	Unit
ESD	Human Body Model (HBM)		3	kV
	Charged Device Model (CDM)		12	kV

Reliability Information

Symbol	Parameter	Min.	Typ.	Max.	Unit
T_J	Junction Temperature			150	°C
T_{STG}	Storage Temperature	-65		150	°C
T_{RF}	Reflow Temperature			260	°C
θ_{JA}	Thermal Resistance		87		°C/W

Note:

1. Thermal Resistance (θ_{JA}) JEDEC standard, multi-layer test boards, in still air.

Recommended Operating Conditions

The Recommended Operating Conditions table defines the conditions for actual device operation. Recommended operating conditions are specified to ensure optimal performance to the datasheet specifications. Fairchild does not recommend exceeding them or designing to Absolute Maximum Ratings.

Symbol	Parameter	Min.	Typ.	Max.	Unit
T_A	Operating Temperature Range	-40		+85	°C
V_{CC}	Supply Voltage Range	±2.5	±5.0	±6.0	V

Electrical Characteristics at ±5V

T_A = 25°C, V_S = ± 5V, R_L = 150Ω; unless otherwise noted.

Symbol	Parameter	Conditions	Min.	Typ.	Max.	Units
Frequency Domain Response						
BW _{SS}	-3dB Bandwidth	V _{OUT} = 0.2V _{PP}		750		MHz
BW _{LS}	Large Signal Bandwidth	V _{OUT} = 2.0V _{PP}		560		MHz
BW _{0.1dBSS}	0.1dB Gain Flatness	V _{OUT} = 0.2V _{PP}		117		MHz
BW _{0.1dBLS}	0.1dB Gain Flatness	V _{OUT} = 2.0V _{PP}		102		MHz
Time Domain Response						
t _s	Settling Time to 0.1%	V _{OUT} = 2V step		4		ns
SR	Slew Rate	4V step		2600		V/μs
Distortion / Noise Response						
HD2	Second Harmonic Distortion	2V _{PP} , 5MHz		-85		dBc
HD3	Third Harmonic Distortion	2V _{PP} , 5MHz		-90		dBc
THD	Total Harmonic Distortion	2V _{PP} , 5MHz		-84		dB
		2V _{PP} , 22MHz		-72		dB
DG	Differential Gain	NTSC (3.58MHz)		0.04		%
DP	Differential Phase	NTSC (3.58MHz)		0.01		°
e _n	Input Voltage Noise	>1MHz		6.75		nV/Hz
i _n	Input Current Noise	>1MHz		22		pA/Hz
SNR	Signal-to-Noise Ratio	NTC-7 weighting, 4.2MHz LP filter, 100kHz PH filter		90		dB
X _{talk}	All Hostile Crosstalk	V _{OUT} = 2V _{PP} , ch-to-ch, 5MHz		-59		dB
		V _{OUT} = 2V _{PP} , ch-to-ch, 30MHz		-56		
DC Performance						
V _{OS}	Output Offset Voltage ⁽²⁾	V _{IN} = 0	-18	2	18	mV
I _b	Input Bias Current ⁽²⁾		-30	4	30	μA
G	Gain ⁽²⁾	DC	1.9	2.0	2.1	V/V
GM	Gain Matching	Channel-to-channel, DC		0.05		%
PSRR	Power Supply Rejection Ratio ⁽²⁾	DC, V _{CM} = 0, input referred, SEL = X	54	62		dB
I _S	Supply Current ⁽²⁾	No load, $\overline{EN} = 0$		25	30	mA
I _{EN}	Disable Supply Current ⁽²⁾	$\overline{EN} = 1$		7	10	mA
Switching Characteristics						
T _S	Switching Time 50% Logic to:	Channel-to channel				
	90% Output (10% Output Setting) ⁽³⁾	Ch A inputs = +0.5V Ch B inputs = -0.5V		17.3		ns
	99% Output (1% Output Setting) ⁽³⁾	Ch A inputs = +0.5V Ch B inputs = -0.5V		36		ns
V _{SW}	Channel Switching Transient (Glitch)	All inputs grounded		34		mV _{PP}

Notes:

- 100% tested at 25°.
- EN pin is grounded, channel A inputs = 0.5V, channel B inputs = -0.5V. Switching time is the transition time from 50% of SEL input value (+2.5V) to the time at which the switched channel is at 90% (or 99%) of its final value.

Electrical Characteristics at ±5V (Continued)

$T_A = 25^\circ\text{C}$, $V_S = \pm 5\text{V}$, $R_L = 150\Omega$; unless otherwise noted.

Symbol	Parameter	Conditions	Min.	Typ.	Max.	Units
Digital Inputs						
V_{IH}	Logic HIGH Threshold	SEL and \overline{EN} pins ⁽⁴⁾	2.0			V
V_{IL}	Logic LOW Threshold	SEL and \overline{EN} pins ⁽⁴⁾			0.8	V
I_{IH}	Logic Pin Input Current HIGH	SEL and \overline{EN} pins; Logic Input = 2V		27		μA
I_{IL}	Logic Pin Input Current LOW	SEL and \overline{EN} pins; Logic Input = 0V		0		μA
Disable Characteristics						
EN_{ISO}	Disable Isolation	5MHz, $V_{IN} = 1V_{PP}$, $\overline{EN} = 1$		-81		dB
		30MHz, $V_{IN} = 1V_{PP}$, $\overline{EN} = 1$		-66		dB
CH_{ISO}	Channel-to-Channel Isolation	5MHz		-71		dB
ENT_{ON}	Turn-on-Time (Disable to ON)	$V_{IN} = 0.5\text{V}$		30		ns
ENT_{OFF}	Turn-off-Time (ON to Disable)	$V_{IN} = 0.5\text{V}$		65		ns
Input Characteristics						
R_{IN}	Input Resistance			115		k Ω
C_{IN}	Input Capacitance			10		pF
V_{IN}	Input Voltage Range			± 2		V
Output Characteristics						
V_O	Output Voltage Swing	$R_L = 2k\Omega$		± 4		V
		$R_L = 150\Omega$ ⁽⁴⁾	± 3.2	± 3.7		V
I_{OUT}	Linear Output Current			± 95		mA
I_{SC}	Short Circuit Output Current	$V_O = \text{GND}$		± 100		mA
R_{OUT}	Output Resistance, Closed Loop	Enabled, $\overline{EN} = 1$, 100kHz		0.17		Ω
		Disabled, $\overline{EN} = 1$, 100kHz		675		Ω
C_{OUT}	Output Capacitance	Disabled, $\overline{EN} = 1$, 100kHz		2.7		pF

Note:

4. 100% tested at 25° .

Physical Dimensions

Dimensions are in millimeters unless otherwise noted.

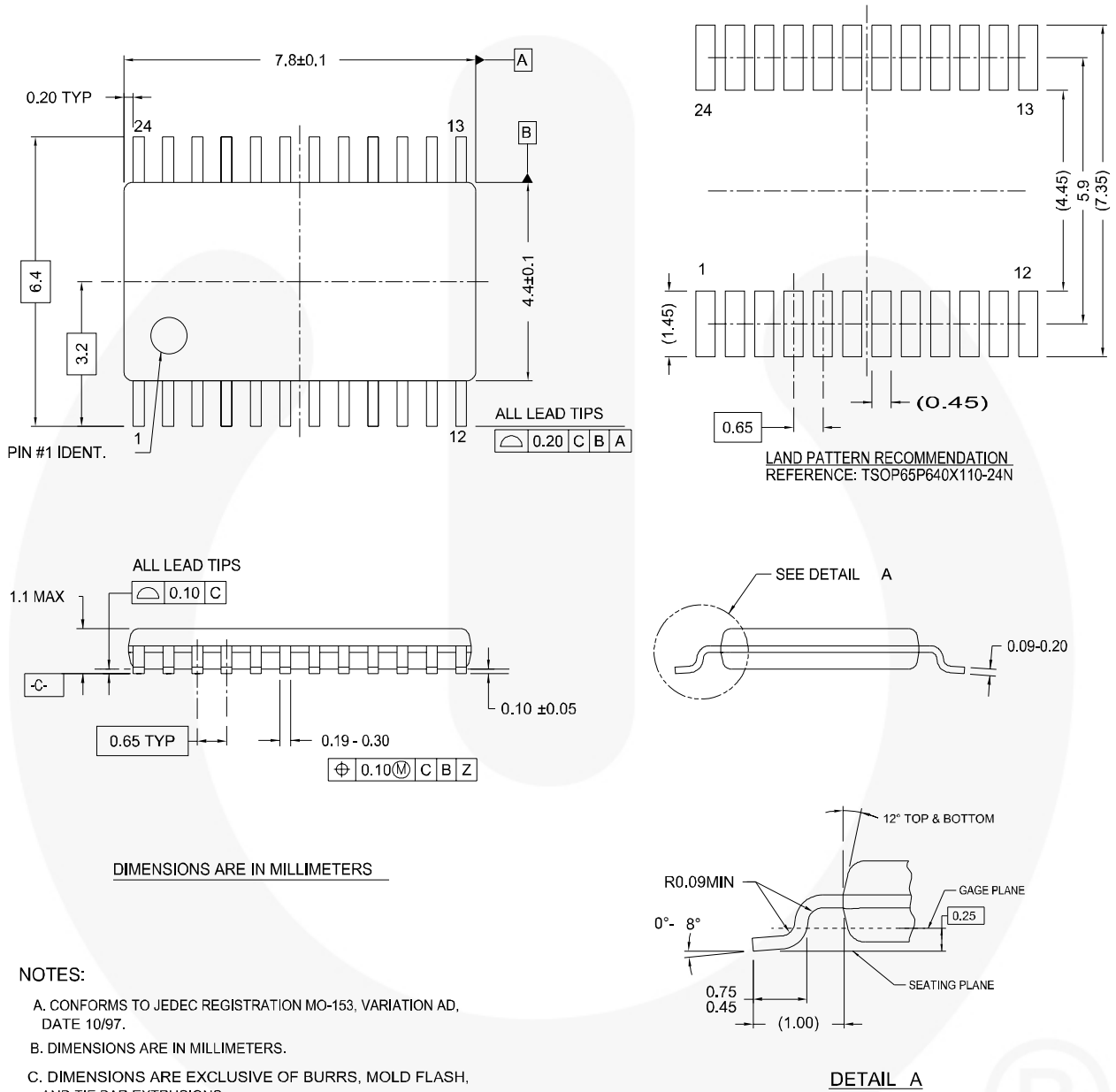

MTC24REV4

Figure 2. 24-Lead, Thin Shrink Outline Package, JEDEC MO-153, 4.4mm Wide



TRADEMARKS

The following are registered and unregistered trademarks and service marks Fairchild Semiconductor owns or is authorized to use and is not intended to be an exhaustive list of all such trademarks.

- | | | | |
|--------------------------------------|--|--|----------------------------------|
| ACEx [®] | Green FPS [™] | Power247 [®] | SuperSOT [™] -8 |
| Build it Now [™] | Green FPS [™] e-Series [™] | POWEREDGE [®] | SyncFET [™] |
| CorePLUS [™] | GTO [™] | Power-SPM [™] | The Power Franchise [®] |
| CROSSVOLT [™] | i-Lo [™] | PowerTrench [®] | the Power
franchise |
| CTL [™] | IntelliMAX [™] | Programmable Active Droop [™] | TinyBoost [™] |
| Current Transfer Logic [™] | ISOPLANAR [™] | QFET [®] | TinyBuck [™] |
| EcoSPARK [®] | MegaBuck [™] | QS [™] | TinyLogic [®] |
| F [®] | MICROCOUPLER [™] | QT Optoelectronics [™] | TINYOPTO [™] |
| Fairchild [®] | MicroFET [™] | Quiet Series [™] | RapidConfigure [™] |
| Fairchild Semiconductor [®] | MicroPak [™] | SMART START [™] | SPM [®] |
| FACT Quiet Series [™] | Motion-SPM [™] | STEALTH [™] | SuperFET [™] |
| FACT [®] | OPTOLOGIC [®] | SuperSOT [™] -3 | SuperSOT [™] -6 |
| FAST [®] | OPTOPLANAR [®] | UHC [®] | VCX [™] |
| FastVCore [™] | [®] | UniFET [™] | |
| FPS [™] | PDP-SPM [™] | | |
| FRFET [®] | Power220 [®] | | |
| Global Power Resource SM | | | |

DISCLAIMER

FAIRCHILD SEMICONDUCTOR RESERVES THE RIGHT TO MAKE CHANGES WITHOUT FURTHER NOTICE TO ANY PRODUCTS HEREIN TO IMPROVE RELIABILITY, FUNCTION, OR DESIGN. FAIRCHILD DOES NOT ASSUME ANY LIABILITY ARISING OUT OF THE APPLICATION OR USE OF ANY PRODUCT OR CIRCUIT DESCRIBED HEREIN; NEITHER DOES IT CONVEY ANY LICENSE UNDER ITS PATENT RIGHTS, NOR THE RIGHTS OF OTHERS. THESE SPECIFICATIONS DO NOT EXPAND THE TERMS OF FAIRCHILD'S WORLDWIDE TERMS AND CONDITIONS, SPECIFICALLY THE WARRANTY THEREIN, WHICH COVERS THESE PRODUCTS.

LIFE SUPPORT POLICY

FAIRCHILD'S PRODUCTS ARE NOT AUTHORIZED FOR USE AS CRITICAL COMPONENTS IN LIFE SUPPORT DEVICES OR SYSTEMS WITHOUT THE EXPRESS WRITTEN APPROVAL OF FAIRCHILD SEMICONDUCTOR CORPORATION.

As used herein:

1. Life support devices or systems are devices or systems which, (a) are intended for surgical implant into the body, or (b) support or sustain life, and (c) whose failure to perform when properly used in accordance with instructions for use provided in the labeling, can be reasonably expected to result in significant injury to the user.
2. A critical component is any component of a life support device or system whose failure to perform can be reasonably expected to cause the failure of the life support device or system, or to affect its safety or effectiveness.

PRODUCT STATUS DEFINITIONS

Definition of Terms

Datasheet Identification	Product Status	Definition
Advance Information	Formative or In Design	This datasheet contains the design specifications for product development. Specifications may change in any manner without notice.
Preliminary	First Production	This datasheet contains preliminary data; supplementary data will be published at a later date. Fairchild Semiconductor reserves the right to make changes at any time without notice to improve design.
No Identification Needed	Full Production	This datasheet contains final specifications. Fairchild Semiconductor reserves the right to make changes at any time without notice to improve design.
Obsolete	Not In Production	This datasheet contains specifications on a product that has been discontinued by Fairchild semiconductor. The datasheet is printed for reference information only.

Rev. 130