

FEATURES

- Triaxial digital gyroscope with digital range scaling**
 $\pm 75^\circ/\text{sec}$, $\pm 150^\circ/\text{sec}$, $\pm 300^\circ/\text{sec}$ settings
Tight orthogonal alignment: $<0.05^\circ$
- Triaxial digital accelerometer: $\pm 5 g$**
- Wide sensor bandwidth: 330 Hz**
- Autonomous operation and data collection**
No external configuration commands required
Start-up time: 180 ms
- Factory-calibrated sensitivity, bias, and axial alignment**
Calibration temperature range: -20°C to $+70^\circ\text{C}$
- SPI-compatible serial interface**
- Embedded temperature sensor**
- Programmable operation and control**
Automatic and manual bias correction controls
Bartlett window FIR filter length, number of taps
Digital I/O: data ready, alarm indicator, general-purpose
Alarms for condition monitoring
Enable external sample clock input: up to 1.2 kHz
Single-command self-test
- Single-supply operation: 4.75 V to 5.25 V**
- 2000 g shock survivability**
- 24 mm \times 33 mm \times 11 mm module with connector interface**
- Operating temperature range: -40°C to $+105^\circ\text{C}$**

APPLICATIONS

- Medical instrumentation
- Robotics
- Platform controls
- Navigation

GENERAL DESCRIPTION

The ADIS16334 *iSensor*® is a complete inertial system that includes a triaxial gyroscope and triaxial accelerometer. Each sensor in the ADIS16334 combines *iMEMS*® technology with signal conditioning that optimizes dynamic performance. The factory calibration characterizes each sensor for sensitivity, bias, alignment, and linear acceleration (gyro bias). As a result, each sensor has its own dynamic compensation formulas that provide accurate sensor measurements over a temperature range of -20°C to $+70^\circ\text{C}$.

The ADIS16334 provides a simple, cost-effective method for integrating accurate, multi-axis, inertial sensing into industrial systems, especially when compared with the complexity and investment associated with discrete designs. All necessary motion testing and calibration are part of the production process at the factory, greatly reducing system integration time. Tight orthogonal alignment simplifies inertial frame alignment in navigation systems. An improved serial peripheral interface (SPI) interface and register structure provide faster data collection and configuration control.

This compact module is approximately 24 mm \times 33 mm \times 11 mm and provides a compact connector interface.

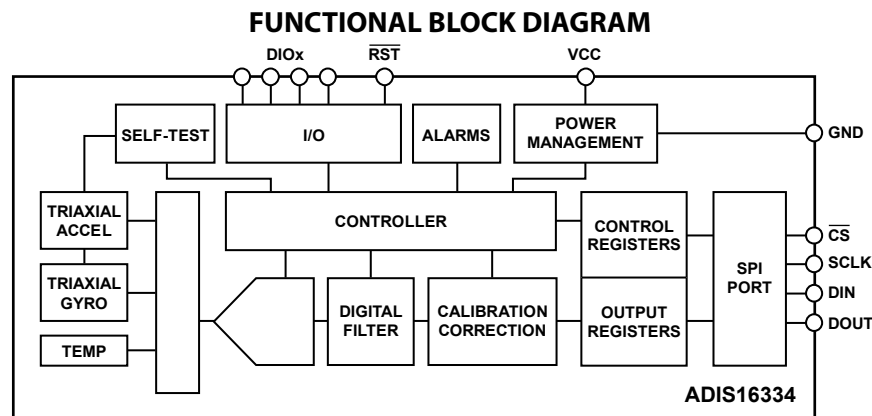

Figure 1.

Rev. D

[Document Feedback](#)

Information furnished by Analog Devices is believed to be accurate and reliable. However, no responsibility is assumed by Analog Devices for its use, nor for any infringements of patents or other rights of third parties that may result from its use. Specifications subject to change without notice. No license is granted by implication or otherwise under any patent or patent rights of Analog Devices. Trademarks and registered trademarks are the property of their respective owners.

One Technology Way, P.O. Box 9106, Norwood, MA 02062-9106, U.S.A.
 Tel: 781.329.4700 ©2011–2019 Analog Devices, Inc. All rights reserved.
[Technical Support](#) www.analog.com

TABLE OF CONTENTS

Features	1	Digital Filtering.....	14
Applications.....	1	Dynamic Range	14
General Description	1	Optimizing Accuracy.....	15
Functional Block Diagram	1	Automatic Bias Correction	15
Revision History	2	Manual Bias Correction	15
Specifications.....	3	Restoring Factory Calibration	15
Timing Specifications	5	Point-of-Percussion/Linear-g Compensation	15
Timing Diagrams.....	5	System Tools.....	16
Absolute Maximum Ratings.....	6	Global Commands	16
ESD Caution.....	6	Device Identification.....	17
Pin Configuration and Function Descriptions.....	7	Flash Memory Management	17
Typical Performance Characteristics	8	Alarms.....	18
Theory of Operation	9	Static Alarm Use	18
Gyroscopes	9	Dynamic Alarm Use	18
Accelerometers.....	9	Alarm Reporting	18
Data Sampling and Processing	9	Applications Information	19
Calibration.....	9	Mounting Tips	19
User Interface.....	9	Power Supply Considerations.....	19
Basic Operation.....	10	Breakout Boards	19
Reading Sensor Data.....	10	Evaluation System	19
Memory Map	11	ADIS16IMU2/PCBZ.....	19
Output Data Registers.....	12	PC-Based Evaluation Tools.....	19
Device Configuration	13	X-Ray Sensitivity	19
Digital Processing Configuration.....	14	Outline Dimensions	20
Sample Rate	14	Ordering Guide	20
Input Clock Configuration.....	14		

REVISION HISTORY

4/2019—Rev. C to Rev. D

Added Endnote 1, Table 1; Renumbered Sequentially	4
Change to ADIS16IMU2/PCBZ Section	19
Added X-Ray Sensitivity Section.....	19
Changes to Ordering Guide	20

5/2018—Rev. B to Rev. C

Deleted Figure 23 and Figure 24; Renumbered Sequentially ...	19
Deleted Installation Section and Mounting Approaches Section.....	19
Added Mounting Tips Section, Power Supply Considerations Section, Breakout Boards Section, Evaluation System Section, Figure 23, PC-Based Evaluation Tools Section, and Figure 24; Renumbered Sequentially.....	19
Changes to ADIS16IMU2/PCBZ Section	19
Changes to Ordering Guide	20

5/2013—Rev. A to Rev. B

Changes to Features and General Description Section	1
Deleted V_{IL} (\overline{CS} Signal to Wake Up from Sleep Mode) of 0.55 V and \overline{CS} Wake-Up Pulse Width of 20 μ s; Table 1.....	4
Changed t_{STALL} Burst Read Min from $1/f_{CLK}$ to N/A; Added $t_{READRATE}$ Burst Read Min of N/A; Table 2	5
Added Mounting Approaches Section	19

6/2011—Rev. 0 to Rev. A

Changes to In-Run Bias Stability Parameter, Table 1	3
Changes to Figure 23.....	19

1/2011—Revision 0: Initial Version

SPECIFICATIONS

$T_A = 25^\circ\text{C}$, $V_{CC} = 5.0\text{ V}$, angular rate = $0^\circ/\text{sec}$, dynamic range = $\pm 300^\circ/\text{sec} \pm 1\text{ g}$, unless otherwise noted.

Table 1.

Parameter	Test Conditions/Comments	Min	Typ	Max	Unit
GYROSCOPES					
Dynamic Range		± 300	± 350		$^\circ/\text{sec}$
Initial Sensitivity	Dynamic range = $\pm 300^\circ/\text{sec}$	0.0495	0.05	0.0505	$^\circ/\text{sec}/\text{LSB}$
	Dynamic range = $\pm 150^\circ/\text{sec}$		0.025		$^\circ/\text{sec}/\text{LSB}$
	Dynamic range = $\pm 75^\circ/\text{sec}$		0.0125		$^\circ/\text{sec}/\text{LSB}$
Sensitivity Temperature Coefficient	$-20^\circ\text{C} \leq T_A \leq +70^\circ\text{C}$		± 40		$\text{ppm}/^\circ\text{C}$
Nonlinearity	Best-fit straight line		± 0.1		% of FS
Misalignment	Axis to axis		± 0.05		Degrees
	Axis-to-frame (package)		± 0.5		Degrees
Initial Bias Error	$\pm 1\sigma$		± 3		$^\circ/\text{sec}$
In-Run Bias Stability	1σ , $\text{SMPL_PRD} = 0x0001$		0.0072		$^\circ/\text{sec}$
Angular Random Walk	1σ , $\text{SMPL_PRD} = 0x0001$		2		$^\circ/\sqrt{\text{hr}}$
Bias Temperature Coefficient	$-20^\circ\text{C} \leq T_A \leq +70^\circ\text{C}$		± 0.005		$^\circ/\text{sec}/^\circ\text{C}$
Linear Acceleration Effect on Bias	Any axis, 1σ ($\text{MSC_CTRL}[7] = 1$)		± 0.05		$^\circ/\text{sec}/\text{g}$
Bias Voltage Sensitivity	$V_{CC} = 4.75\text{ V}$ to 5.25 V		± 0.3		$^\circ/\text{sec}/\text{V}$
Output Noise	$\pm 300^\circ/\text{sec}$ range, no filtering		0.75		$^\circ/\text{sec rms}$
Rate Noise Density	$f = 25\text{ Hz}$, $\pm 300^\circ/\text{sec}$ range, no filtering		0.044		$^\circ/\text{sec}/\sqrt{\text{Hz rms}}$
3 dB Bandwidth			330		Hz
Sensor Resonant Frequency			14.5		kHz
ACCELEROMETERS					
	Each axis				
Dynamic Range		± 5	± 5.25		g
Initial Sensitivity		0.99	1.00	1.01	mg/LSB
Sensitivity Temperature Coefficient	$-20^\circ\text{C} \leq T_A \leq +70^\circ\text{C}$		± 40		$\text{ppm}/^\circ\text{C}$
Misalignment	Axis-to-axis		± 0.1		Degrees
	Axis-to-frame (package)		± 0.5		Degrees
Nonlinearity	Best-fit straight line		± 0.1		% of FS
Initial Bias Error ¹	$\pm 1\sigma$		± 12		mg
In-Run Bias Stability	1σ		100		μg
Velocity Random Walk	1σ		0.11		$\text{m}/\text{sec}/\sqrt{\text{hr}}$
Bias Temperature Coefficient	$-20^\circ\text{C} \leq T_A \leq +70^\circ\text{C}$		± 0.06		$\text{mg}/^\circ\text{C}$
Bias Voltage Sensitivity	$V_{CC} = 4.75\text{ V}$ to 5.25 V		± 5		mg/V
Output Noise	No filtering		4		mg rms
Noise Density	No filtering		221		$\mu\text{g}/\sqrt{\text{Hz rms}}$
3 dB Bandwidth			330		Hz
Sensor Resonant Frequency			5.5		kHz
TEMPERATURE SENSOR					
Scale Factor	Output = $0x0000$ at 25°C ($\pm 5^\circ\text{C}$)		0.0678		$^\circ\text{C}/\text{LSB}$
LOGIC INPUTS²					
Input High Voltage, V_{IH}		2.0			V
Input Low Voltage, V_{IL}				0.8	V
Logic 1 Input Current, I_{IH}	$V_{IH} = 3.3\text{ V}$		± 0.2	± 10	μA
Logic 0 Input Current, I_{IL}	$V_{IL} = 0\text{ V}$				μA
All Pins Except $\overline{\text{RST}}$			40	60	μA
$\overline{\text{RST}}$ Pin			1		mA
Input Capacitance, C_{IN}			10		pF
DIGITAL OUTPUTS²					
Output High Voltage, V_{OH}	$I_{SOURCE} = 1.6\text{ mA}$	2.4			V
Output Low Voltage, V_{OL}	$I_{SINK} = 1.6\text{ mA}$			0.4	V

Parameter	Test Conditions/Comments	Min	Typ	Max	Unit
FLASH MEMORY Data Retention ⁴	Endurance ³ T _j = 85°C	10,000 20			Cycles Years
FUNCTIONAL TIMES ⁵	Time until data is available				
Power-On Start-Up Time	Normal mode		180		ms
Reset Recovery Time	Normal mode		60		ms
Flash Memory Test Time	Normal mode		20		ms
Self-Test Time	SMPL_PRD = 0x0001		14		ms
CONVERSION RATE					
Internal Sample Rate	SMPL_PRD = 0x0001		819.2		SPS
Tolerance				±3	%
Sync Input Clock ⁶	SMPL_PRD = 0x0000	0.8		1.2	kHz
POWER SUPPLY					
Supply Voltage		4.75	5.0	5.25	V
Power Supply Current			47		mA

¹ X-ray exposure may degrade this performance metric.

² The digital I/O signals are driven by an internal 3.3 V supply, and the inputs are 5 V tolerant.

³ Endurance is qualified as per JEDEC Standard 22, Method A117, and measured at -40°C, +25°C, +85°C, and +125°C.

⁴ The data retention lifetime equivalent is at a junction temperature (T_j) of 85°C as per JEDEC Standard 22, Method A117. Data retention lifetime decreases with junction temperature.

⁵ These times do not include thermal settling and internal filter response times (330 Hz bandwidth), which may affect overall accuracy.

⁶ The sync input clock functions below the specified minimum value, at reduced performance levels.

TIMING SPECIFICATIONS

T_A = 25°C, VCC = 5.0 V, unless otherwise noted.

Table 2.

Parameter	Description	Normal Read			Burst Read			Unit
		Min ¹	Typ	Max	Min ¹	Typ	Max	
f _{SCLK}	Serial clock	0.01		2.0	0.01		1.0	MHz
t _{STALL}	Stall period between data	9			N/A ²			μs
t _{READRATE}	Read rate	40			N/A ²			μs
t _{CS}	Chip select to SCLK edge	48.8			48.8			ns
t _{DAV}	DOUT valid after SCLK edge			100			100	ns
t _{DSU}	DIN setup time before SCLK rising edge	24.4			24.4			ns
t _{DHD}	DIN hold time after SCLK rising edge	48.8			48.8			ns
t _{SCLKR} , t _{SCLKF}	SCLK rise/fall times		5	12.5		5	12.5	ns
t _{DR} , t _{DF}	DOUT rise/fall times		5	12.5		5	12.5	ns
t _{SFS}	CS high after SCLK edge	5			5			ns
t ₁	Input sync positive pulse width	5			5			μs
t _x	Input sync low time	100			100			μs
t ₂	Input sync to data ready output		600			600		μs
t ₃	Input sync period	833			833			μs

¹ Guaranteed by design and characterization, but not tested in production.

² Does not apply to burst read.

TIMING DIAGRAMS

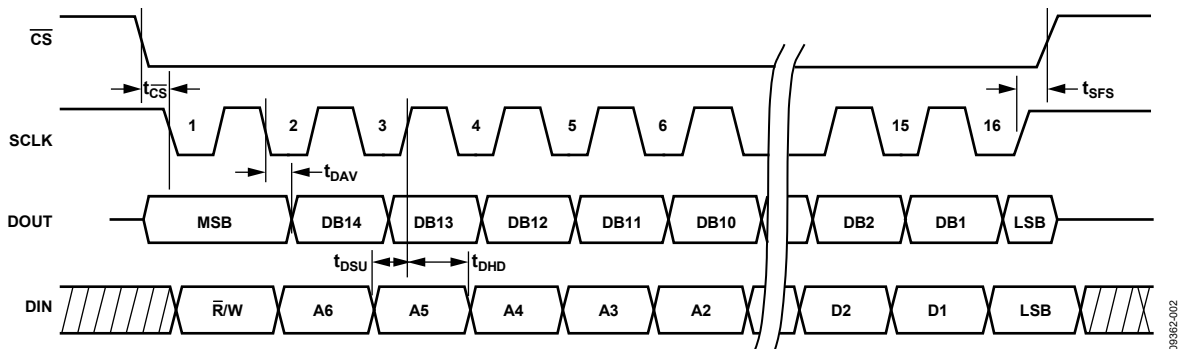

Figure 2. SPI Timing and Sequence

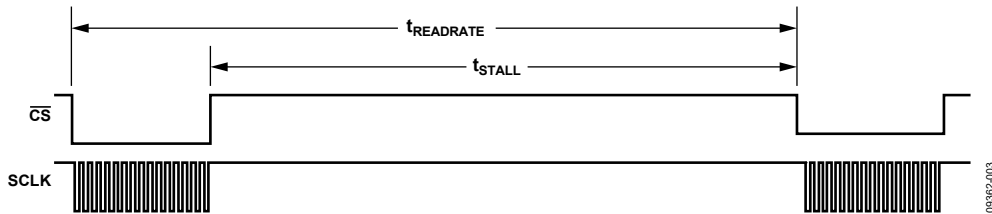

Figure 3. Stall Time and Data Rate

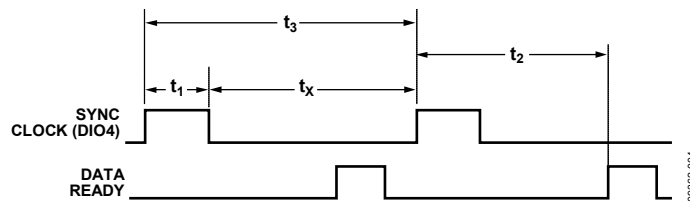

Figure 4. Input Clock Timing Diagram

ABSOLUTE MAXIMUM RATINGS

Table 3.

Parameter	Rating
Acceleration	
Any Axis, Unpowered	2000 g
Any Axis, Powered	2000 g
VCC to GND	−0.3 V to +6.0 V
Digital Input Voltage to GND	−0.3 V to +5.3 V
Digital Output Voltage to GND	−0.3 V to VCC + 0.3 V
Analog Input to GND	−0.3 V to +3.6 V
Operating Temperature Range	−40°C to +105°C
Storage Temperature Range	−65°C to +125°C ^{1,2}

¹ Extended exposure to temperatures outside the specified temperature range of −40°C to +105°C can adversely affect the accuracy of the factory calibration. For best accuracy, store the parts within the specified operating range of −40°C to +105°C.

² Although the device is capable of withstanding short-term exposure to 150°C, long-term exposure threatens internal mechanical integrity.

Stresses at or above those listed under Absolute Maximum Ratings may cause permanent damage to the product. This is a stress rating only; functional operation of the product at these or any other conditions above those indicated in the operational section of this specification is not implied. Operation beyond the maximum operating conditions for extended periods may affect product reliability.

Table 4. Package Characteristics

Package Type	θ_{JA}	θ_{JC}	Device Weight
20-Lead Module (ML-20-1)	36.5°C	16.9°C	12.5 grams

ESD CAUTION



ESD (electrostatic discharge) sensitive device. Charged devices and circuit boards can discharge without detection. Although this product features patented or proprietary protection circuitry, damage may occur on devices subjected to high energy ESD. Therefore, proper ESD precautions should be taken to avoid performance degradation or loss of functionality.

PIN CONFIGURATION AND FUNCTION DESCRIPTIONS

ADIS16334
TOP VIEW
(Not to Scale)

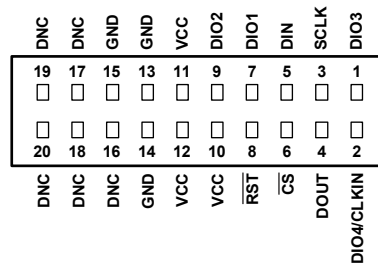

- NOTES**
1. THIS REPRESENTATION DISPLAYS THE TOP VIEW WHEN THE CONNECTOR IS VISIBLE AND FACING UP.
 2. MATING CONNECTOR: SAMTEC CLM-110-02 OR EQUIVALENT.
 3. DNC = DO NOT CONNECT.

09382-005

Figure 5. Pin Configuration

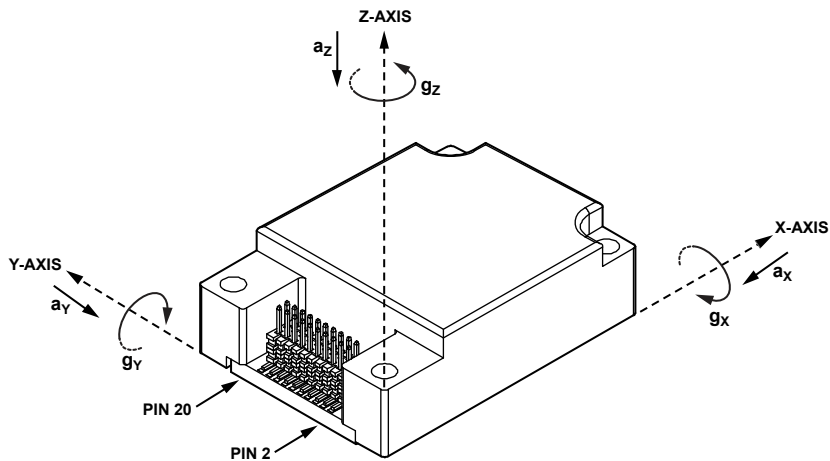

- NOTES**
1. ACCELERATION (a_x , a_y , a_z) AND ROTATIONAL (g_x , g_y , g_z) ARROWS INDICATE THE DIRECTION OF MOTION THAT PRODUCES A POSITIVE OUTPUT.

09382-006

Figure 6. Axial Orientation

Table 5. Pin Function Descriptions

Pin No.	Mnemonic	Type ¹	Description
1	DIO3	I/O	Configurable Digital Input/Output.
2	DIO4/CLKIN	I/O	Configurable Digital Input/Output or Sync Clock Input.
3	SCLK	I	SPI Serial Clock.
4	DOUT	O	SPI Data Output. Clocks output on SCLK falling edge.
5	DIN	I	SPI Data Input. Clocks input on SCLK rising edge.
6	CS	I	SPI Chip Select.
7, 9	DIO1, DIO2	I/O	Configurable Digital Input/Output.
8	RST	I	Reset.
10, 11, 12	VCC	S	Power Supply.
13, 14, 15	GND	S	Power Ground.
16, 17, 18, 19, 20	DNC	N/A	Do Not Connect.

¹ I/O is input/output, I is input, O is output, S is supply, and N/A is not applicable.

TYPICAL PERFORMANCE CHARACTERISTICS

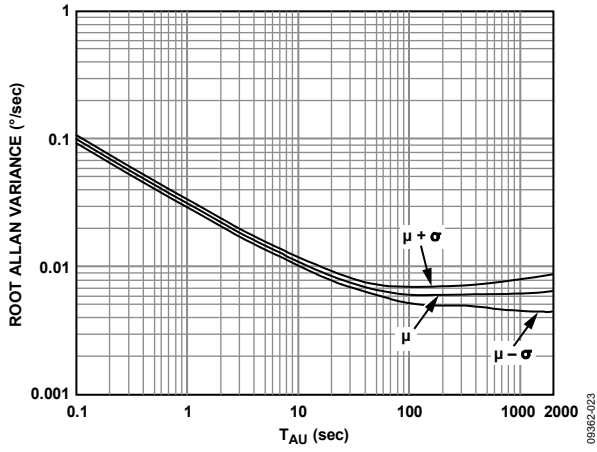

Figure 7. Gyroscope Allan Variance

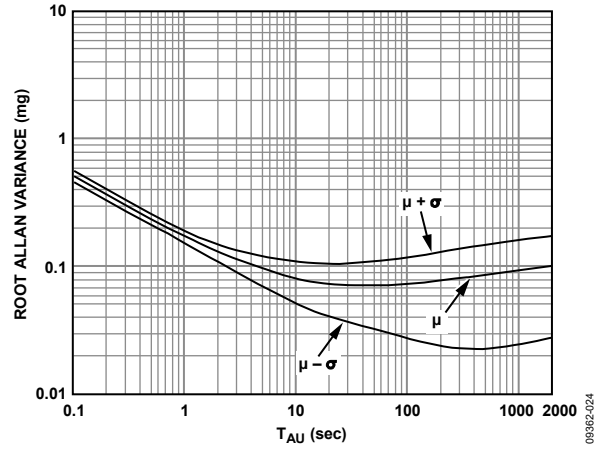

Figure 8. Accelerometer Allan Variance

THEORY OF OPERATION

The ADIS16334 is a six degree of freedom (6DOF) inertial sensing system. This sensing system collects data autonomously and makes it available to any processor system that supports a 4-wire serial peripheral interface (SPI).

GYROSCOPES

Angular rate sensing in the ADIS16334 begins with a MEMS gyroscope that operates on the principle of a resonator gyro. Two polysilicon sensing structures each contain a dither frame that is electrostatically driven to resonance, producing the necessary velocity element to produce a Coriolis force during angular rate. At two of the outer extremes of each frame, orthogonal to the dither motion, are movable fingers that are placed between fixed pickoff fingers to form a capacitive pickoff structure that senses Coriolis motion. The resulting signal is fed to a series of gain and demodulation stages that produce the electrical rate signal output. The dual-sensor design rejects external g -forces and vibration.

ACCELEROMETERS

Acceleration sensing in the ADIS16334 starts with a MEMS accelerometer core on each axis, which provides a linear motion-to-electrical transducer function. Tiny polysilicon springs tether a movable structure to a fixed frame inside the sensor core. The springs and mass of the movable structure provide a dependable relationship between acceleration and physical displacement between them. The moving structure and fixed frame have electrical plates in a balanced, differential capacitor network. When experiencing dynamic or static acceleration, it causes a physical deflection, which causes an imbalance in the capacitive network. A modulation/demodulation circuit translates the capacitor imbalance into a representative electrical signal.

DATA SAMPLING AND PROCESSING

The analog signals from each inertial sensor feed into a mixed signal processing circuit, which includes buffering, analog filtering, digital sampling, digital filtering, and calibration.

CALIBRATION

The digital processing stage includes a correction function for each accelerometer and gyroscope sensor. Each sensor within each unit has unique correction formulas, which optimize their bias and sensitivity accuracy over temperature and supply. The full, 6DOF characterization also enables an internal frame alignment, which minimizes cross-axis sensitivity and simplifies frame alignment after system installation.

USER INTERFACE

SPI Interface

The user registers manage user access to both sensor data and configuration inputs. Each 16-bit register has its own unique bit assignment and two addresses: one for its upper byte and one for its lower byte. Table 8 provides a memory map for each register, along with its function and lower byte address. Each data collection and configuration command both use the SPI, which consists of four wires. The chip select (\overline{CS}) signal activates the SPI interface and the serial clock (SCLK) synchronizes the serial data lines. Input commands clock into the DIN pin, one bit at a time, on the SCLK rising edge. Output data clocks out of the DOUT pin on the SCLK falling edge. As a SPI slave device, the DOUT contents reflect the information requested using a DIN command.

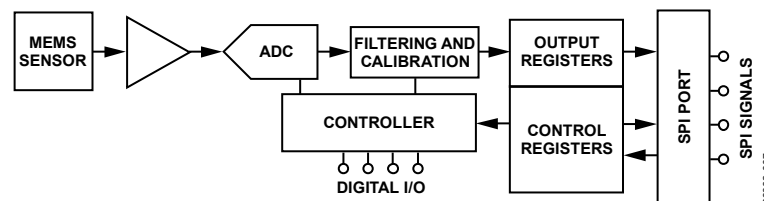

Figure 9. Simplified Sensor Signal Processing Diagram

BASIC OPERATION

The ADIS16334 is an autonomous system that requires no user initialization. When it has a valid power supply, it initializes itself and starts sampling, processing, and loading sensor data into the output registers at a sample rate of 819.2 SPS. DIO1 pulses high after each sample cycle concludes. The SPI interface enables simple integration with many embedded processor platforms, as shown in Figure 10 (electrical connection) and Table 6 (pin descriptions).

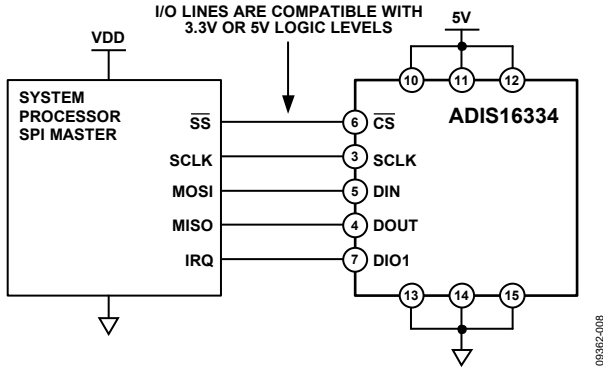

Figure 10. Electrical Connection Diagram

Table 6. Generic Master Processor Pin Names and Functions

Pin Name	Function
SS	Slave select
SCLK	Serial clock
MOSI	Master output, slave input
MISO	Master input, slave output
IRQ	Interrupt request

The ADIS16334 SPI interface supports full-duplex serial communication (simultaneous transmit and receive) and uses the bit sequence shown in Figure 14. Table 7 provides a list of the most common settings that require attention to initialize a processor's serial port for the ADIS16334 SPI interface.

Table 7. Generic Master Processor SPI Settings

Processor Setting	Description
Master	The ADIS16334 operates as a slave.
SCLK Rate ≤ 2 MHz ¹	Maximum serial clock rate.
SPI Mode 3	CPOL = 1 (polarity), CPHA = 1 (phase).
MSB First Mode	Bit sequence.
16-Bit Mode	Shift register/data length.

¹ For burst read, SCLK rate ≤ 1 MHz.

READING SENSOR DATA

The ADIS16334 provides two different options for acquiring sensor data: single register and burst register. A single register read requires two 16-bit SPI cycles. The first cycle requests the contents of a register using the bit assignments in Figure 14. Bit DC7 to Bit DC0 are don't cares for a read, and then the output register contents follow on DOUT during the second sequence. Figure 11 includes three single register reads in succession. In this example, the process starts with DIN = 0x0400 to request the contents of XGYRO_OUT, then follows with 0x0600 to request YGYRO_OUT and 0x0800 to request ZGYRO_OUT. Full-duplex operation enables processors to use the same 16-bit SPI cycle to read data from DOUT while requesting the next set of data on DIN. Figure 12 provides an example of the four SPI signals when reading XGYRO_OUT in a repeating pattern.

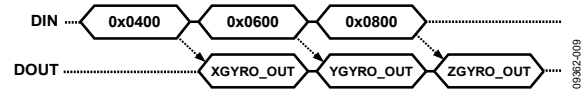

Figure 11. SPI Read Example

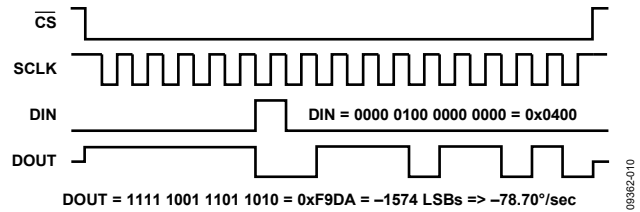

Figure 12. Example SPI Read, Second 16-Bit Sequence

Burst Read Function

The burst read function enables the user to read all output registers using one command on the DIN line and shortens the stall time between each 16-bit segment to one SCLK cycle (see Table 2). Figure 13 provides the burst read sequence of data on each SPI signal. The sequence starts with writing 0x3E00 to DIN, followed by each output register clocking out on DOUT, in the order in which they appear in Table 8.

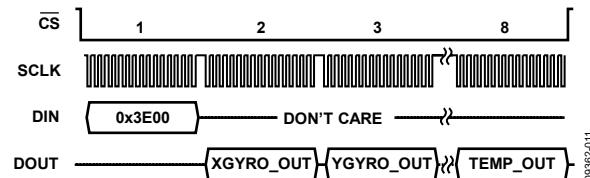
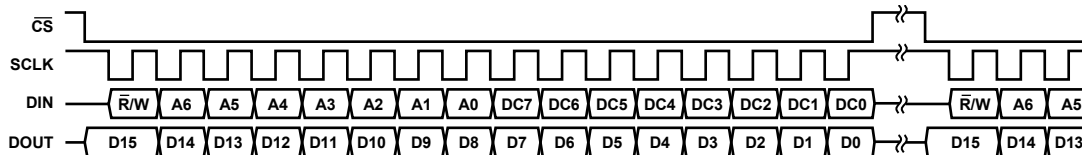

Figure 13. Burst Read Sequence



NOTES

- THE DOUT BIT PATTERN REFLECTS THE ENTIRE CONTENTS OF THE REGISTER IDENTIFIED BY [A6:A0] IN THE PREVIOUS 16-BIT DIN SEQUENCE WHEN R/W = 0.
- IF R/W = 1 DURING THE PREVIOUS SEQUENCE, DOUT IS NOT DEFINED.

Figure 14. SPI Communication Bit Sequence

MEMORY MAP

Table 8. User Register Memory Map

Name	User Access ¹	Flash Backup ¹	Address ^{1, 2}	Default ¹	Register Description	Bit Function ¹
FLASH_CNT	Read only	Yes	0x00	N/A	Flash memory write count	Table 30
Reserved	N/A	N/A	0x02	N/A	Reserved	N/A
XGYRO_OUT	Read only	No	0x04	N/A	Output, x-axis gyroscope	Table 10
YGYRO_OUT	Read only	No	0x06	N/A	Output, y-axis gyroscope	Table 10
ZGYRO_OUT	Read only	No	0x08	N/A	Output, z-axis gyroscope	Table 10
XACCL_OUT	Read only	No	0x0A	N/A	Output, x-axis accelerometer	Table 12
YACCL_OUT	Read only	No	0x0C	N/A	Output, y-axis accelerometer	Table 12
ZACCL_OUT	Read only	No	0x0E	N/A	Output, z-axis accelerometer	Table 12
TEMP_OUT	Read only	No	0x10	N/A	Output, internal temperature	Table 14
Reserved	N/A	N/A	0x12	N/A	Reserved	N/A
Reserved	N/A	N/A	0x14	N/A	Reserved	N/A
Reserved	N/A	N/A	0x16	N/A	Reserved	N/A
Reserved	N/A	N/A	0x18	N/A	Reserved	N/A
XGYRO_OFF	Read/write	Yes	0x1A	0x0000	Bias correction, x-axis gyroscope	Table 20
YGYRO_OFF	Read/write	Yes	0x1C	0x0000	Bias correction, y-axis gyroscope	Table 20
ZGYRO_OFF	Read/write	Yes	0x1E	0x0000	Bias correction, z-axis gyroscope	Table 20
XACCL_OFF	Read/write	Yes	0x20	0x0000	Bias correction, x-axis accelerometer	Table 21
YACCL_OFF	Read/write	Yes	0x22	0x0000	Bias correction, y-axis accelerometer	Table 21
ZACCL_OFF	Read/write	Yes	0x24	0x0000	Bias correction, z-axis accelerometer	Table 21
ALM_MAG1	Read/write	Yes	0x26	0x0000	Alarm 1, trigger polarity, threshold	Table 32
ALM_MAG2	Read/write	Yes	0x28	0x0000	Alarm 2, trigger polarity, threshold	Table 33
ALM_SMPL1	Read/write	Yes	0x2A	0x0000	Alarm 1, sample size	Table 34
ALM_SMPL2	Read/write	Yes	0x2C	0x0000	Alarm 2, sample size	Table 34
ALM_CTRL	Read/write	Yes	0x2E	0x0000	Alarm, control	Table 35
Reserved	N/A	N/A	0x30	N/A	Reserved	N/A
GPIO_CTRL	Read/write	No	0x32	0x0000	System, DIOx configuration and control	Table 24
MSC_CTRL	Read/write	Yes	0x34	0x0006	System, data ready, self-test, calibration	Table 25
SMPL_PRD	Read/write	Yes	0x36	0x0001	Sample rate, decimation control	Table 17
SENS_AVG	Read/write	Yes	0x38	0x0402	Dynamic range, digital filter control	Table 18
Reserved	N/A	N/A	0x3A	N/A	Reserved	N/A
DIAG_STAT	Read only	No	0x3C	0x0000	System, status/error flags	Table 26
GLOB_CMD	Write only	No	0x3E	0x0000	System, global commands	Table 23
Reserved	N/A	N/A	0x40 to 0x51	N/A	Reserved	N/A
LOT_ID1	Read only	Yes	0x52	N/A	System, Lot Identification Code 1	Table 27
LOT_ID2	Read only	Yes	0x54	N/A	System, Lot Identification Code 2	Table 27
PROD_ID	Read only	Yes	0x56	0x3FCE	System, product identification	Table 28
SERIAL_NUM	Read only	Yes	0x58	N/A	System, serial number	Table 29

¹ N/A is not applicable.² Each register contains two bytes. The address of the lower byte is displayed. The address of the upper byte is equal to the address of the lower byte plus 1.

OUTPUT DATA REGISTERS

Table 9 provides a summary of the output registers. The most significant bit in each output register provides a new data indicator function. Every time a new data sample loads into the output data registers, the ND bit is a 1, until a read operation accesses the data sample. Then, this bit sets to 0, until the next data sample loads in. The second most significant bit provides an error/alarm indicator. This bit is equal to 1 if any error flag in the DIAG_STAT register is equal to 1 (active).

Table 9. Output Data Register Summary

Register	Address ¹	Function
XGYRO_OUT	0x04	Gyroscope output, x-axis
YGYRO_OUT	0x06	Gyroscope output, y-axis
ZGYRO_OUT	0x08	Gyroscope output, z-axis
XACCL_OUT	0x0A	Accelerometer output, x-axis
YACCL_OUT	0x0C	Accelerometer output, y-axis
ZACCL_OUT	0x0E	Accelerometer output, z-axis
TEMP_OUT	0x10	Gyroscope temperature, x-axis

¹ Lower byte address shown.

Gyroscopes

The output registers for the gyroscopes (angular rate of rotation) are XGYRO_OUT, YGYRO_OUT, and ZGYRO_OUT. Table 10 provides the bit assignments for these registers, along with the digital formatting for converting the digital codes into angular rate values. Table 11 provides several examples for converting the 14-bit, twos complement data into angular rate measurements, and Figure 15 provides the physical/directional reference for these sensors.

Table 10. Gyroscope Register Bit Assignments

Bit(s)	Description
[15]	New data, 1 = new data since last read access
[14]	Error/alarm
[13:0]	Angular rate output data. Twos complement digital format, typical sensitivity = 0.05°/sec per LSB

Table 11. Gyroscope Data Format Examples

Rate ¹	Decimal	Hex	Binary
+300°/sec	+6000 LSB	0x1770	XX01 0111 0111 0000
+0.1°/sec	+2 LSB	0x0002	XX00 0000 0000 0010
+0.05°/sec	+1 LSB	0x0001	XX00 0000 0000 0001
0°/sec	0 LSB	0x0000	XX00 0000 0000 0000
-0.05°/sec	-1 LSB	0x3FFF	XX11 1111 1111 1111
-0.1°/sec	-2 LSB	0x3FFE	XX11 1111 1111 1110
-300°/sec	-6000 LSB	0x2890	XX10 1000 1001 0000

¹ The numbers in the rate column reflect the default range setting, ±300°/sec.

Accelerometers

The output registers for the accelerometers are XACCL_OUT, YACCL_OUT, and ZACCL_OUT. Table 12 provides the bit assignments for these registers, along with the digital formatting for converting the digital codes into angular rate values. Table 13 provides several examples for converting the 14-bit, twos complement data into acceleration measurements, and Figure 15 provides the physical/directional reference for these sensors.

Table 12. Accelerometer Register Bit Assignments

Bit(s)	Description
[15]	New data, 1 = new data since last read access
[14]	Error/alarm
[13:0]	Linear acceleration output data. Twos complement digital format, typical sensitivity = 1 mg/LSB

Table 13. Acceleration, Twos Complement Format

Acceleration	Decimal	Hex	Binary
+5 g	+5000 LSB	0x1388	XX01 0011 1000 1000
+2 mg	+2 LSB	0x0002	XX00 0000 0000 0010
+1 mg	+1 LSB	0x0001	XX00 0000 0000 0001
0 g	0 LSB	0x0000	XX00 0000 0000 0000
-1 mg	-1 LSB	0x3FFF	XX11 1111 1111 1111
-2 mg	-2 LSB	0x3FFE	XX11 1111 1111 1110
-5 g	-5000 LSB	0x2C78	XX10 1100 0111 1000

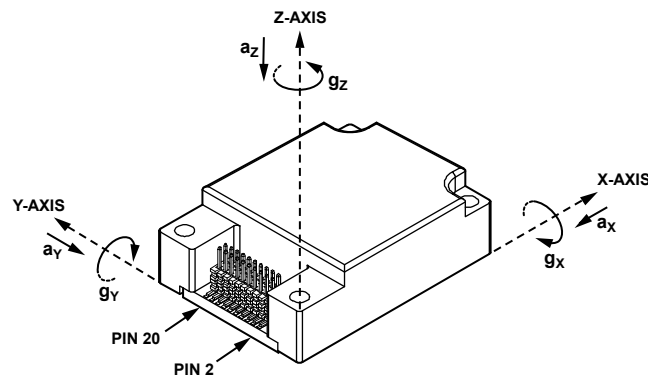

NOTES
 1. ACCELERATION (ax, ay, az) AND ROTATIONAL (gx, gy, gz) ARROWS INDICATE THE DIRECTION OF MOTION THAT PRODUCES A POSITIVE OUTPUT.

Figure 15. Sensor Axes and Orientation Reference Diagram

06362-013

Internal Temperature Measurements

The TEMP_OUT register provides relative temperature measurements for inside of the ADIS16334. This measurement can be above ambient temperature and does not reflect external conditions. Table 14 provides the bit assignments for this register, along with the digital data format. Table 15 provides several examples for converting the 12-bit, offset binary data into temperature measurements.

Table 14. Temperature Register Bit Assignments

Bit(s)	Description
[15]	New data, 1 = new data since last read access
[14]	Error/alarm
[13:12]	Not used
[11:0]	Temperature output data, offset binary format, typical sensitivity = 0.06785°/LSB, 25°C = 0x0000

Table 15. Temperature, Twos Complement Format

Temperature	Decimal	Hex	Binary
+105°C	+1179 LSB	0x49B	XXXX 0100 1001 1011
+85°C	+884 LSB	0x374	XXXX 0011 0111 0100
+25.1537°C	+2 LSB	0x002	XXXX 0000 0000 0010
+25.06785°C	+1 LSB	0x001	XXXX 0000 0000 0001
+25°C	0 LSB	0x000	XXXX 0000 0000 0000
+24.93215°C	-1 LSB	0xFFF	XXXX 1111 1111 1111
+24.8643°C	-2 LSB	0xFFE	XXXX 1111 1111 1110
-40°C	-958 LSB	0xC42	XXXX 1100 0100 0010

DEVICE CONFIGURATION

The control registers in Table 8 provide users with a variety of configuration options. The SPI provides access to these registers, one byte at a time, using the bit assignments in Figure 14. Each register has 16 bits, where Bits[7:0] represent the lower address, and Bits[15:8] represent the upper address. Figure 16 provides an example of writing 0x03 to Address 0x37 (SMPL_PRD[15:8]), using DIN = 0xB703. This example reduces the sample rate by a factor of eight (see Table 17).

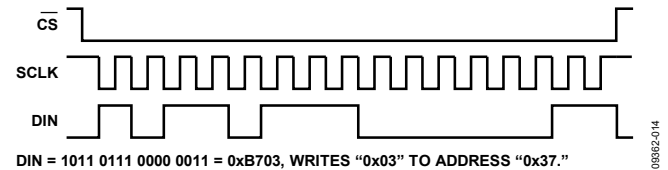

Figure 16. Example SPI Write Sequence

Dual Memory Structure

Writing configuration data to a control register updates its SRAM contents, which are volatile. After optimizing each relevant control register setting in a system, set GLOB_CMD[3] = 1 (DIN = 0xBE08) to back these settings up in nonvolatile flash memory. The flash backup process requires a valid power supply level for the entire 75 ms process time. The user register map in Table 8 provides a column that indicates the registers that have flash back-up support. A yes in the Flash Backup column indicates that a register has a mirror location in flash and, when backed up properly, it automatically restores itself during startup or after a reset. Figure 17 provides a diagram of the dual-memory structure used to manage operation and store critical user settings.

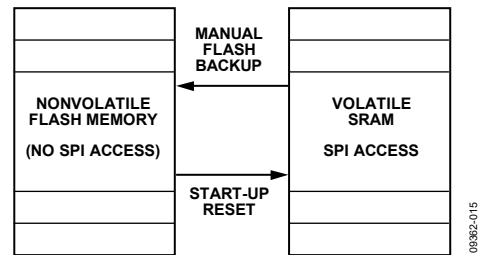

Figure 17. SRAM and Flash Memory Diagram

DIGITAL PROCESSING CONFIGURATION

Table 16. Digital Processing Registers

Register Name	Address	Description
SMPL_PRD	0x36	Sample rate control
SENS_AVG	0x38	Digital filtering and range control

SAMPLE RATE

The internal sampling system produces new data in the output data registers at a rate of 819.2 SPS. The SMPL_PRD register in Table 17 provides two functional controls for internal sampling and register update rates: SMPL_PRD[12:8] for decimation and SMPL_PRD[0] for enabling the external clock option. The decimation filter reduces the update rate, using an averaging filter with a decimated output. These bits provide a binomial control that divides the data rate by a factor of 2 every time this number increases by 1. For example, set SMPL_PRD[12:8] = 00100 (DIN = 0xB704) to set the decimation factor to 16. This reduces the update rate to 51.2 SPS and the bandwidth to 25 Hz.

Table 17. SMPL_PRD Bit Descriptions

Bit(s)	Description (Default = 0x0001)
[15:13]	Not used
[12:8]	Average/decimation rate setting, binomial
[7:1]	Not used
[0]	Clock: 1 = internal (819.2 SPS), 0 = external

INPUT CLOCK CONFIGURATION

SMPL_PRD[0] provides a control for synchronizing the internal sampling to an external clock source. Set SMPL_PRD[0] = 0 (DIN = 0xB600) to enable the external clock. See Table 2 and Figure 4 for timing information.

DIGITAL FILTERING

The SENS_AVG register in Table 18 provides user controls for the low-pass filter. This filter contains two cascaded averaging filters that provide a Bartlett window, FIR filter response (see Figure 19). For example, set SENS_AVG[2:0] = 100 (DIN = 0xB804) to set each stage to 16 taps. When used with the default sample rate of 819.2 SPS and zero decimation (SMPL_PRD[12:8] = 00000), this value reduces the sensor bandwidth to approximately 16 Hz.

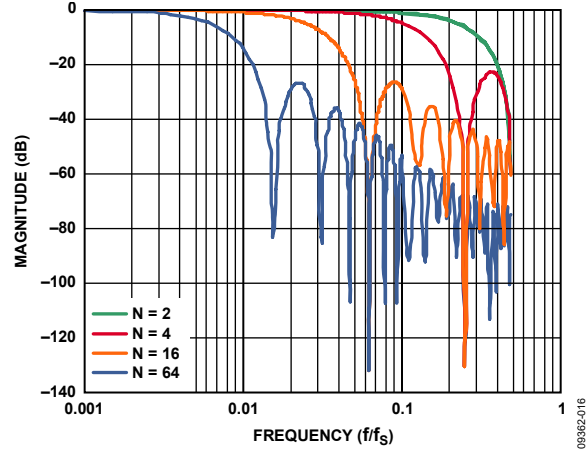

Figure 18. Bartlett Window, FIR Filter Frequency Response (Phase Delay = N Samples)

DYNAMIC RANGE

The SENS_AVG[10:8] bits provide three dynamic range settings for this gyroscope. The lower dynamic range settings ($\pm 75^\circ/\text{sec}$ and $\pm 150^\circ/\text{sec}$) limit the minimum filter tap sizes to maintain resolution. For example, set SENS_AVG[10:8] = 010 (DIN = 0xB902) for a measurement range of $\pm 150^\circ/\text{sec}$. Because this setting can influence the filter settings, program SENS_AVG[10:8] before programming SENS_AVG[2:0] if additional filtering is required.

Table 18. SENS_AVG Bit Descriptions

Bits	Description (Default = 0x0402)
[15:11]	Not used
[10:8]	Measurement range (sensitivity) selection 100 = $\pm 300^\circ/\text{sec}$ (default condition) 010 = $\pm 150^\circ/\text{sec}$, filter taps ≥ 4 (Bits[2:0] $\geq 0x02$) 001 = $\pm 75^\circ/\text{sec}$, filter taps ≥ 16 (Bits[2:0] $\geq 0x04$)
[7:3]	Not used
[2:0]	Number of taps in each stage; value of B in $N_B = 2^B$

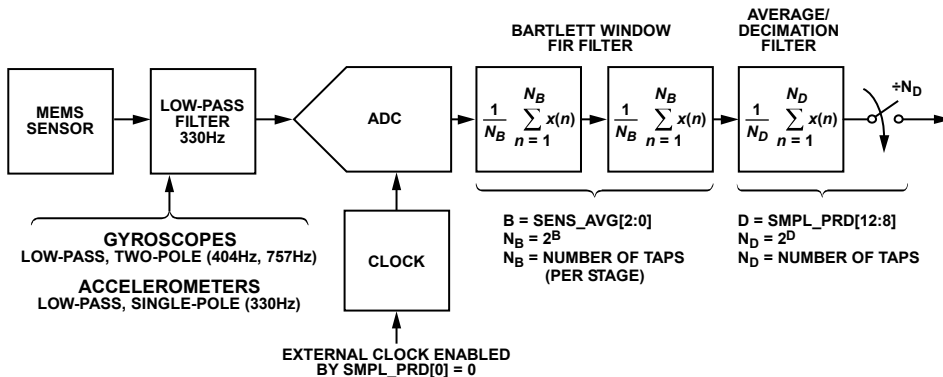

Figure 19. Sampling and Frequency Response Block Diagram

OPTIMIZING ACCURACY

The mechanical structure and assembly process of the ADIS16334 provide excellent position and alignment stability for each sensor, even after subjected to temperature cycles, shock, vibration, and other environmental conditions. The factory calibration includes a dynamic characterization of each sensor's behavior over temperature and generates sensor-specific correction formulas. The bias correction registers in Table 19 provide users with the ability to address bias shifts that can result from mechanical stress. Figure 20 illustrates the summing function of each sensor's offset correction register.

Table 19. Registers for User Calibration

Register	Address	Description
XGYRO_OFF	0x1A	Gyroscope bias, x-axis
YGYRO_OFF	0x1C	Gyroscope bias, y-axis
ZGYRO_OFF	0x1E	Gyroscope bias, z-axis
XACCL_OFF	0x20	Accelerometer bias, x-axis
YACCL_OFF	0x22	Accelerometer bias, y-axis
ZACCL_OFF	0x24	Accelerometer bias, z-axis
GLOB_CMD	0x3E	Automatic calibration

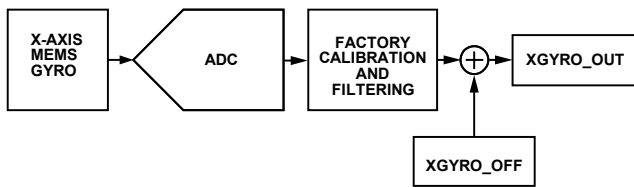

Figure 20. User Calibration, XGYRO_OFF Example

There are two options for optimizing gyroscope bias accuracy prior to system deployment: automatic bias correction (ABC) and manual bias correction (MBC).

AUTOMATIC BIAS CORRECTION

The ABC function provides a simple measure-and-adjust function for the three gyroscope sensors. Set GLOB_CMD[0] = 1 (DIN = 0xBE01) to start the ABC function, which automatically performs the following steps to correct the bias on each gyroscope:

1. Sets the output range to $\pm 75^\circ/\text{sec}$
2. Waits for the next output register update
3. Reads the output register of the gyroscope
4. Multiplies the measurement by -1 to change its polarity
5. Writes the final value into the offset register
6. Performs a manual flash back-up function to store the correction factor in nonvolatile flash memory

The accuracy of the bias correction depends on the internal averaging time used for the data sample, which depends on the decimation setting. For example, set SMPL_PRD[15:8] = 0x10 (DIN = 0xB710) to establish a decimation rate of 2^{16} , or 65536. This establishes an averaging time of 80 seconds at a sample rate of 819.2 SPS, which results in an Allan Variance of $0.006^\circ/\text{sec}$ in Figure 7.

MANUAL BIAS CORRECTION

The MBC function requires the user to collect the desired number of samples, calculate the averages to develop bias estimates for each gyroscope channel, and then write them into the bias offset registers, located in Table 20 for the gyroscopes. For example, set XGYRO_OFF = 0x1FF6 (DIN = 0x9B1F, 0x9AF6) to adjust the XGYRO_OUT offset by $-0.125^\circ/\text{sec}$ (-10 LSBs). Table 21 provides a manual adjustment function for the accelerometer channels as well.

Table 20. XGYRO_OFF, YGYRO_OFF, and ZGYRO_OFF Bit Descriptions

Bits	Description (Default = 0x0000)
[15:13]	Not used
[12:0]	Data bits. Twos complement, $0.0125^\circ/\text{sec}$ per LSB. Typical adjustment range = $\pm 50^\circ/\text{sec}$.

Table 21. XACCL_OFF, YACCL_OFF, and ZACCL_OFF Bit Descriptions

Bits	Description (Default = 0x0000)
[15:12]	Not used
[11:0]	Data bits. Twos complement, 1mg/LSB. Typical adjustment range = $\pm 2 g$.

RESTORING FACTORY CALIBRATION

Set GLOB_CMD[1] = 1 (DIN = 0xBE02) to execute the factory calibration restore function. This is a single-command function, which resets each user calibration register to 0x0000 and all sensor data to 0. Then, it automatically updates the flash memory within 50 ms. See Table 23 for more information on GLOB_CMD.

POINT-OF-PERCUSSION/LINEAR-g COMPENSATION

Set MSC_CTRL[6] = 1 (DIN = 0xB446) to enable this feature and maintain the factory-default settings for DIO1. This feature performs a point-of-percussion translation to the point identified in Figure 6. See Table 25 for more information on MSC_CTRL. Set MSC_CTRL[7] = 1 to enable internal compensation for linear-g on the gyroscope bias.

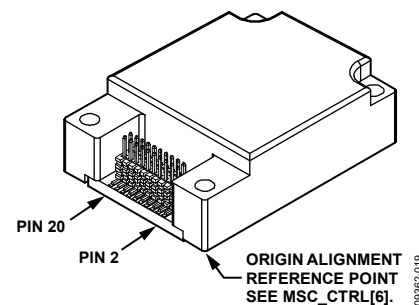

Figure 21. Point of Percussion Reference

SYSTEM TOOLS

Table 22 provides an overview of the control registers that provide support for the following system level functions: global commands, I/O control, status/error flags, device identification, MEMS self-test, and flash memory management.

Table 22. System Tool Register Addresses

Register Name	Address	Description
FLSH_CNT	0x00	Flash write cycle count
GPIO_CTRL	0x32	General-purpose I/O control
MSC_CTRL	0x34	Manual self-test controls
DIAG_STAT	0x3C	Status, error flags
GLOB_CMD	0x3E	Global commands
LOT_ID1	0x52	Lot Identification Code 1
LOT_ID2	0x54	Lot Identification Code 2
PROD_ID	0x56	Product identification
SERIAL_NUM	0x58	Serial number

GLOBAL COMMANDS

The GLOB_CMD register provides an array of single-write commands for convenience. Setting the assigned bit in Table 23 to 1 activates each function. When the function completes, the bit restores itself to 0. For example, clear the capture buffers by setting GLOB_CMD[8] = 1 (DIN = 0xBF01). All of the commands in the GLOB_CMD register require the power supply to be within normal limits for the execution times listed in Table 23. Avoid communicating with the SPI interface during these execution times because it interrupts the process and causes data loss or corruption.

Table 23. GLOB_CMD Bit Descriptions

Bit(s)	Description	Execution Time ¹
[15:8]	Not used	Not applicable
[7]	Software reset	60 ms
[6:4]	Not used	Not applicable
[3]	Register back-up to flash	
[2]	Not used	Not applicable
[1]	Factory calibration restore	
[0]	Gyroscope auto-null	

¹ This indicates the typical duration of time between the command write and the device returning to normal operation.

General-Purpose I/O

DIO1, DIO2, DIO3, and DIO4 are configurable, general-purpose I/O lines that serve multiple purposes according to the following control register priority: MSC_CTRL, ALM_CTRL, and GPIO_CTRL. For example, set GPIO_CTRL = 0x080C (DIN = 0xB308, and then 0xB20C) to configure DIO1 and DIO2 as inputs and DIO3 and DIO4 as outputs, with DIO3 set low and DIO4 set high. In this configuration, read GPIO_CTRL (DIN = 0x3200). The digital state of DIO1 and DIO2 is in GPIO_CTRL[9:8].

Table 24. GPIO_CTRL Bit Descriptions

Bit(s)	Description (Default = 0x0000)
[15:12]	Not used
[11]	General-Purpose I/O Line 4 (DIO4) data level
[10]	General-Purpose I/O Line 3 (DIO3) data level
[9]	General-Purpose I/O Line 2 (DIO2) data level
[8]	General-Purpose I/O Line 1 (DIO1) data level
[7:4]	Not used
[3]	General-Purpose I/O Line 4 (DIO4) direction control (1 = output, 0 = input)
[2]	General-Purpose I/O Line 3 (DIO3) direction control (1 = output, 0 = input)
[1]	General-Purpose I/O Line 2 (DIO2) direction control (1 = output, 0 = input)
[0]	General-Purpose I/O Line 1 (DIO1) direction control (1 = output, 0 = input)

Data Ready I/O Indicator

The factory default sets DIO1 as a positive data ready indicator signal. In this configuration, the signal pulses high when all of the output data registers have fresh data from the same sample period. The MSC_CTRL[2:0] bits provide configuration options for changing the default. For example, set MSC_CTRL[2:0] = 100 (DIN = 0xB404) to change the polarity of the data ready signal on DIO1 for interrupt inputs that require negative logic inputs for activation. See Figure 4 for an example of the data-ready timing.

Table 25. MSC_CTRL Bit Descriptions

Bit(s)	Description (Default = 0x0006)
[15:12]	Not used
[11]	Memory test (cleared upon completion) (1 = enabled, 0 = disabled)
[10]	Internal self-test enable (cleared upon completion) (1 = enabled, 0 = disabled)
[9:8]	Not used
[7]	Linear acceleration bias compensation for gyroscopes (1 = enabled, 0 = disabled)
[6]	Linear accelerometer origin alignment (1 = enabled, 0 = disabled)
[5:3]	Not used
[2]	Data ready enable (1 = enabled, 0 = disabled)
[1]	Data ready polarity (1 = active high, 0 = active low)
[0]	Data ready line select (1 = DIO2, 0 = DIO1)

Self-Test

The self-test function allows the user to verify the mechanical integrity of each MEMS sensor. It applies an electrostatic force to each sensor element, which results in mechanical displacement that simulates a response to actual motion. Table 1 lists the expected response for each sensor and provides pass/fail criteria.

Set MSC_CTRL[10] = 1 (DIN = 0xB504) to run the internal self-test routine, which exercises all inertial sensors, measures each response, makes pass/fail decisions, and reports them to error flags in the DIAG_STAT register. MSC_CTRL[10] resets itself to 0 after completing the routine. Zero rotation provides results that are more reliable.

Memory Test

Setting MSC_CTRL[11] = 1 (DIN = 0xB508) performs a checksum verification of the flash memory locations. The pass/fail result is loaded into DIAG_STAT[6].

Status

The error flags provide indicator functions for common system level issues. All of the flags are cleared (set to 0) after each DIAG_STAT register read cycle. If an error condition remains, the error flag returns to 1 during the next sample cycle. The DIAG_STAT[1:0] bits do not require a read of this register to return to 0. If the power supply voltage goes back into range, these two flags are cleared automatically.

Table 26. DIAG_STAT Bit Descriptions

Bit(s)	Description (Default = 0x0000)
[15]	Z-axis accelerometer self-test failure (1 = fail, 0 = pass)
[14]	Y-axis accelerometer self-test failure (1 = fail, 0 = pass)
[13]	X-axis accelerometer self-test failure (1 = fail, 0 = pass)
[12]	Z-axis gyroscope self-test failure (1 = fail, 0 = pass)
[11]	Y-axis gyroscope self-test failure (1 = fail, 0 = pass)
[10]	X-axis gyroscope self-test failure (1 = fail, 0 = pass)
[9]	Alarm 2 status (1 = active, 0 = inactive)
[8]	Alarm 1 status (1 = active, 0 = inactive)
[7]	Not used
[6]	Flash test, checksum flag (1 = fail, 0 = pass)
[5]	Self-test diagnostic error flag (1 = fail, 0 = pass)
[4]	Sensor overrange (1 = fail, 0 = pass)
[3]	SPI communication failure (1 = fail, 0 = pass)
[2]	Flash update failure (1 = fail, 0 = pass)
[1:0]	Not used

DEVICE IDENTIFICATION

Table 27. LOT_ID1 and LOT_ID2 Bit Descriptions

Bits	Description
[15:0]	Lot identification code

Table 28. PROD_ID Bit Descriptions

Bits	Description
[15:0]	0x3FCE = 16,334 (decimal)

Table 29. SERIAL_NUM Bit Descriptions

Bits	Description
[15:0]	Serial number, lot specific

FLASH MEMORY MANAGEMENT

Set MSC_CTRL[11] = 1 (DIN = 0xB508) to run an internal checksum test on the flash memory, which reports a pass/fail result to DIAG_STAT[6]. The FLASH_CNT register (see Table 30) provides a running count of flash memory write cycles. This is a tool for managing the endurance of the flash memory. Figure 22 quantifies the relationship between data retention and junction temperature.

Table 30. FLASH_CNT Bit Descriptions

Bits	Description
[15:0]	Binary counter for writing to flash memory

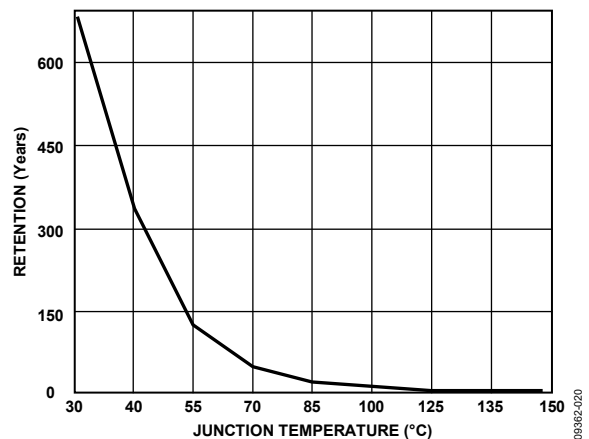

Figure 22. Flash/EE Memory Data Retention

ALARMS

The ADIS16334 provides two independent alarms, Alarm 1 and Alarm 2, which have a number of programmable settings. Table 31 provides a list of registers for these user settings.

Table 31. Registers for Alarm Configuration

Register	Address	Description
ALM_MAG1	0x26	Alarm 1 trigger setting
ALM_MAG2	0x28	Alarm 2 trigger setting
ALM_SMPL1	0x2A	Alarm 1 sample period
ALM_SMPL2	0x2C	Alarm 2 sample period
ALM_CTRL	0x2E	Alarm configuration

The ALM_CTRL register in Table 35 provides data source selection (Bits[15:8]), static/dynamic setting for each alarm (Bits[7:6]), data source filtering (Bit[4]), and alarm indicator signal (Bits[2:0]).

STATIC ALARM USE

The static alarms setting compares the data source selection (ALM_CTRL[15:8]) with the values in the ALM_MAGx registers in Table 32 and Table 33. The data format in these registers matches the format of the data selection in ALM_CTRL[15:8]. The MSB (Bit[15]) of each ALM_MAGx register establishes the polarity for this comparison. See Table 36, Alarm 1, for a static alarm configuration example.

Table 32. ALM_MAG1 Bit Descriptions

Bit(s)	Description (Default = 0x0000)
[15]	Trigger polarity, 1= greater than, 0 = less than
[14]	Not used
[13:0]	Threshold setting; matches for format of ALM_CTRL[11:8] output register selection

Table 33. ALM_MAG2 Bit Descriptions

Bit(s)	Description (Default = 0x0000)
[15]	Trigger polarity, 1= greater than, 0 = less than
[14]	Not used
[13:0]	Threshold setting; matches for format of ALM_CTRL[15:12] output register selection

DYNAMIC ALARM USE

The dynamic alarm setting monitors the data selection for a rate-of-change comparison. The rate-of-change comparison is represented by the magnitude in the ALM_MAGx registers over the time represented by the number-of-samples setting in the ALM_SMPLx registers located in Table 34. See Table 36, Alarm 2, for a dynamic alarm configuration example.

Table 34. ALM_SMPL1 and ALM_SMPL2 Bit Descriptions

Bits	Description (Default = 0x0000)
[15:8]	Not used
[7:0]	Binary, number of samples (both 0x00 and 0x01 = 1)

ALARM REPORTING

The DIAG_STAT[9:8] bits provide error flags that indicate an alarm condition. The ALM_CTRL[2:0] bits provide controls for a hardware indicator using DIO1 or DIO2.

Table 35. ALM_CTRL Bit Descriptions

Bit(s)	Description (Default = 0x0000)
[15:12]	Alarm 2 data source selection 0000 = disable 0001 = x-axis gyroscope output 0010 = y-axis gyroscope output 0011 = z-axis gyroscope output 0100 = x-axis accelerometer output 0101 = y-axis accelerometer output 0110 = z-axis accelerometer output 0111 = internal temperature output
[11:8]	Alarm 1 data source selection (same as Alarm 2)
[7]	Alarm 2, dynamic/static (1 = dynamic, 0 = static)
[6]	Alarm 1, dynamic/static (1 = dynamic, 0 = static)
[5]	Not used
[4]	Data source filtering (1 = filtered, 0 = unfiltered)
[3]	Not used
[2]	Alarm indicator (1 = enabled, 0 = disabled)
[1]	Alarm indicator active polarity (1 = high, 0 = low)
[0]	Alarm output line select (1 = DIO2, 0 = DIO1)

Alarm Example

Table 36 offers an example that configures Alarm 1 to trigger when filtered ZACCL_OUT data drops below 0.7 g, and Alarm 2 to trigger when filtered ZGYRO_OUT data changes by more than 50°/sec over a 100 ms period, or 500°/sec². The filter setting helps reduce false triggers from noise and refine the accuracy of the trigger points. The ALM_SMPL2 setting of 82 samples provides a comparison period that is 97.7 ms for an internal sample rate of 819.2 SPS.

Table 36. Alarm Configuration Example 1

DIN	Description
0xAF36, 0xAE97	ALM_CTRL = 0x3697. Alarm 2: dynamic, $\Delta ZGYRO_OUT$ (Δ -time, ALM_SMPL2) > ALM_MAG2. Alarm 1: static, ZACCL_OUT < ALM_MAG1. Use filtered data source for comparison. DIO2 output indicator, positive polarity.
0xA983, 0xA8E8	ALM_MAG2 = 0x83E8 (true if $\Delta ZGYRO_OUT$ > 50°/sec) $50^\circ/\text{sec} \div 0.05^\circ/\text{sec per LSB} = 1000 = 0x03E8$, ALM_MAG2[15] = 1 for greater than.
0xA702, 0xA6BC	ALM_MAG1 = 0x02BC (true if ZACCL_OUT < 0.7g) $0.7\text{ g} \div 1\text{ mg/LSB} = 700\text{ LSB} = 0x02BC$, ALM_MAG1[15] = 0 for less than.
0xAC66	ALM_SMPL2[7:0] = 0x52 (82 samples).

APPLICATIONS INFORMATION

MOUNTING TIPS

The mounting and installation process can influence gyroscope bias repeatability and other key parametric behaviors. To preserve the best performance, use the following guidelines when developing an attachment approach for the ADIS16334:

- Focus mounting force at the machine screw locations.
- Avoid direct force application on the substrate.
- Avoid placing mounting pressure on the package lid, except for the edges that border the exposed side of the substrate.
- Use a consistent mounting torque of 28 inch-ounces on mounting hardware.
- Avoid placing translational forces on the electrical connector.

For additional information about mounting ideas and tips, refer to [Application Note AN-1305](#) and [Application Note AN-1146](#).

POWER SUPPLY CONSIDERATIONS

The power supply must be within 4.75 V and 5.25 V for normal operation and optimal performance. During start up, the internal power conversion system starts drawing current when VDD reaches 1.6 V. The internal processor begins initializing when VDD is equal to 2.35 V. After the processor starts, VDD must reach 2.7 V within 128 ms. Ensure that the power supply drops below 1.6 V to shut down the device.

BREAKOUT BOARDS

The [ADIS1644X/FLEX](#) and [ADIS16IMU2/PCBZ](#) evaluation tools combine to provide a simplified method for connecting the ADIS16334 to an embedded processor system, or to the [EVAL-ADIS2](#) evaluation system. See the [ADIS16IMU2/PCBZ Breakout Board Wiki-Guide](#) for more information on using these tools to connect the ADIS16334.

EVALUATION SYSTEM

The [EVAL-ADIS2](#) evaluation system, in conjunction with the [ADIS1644X/FLEX](#) and [ADIS16IMU2/PCBZ](#), provides a simplified method for evaluating the ADIS16334, using a personal computer platform. Refer to the [EVAL-ADIS2 Evaluation System Wiki Guide](#), for more information on using these tools to evaluate the ADIS16334.

ADIS16IMU2/PCBZ

The [ADIS1644X/FLEX](#) and [ADIS16IMU2/PCBZ](#) accessories provide a simple method for connecting to an embedded processor platform or to the [EVAL-ADIS2](#) evaluation system. Figure 24 provides a mechanical design example for using these two components with the ADIS16334 inertial measurement unit (IMU) in a system.

Figure 23 provides the pin assignments for J1 on the [ADIS16IMU2/PCBZ](#) breakout board.

J1		
RST	1	2 SCLK
CS	3	4 DOUT
DNC	5	6 DIN
GND	7	8 GND
GND	9	10 VDD
VDD	11	12 VDD
DIO1	13	14 DIO2
DIO3	15	16 DIO4/CLKIN

Figure 23. J1 Pin Assignments for the [ADIS16IMU2/PCBZ](#)

The C1 and C2 locations on the [ADIS16IMU2/PCBZ](#) provide users with the pads to install decoupling capacitance across VDD and GND.

PC-BASED EVALUATION TOOLS

The [EVAL-ADIS2](#) supports PC-based evaluation of the ADIS16334. Please refer to the [EVAL-ADIS2 Evaluation System Wiki Guide](#), for more information on connecting the ADIS16334 to the [EVAL-ADIS2](#) system.

X-RAY SENSITIVITY

Exposure to high dose rate X-rays, such as those in production systems that inspect solder joints in electronic assemblies, may affect accelerometer bias errors. For optimal performance, avoid exposing the ADIS16334 to this type of inspection.

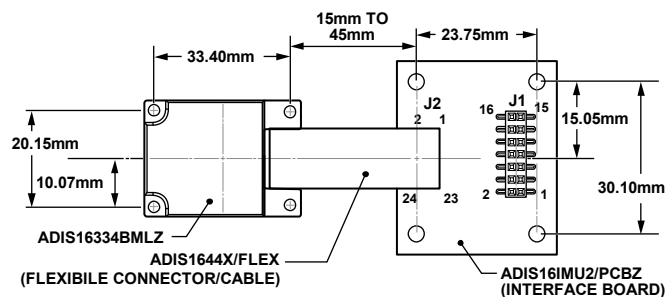

- NOTES
1. USE FOUR M2 MACHINE SCREWS TO ATTACH THE ADIS16334.
 2. USE FOUR M3 MACHINE SCREWS TO ATTACH THE INTERFACE PCB.

Figure 24. Physical Diagram for ADIS16334 Accessories

OUTLINE DIMENSIONS

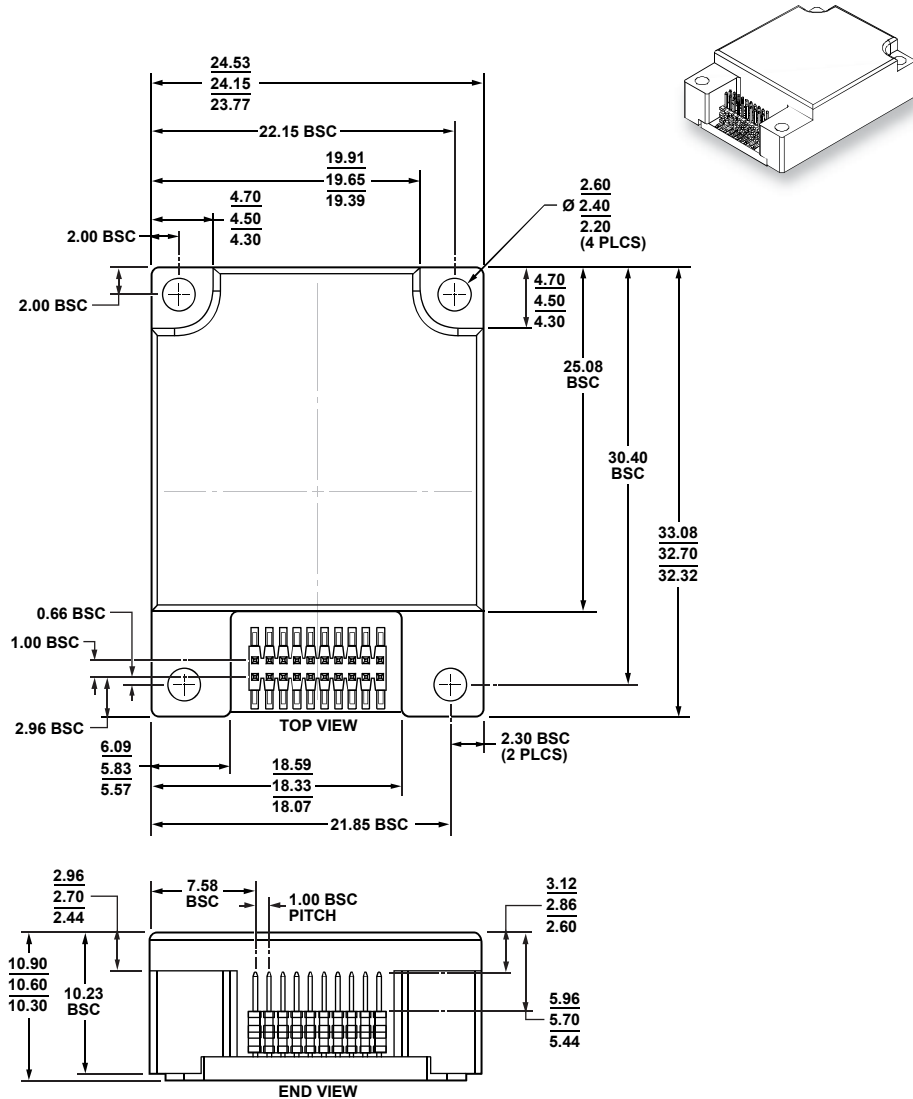

Figure 25. 20-Lead Module with Connector Interface (ML-20-1)
Dimensions shown in millimeters

01-18-2011-B

ORDERING GUIDE

Model ¹	Temperature Range	Package Description	Package Option
ADIS16334BMLZ	-40°C to +105°C	20-Lead Module with Connector Interface	ML-20-1
ADIS161MU2/PCBZ		Breakout Board	
ADIS1644X/FLEX		Flexible Connector	
EVAL-ADIS2Z		Evaluation System	

¹ Z = RoHS Compliant Part.