

REVISIONS					
REV	ECO	DESCRIPTION	DATE	BY	APPR
A	-	RELEASE	10/SEP/13	DRP	

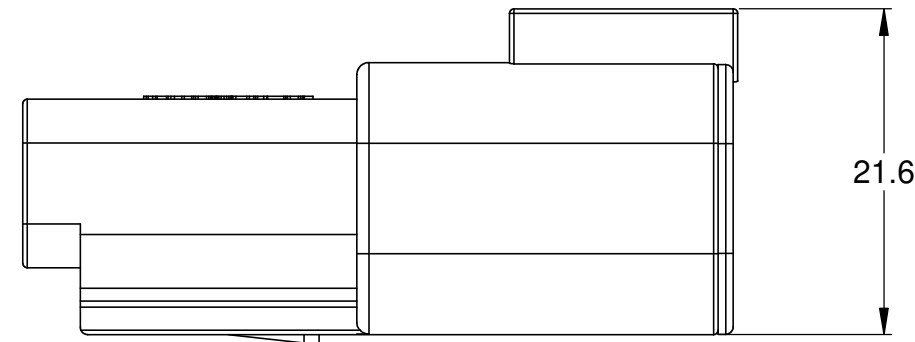
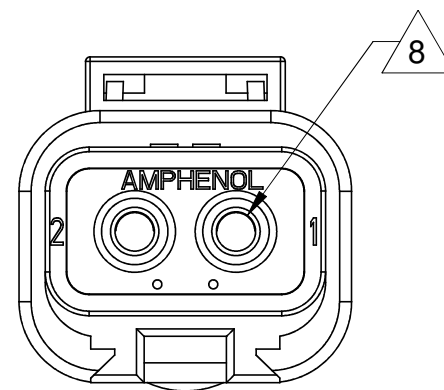
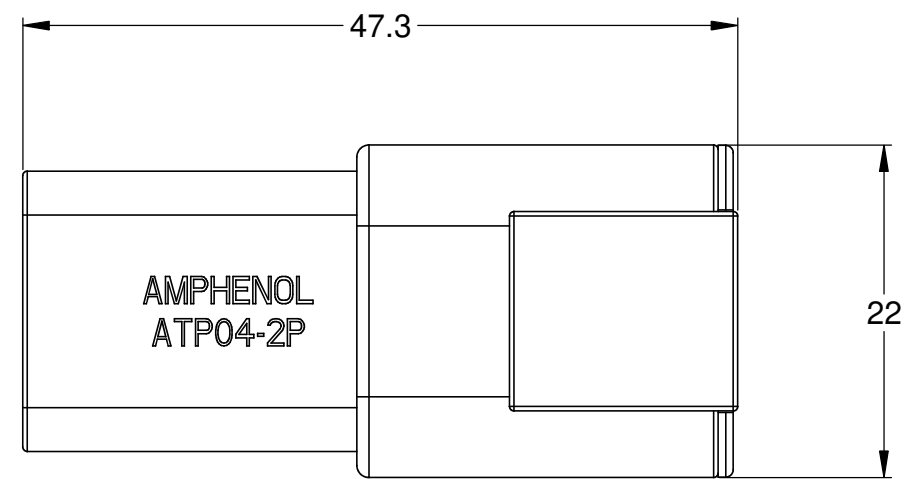
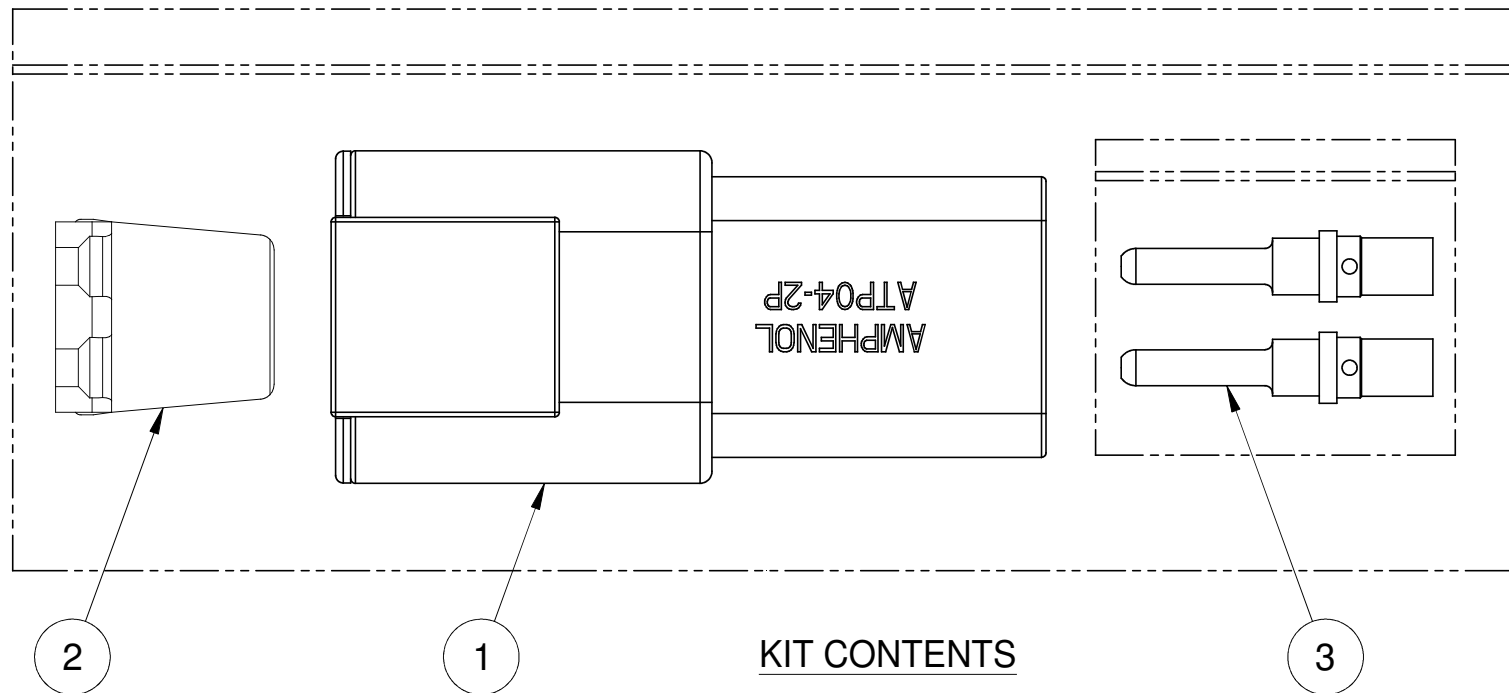

NOTES: UNLESS OTHERWISE SPECIFIED

1. MATERIAL:

HOUSING: THERMOPLASTIC; COLOR: GREY
 WEDGELOCK: THERMOPLASTIC; COLOR: ORANGE
 SEALS: SILICONE RUBBER
 CONTACTS: COPPER ALLOY; NICKEL PLATED

2. SPECIFICATIONS:

- 2.1 CURRENT RATING: 25 AMPS
- 2.2 OPERATING TEMPERATURE: -55°C TO +125°C
- 2.3 DIELECTRIC WITHSTANDING VOLTAGE: LESS THAN 2 MILLIAMPS CURRENT LEAKAGE @ 1500 VOLTS AC.
- 2.4 INSULATION RESISTANCE: 1000 MEGOHMS MIN @ 25°C.
- 2.5 CONTACT MILLIVOLT DROP: 60 MILLIVOLT DROP @ 25 AMP TEST CURRENT.
- 2.6 MOISTURE RESISTANCE: IP67 (MATED CONDITION)
- 2.7 CONNECTOR MATING CYCLE DURABILITY: 100 CYCLES

3. MATING PART: ATP06-2S* PLUG
 (* = MODIFICATIONS AND COLORS)

4. AVAILABLE HAND CRIMPER: CA-5D12

5. ALL COMPONENTS ARE RoHS COMPLIANT.

6. ALL DIMENSIONS ARE FOR REFERENCE USE ONLY.

7 WIRE RANGE OF CONTACTS INCLUDED IN KIT: 12 - 14 AWG

8 CONTACT SIZE AND REAR SEAL WIRE RANGE:

CONTACT SIZE	MIN. INSUL. O.D.	MAX. INSUL. O.D.	TYPICAL WIRE RANGE
12	3.40 mm (.134 in)	4.95 mm (.195 in)	10 - 14 AWG

REFERENCE DIMENSIONS - ASSEMBLED

QUANTITY	PART NUMBER	DESCRIPTION	ITEM
2	AT60-204-12141	CONTACT, PIN, SOLID, SIZE 12, 12 - 14 AWG	3
1	AWP-2P	P-WEDGELOCK, 2 POSITION, ATP SERIES	2
1	ATP04-2P	RECEPTACLE, 2 POSITION, ATP SERIES	1

MATERIALS LIST

UNLESS OTHERWISE SPECIFIED		SIGNATURES		DATE
1) All dimensions are in metric (mm). 2) Tolerances are as follows: 1 PL DEC ±0.30 2 PL DEC ±0.15 3 PL DEC ±0.08		D.PARKS		10/SEP/13
Fractions ±1/64 Angles ±1°		CHECKED:		
3) Note reference = X		ENGINEER:		
MATERIAL SPECIFICATIONS:		APPROVAL:		
PROCESS SPECIFICATIONS:		CUSTOMER:		
NEXT ASSY:		THIS DRAWING IS SUPPLIED FOR INFORMATION ONLY. DESIGN FEATURES, SPECIFICATIONS AND PERFORMANCE DATA SHOWN HEREON ARE THE PROPERTY OF THE AMPHENOL CORPORATION. NO RIGHTS OF REPRODUCTION ARE IMPLIED. ALL DIMENSIONS ARE SUBJECT TO NORMAL MANUFACTURING VARIATIONS.		
<p>Sine Systems - www.amphenol-sine.com 44724 Morley Drive Clinton Township, MI 48036</p>			KIT, ATP SERIES, 2 POSITION, RECEPTACLE, CONTACTS, AND WEDGELOCK	
			SIZE: B	TYPE: C-
SCALE: NONE			SHEET 1 OF 1	

TITLE: KIT ATP SERIES, 2 POSITION, RECEPTACLE, CONTACTS, & WEDGELOCK
 DWG NO: ATP04-2P-KIT01
 REV: A
 SH: 1
 OF: 1