

Overview

KEMET's Pyroelectric Infrared Sensors have a low profile design and can be used without a lens to enable miniaturized designs and are ideal to detect human proximity by IR presence.

KEMET's proprietary piezoelectric ceramic material and structural development of the pyroelectric infrared sensor enables human presence detection through solid plastic materials or glass, which allows more mechanical and optical appearance design possibilities of the end product. The sensor can be used without a lens or, to extend the detection range, a proprietary KEMET lens can be used in 3 different colors.

Applications

Typical applications include human presence detection sensing for energy saving functions in:

- Contact less switching
- Office automation equipment
- Home appliances
- Lighting
- Display products
- Air-conditioners
- TV
- PC monitors
- Rice cookers
- Smart toilets

Benefits

- Reflow capable SMD configuration
- Lens not required
- A lens can be attached to the sensor
- Wide view angle up to ± 60 degrees (lensless)
- View angle up to $\pm 37/\pm 28$ degrees (with lens)
- Detection possible through glass or resin
- Low power consumption, down in the μA range
- Excellent radio wave performance in high-frequency band
- Compact and low profile (5.0 x 4.8 x 1.7 mm)

Sensor - Front

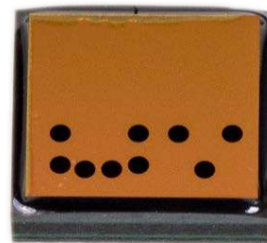

Sensor - Back

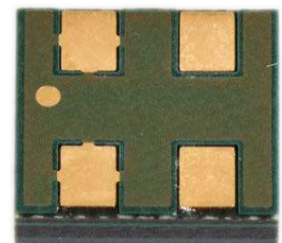

Natural Lens



White Lens



Black Lens



Ordering Information

PL-	N	823-	01
Series	Lens Type	Sensor Type	Serial Number
PL	N = Lens not supported Q = Lens supported ¹	823 873	01 02

¹ The Lens Type "Q = Lens supported" is not including the lens itself, to be selected and purchased separately, as per below table.

PL-	001L-	N
Series	Lens Type	Color Type
PL	001L	BK = Black N = Natural W = White

Performance Characteristics

Measuring Method

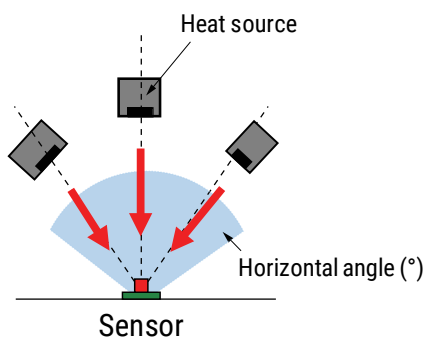

Detected Distance (m)

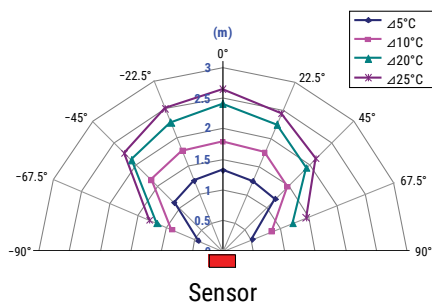

ΔT (°C) = Difference between room temperature and heat source temperature

Performance Characteristics cont.

PL-001L-N - Field of View (Unit: m)

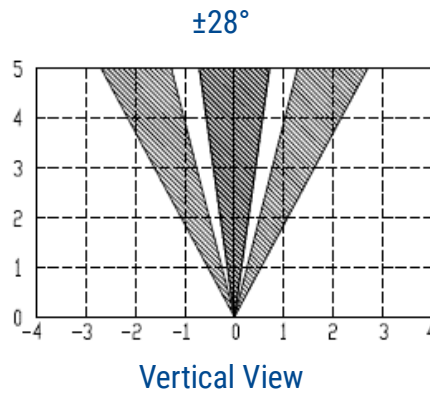
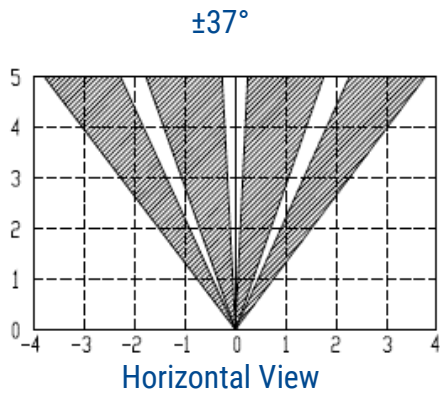

PL-001L-N - Projection View

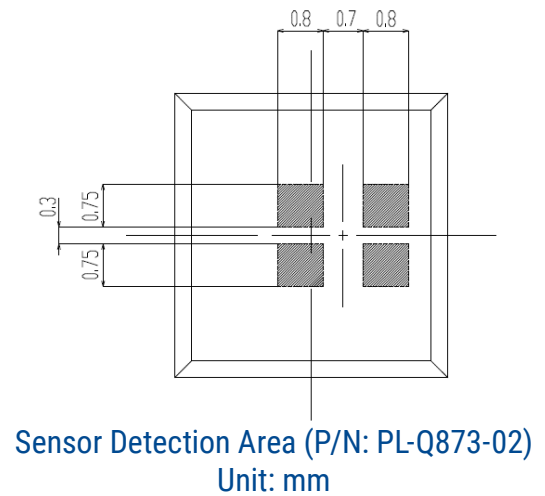
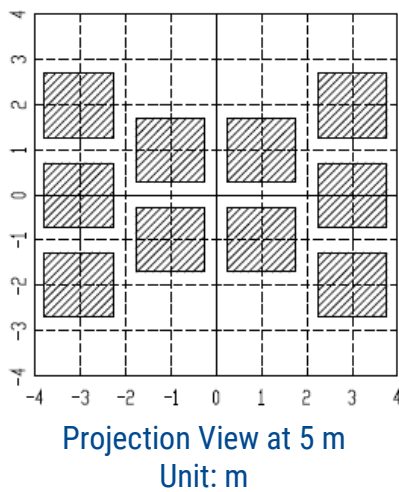

Detecting Performance with Different Materials

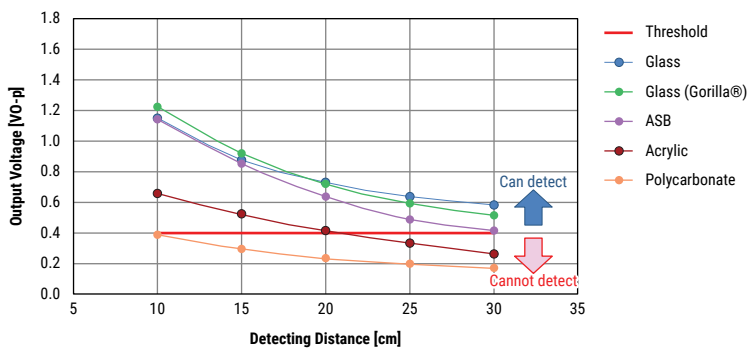

Measuring conditions: Transfer velocity - 1 m/s
Heat source size - 170×70 mm (relative to hand)
Temperature difference - $\Delta 10^\circ\text{C}$
Each material thickness - 1 mm (clear color)

Dimensions in mm

Sensor - Dimensions in mm

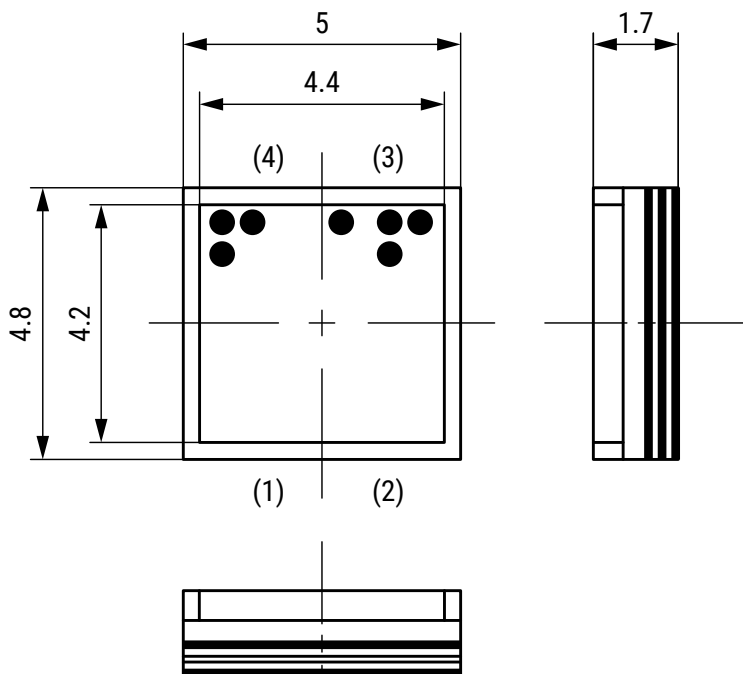

Sensor - Land Pattern in mm

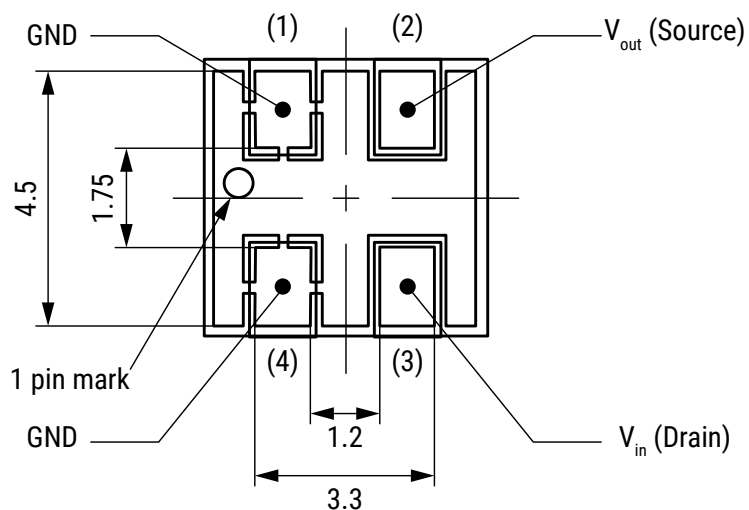
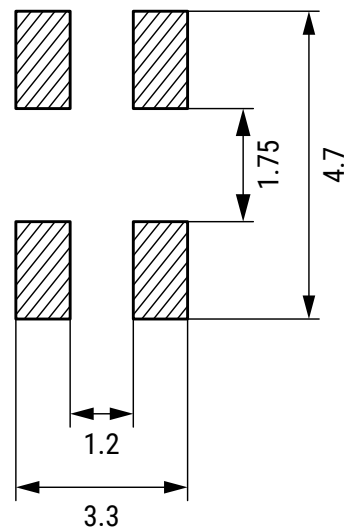

Sensor - Pin Assignment

Pin Number	Pin Name
1	GND
2	V_{out} (Source)
3	V_{in} (Drain)
4	GND

Dimensions in mm cont.

Lens - Dimensions in mm

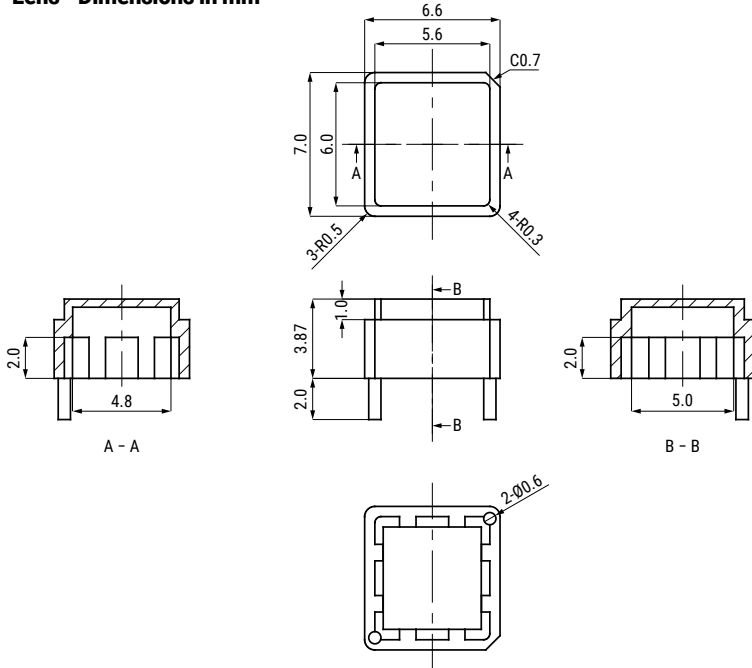

Lens Area with Crack

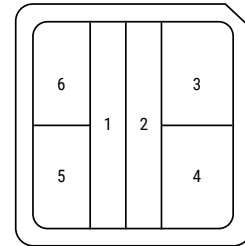

Sensor and Lens Mounting Direction

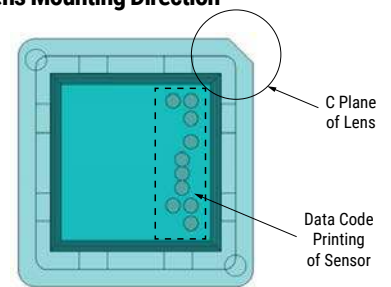

Standard Position of Sensor

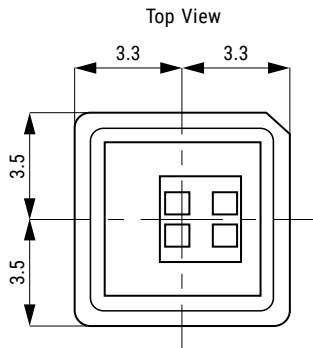

Side View

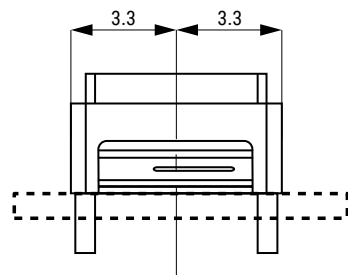

PCB Hole Dimension

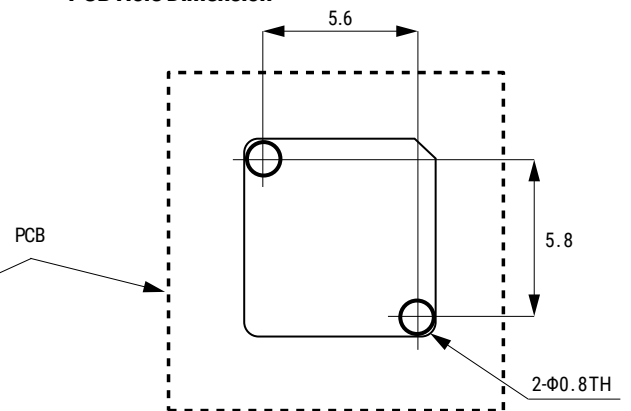

Environmental Compliance

All KEMET Pyroelectric Infrared Sensors are RoHS and REACH Compliant.



Article 33(1) of the REACH Regulation states that manufacturers and importers of articles (products) are required to notify their customers of the presence of any Substances of Very High Concern (SVHC) in their products exceeding 0.1% by weight and provide instructions on safe use of the product.

KEMET Corporation reports regarding the Article 33(1) of REACH Regulation as follows:

1. Applicable Product: Pyroelectric Infrared Sensors (PL series)

2. Report for the content of REACH SVHC list:

The product(s) above contains a substance by more than 0.1wt% per product weight that was published in the 8th update of the REACH SVHC substances (December 19, 2012).

3. Regarding the safety of the pyroelectric infrared sensors (Piezoceramic products):

The Piezoceramic that is used in this product becomes ceramic by sintering powder containing PZT as the main ingredient. It is chemically stable, with minimum risks toward the human body or environment within the intended use of the product. Please note that risks could occur in the case of inhalation or accidental oral uptake of powder ceramics.

4. Technical product information on the multilayer piezoelectric actuators (Piezoceramic products):

The manufacturing technique of the "piezoceramic products" whose main ingredient is Lead Titanium Zirconium Oxide (PZT) has been established, and there is no alternative material that can exhibit superior performance than PZT at this moment. Please note that the piezoceramic is listed as an exempt on RoHS (2011/65/EU) AnnexIII (7c.1).

5. The responsibility of piezoceramic manufacturers:

Piezoceramic manufacturers report information regarding PZT containment in their products to the customers to obey the article 33 of the REACH regulation

Table 1 – Ratings & Part Number Reference
Sensor

Part Number	Supply Voltage (VDC)	Output Voltage ¹ (mVp-p) Minimum	Source Voltage ² (V)	Noise ³ (mVp-p) Maximum	Warm up Time ⁴ (seconds) Maximum
PL-N823-01	2.0 ~ 15.0	550	0.3 ~ 0.9	140	30
PL-Q873-02	2.0 ~ 15.0	550	0.3 ~ 0.9	140	30

Part Number	Field of View (°)	MSL Reflow Temperature ≤ 240°C	Operating Temperature (°C)	Storage Temperature (°C)	Weight (g)
PL-N823-01	Horizontal: ±60° Vertical: ±60°	3	-40°C to +70°C	-40°C to +85°C	0.1
PL-Q873-02	Horizontal: ±60° Vertical: ±60°	3	-40°C to +70°C	-40°C to +85°C	0.1

¹ Difference of temperature with ambient temperature and heat source: 70°C, aperture diameter: $\Phi 10$, 1 Hz and AMP: 26 dB

² $V_d = 5\text{ V}$ and $R_s = 47\text{ k}\Omega$

³ AMP = 72 dB and $R_s = 47\text{ k}\Omega$

⁴ The warm up time is defined by the time needed for the source voltage to reach a rated value after the sensor's power supply has been turned on.

Lens

Part Number	Lens Color	Detection Distance ¹ (m)	Field of View (°)	Operating Temperature (°C)	Storage Temperature (°C)	Weight (g)
PL-001L-N	Natural	5.0	Horizontal: ±37° Vertical: ±28°	-20°C to +60°C	-25°C to +75°C	0.07
PL-001L-BK	Black	3.5	Horizontal: ±37° Vertical: ±28°	-20°C to +60°C	-25°C to +75°C	0.07
PL-001L-W	White	3.5	Horizontal: ±37° Vertical: ±28°	-20°C to +60°C	-25°C to +75°C	0.07

¹ Reference data using SS-430L

Applications

Non-contact Switch

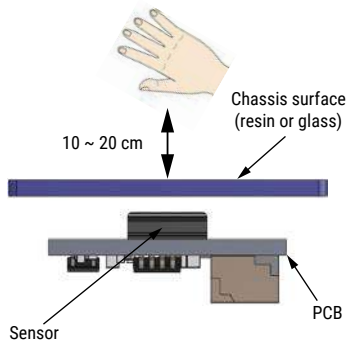

Detecting distance will vary by the chassis material used.

Common Application

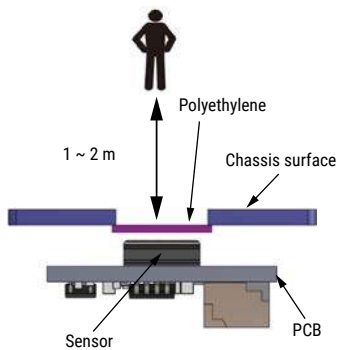

Detecting distance increased to a few meters by using a polyethylene plate.

Part Schematic

Without Lens Type

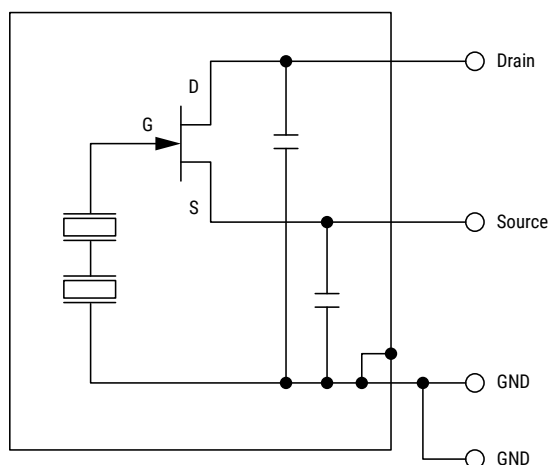

With Lens Type

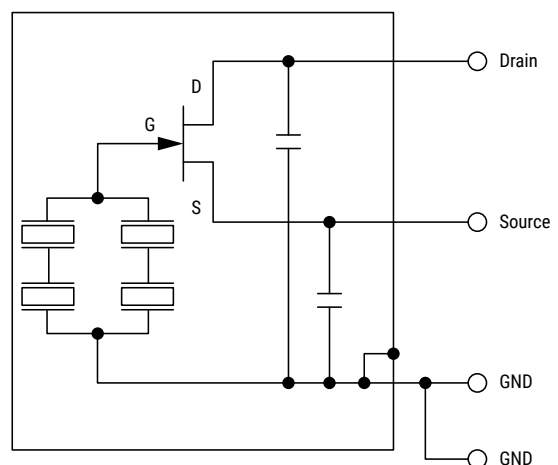

Tape & Reel Packaging Information

Sensor

Series	Packaging Type	Pieces per Reel
PL	Tape & Reel	2,000

Lens

Series	Packaging Type	Pieces per Tray	Pieces per Box
PL	Tray	100	2,000

Taping Specifications

Dimensions of indented square hole plastic tape

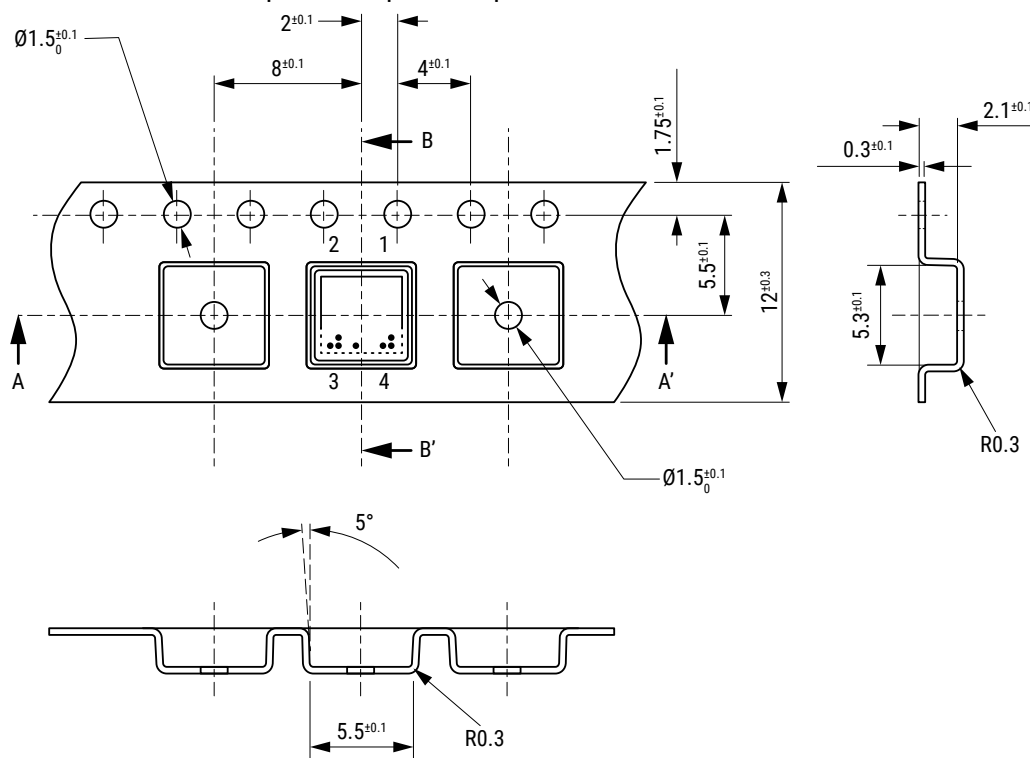

Tape & Reel Packaging Information cont.

Reel Specifications

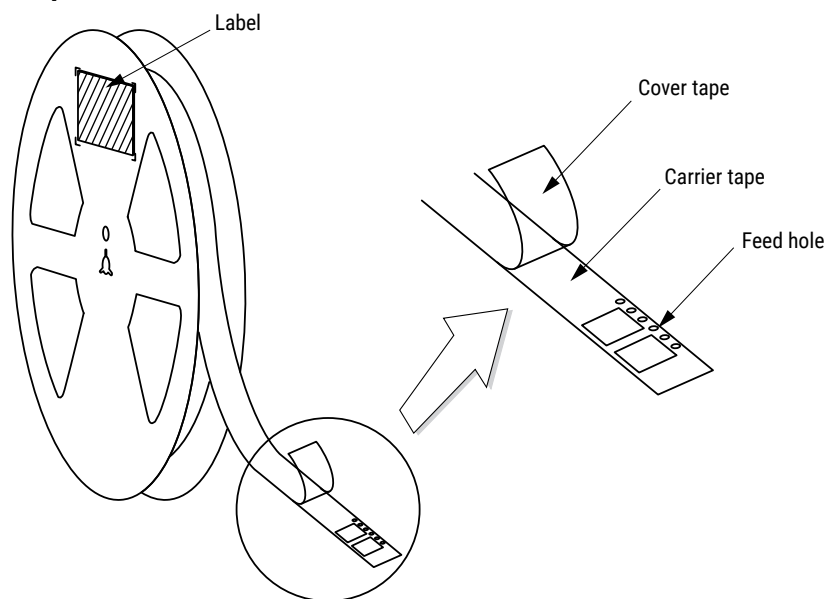

Handling Precautions

Pyroelectric Infrared Sensors should be kept away from indirect and direct sunlight, the headlights of cars, wind, and exposure to strong vibration and strong shock. Do not use in water, alcohol ETA, corrosive gas or undersea breeze. Do not drop or apply any mechanical stress.

Pyroelectric Infrared Sensors should be stored in normal working environments. Do not expose to high temperatures, high humidity, corrosive atmospheres, and avoid long-term storage. KEMET recommends that maximum storage temperature not exceed 25°C and maximum storage humidity not exceed 50% relative humidity. Atmospheres should be free of chlorine and sulfur-bearing compounds.

Temperature fluctuations should be minimized to avoid condensation on the parts. The stock of sensors should be used promptly, preferably within six months of receipt.

KEMET Electronics Corporation Sales Offices

For a complete list of our global sales offices, please visit www.kemet.com/sales.

Disclaimer

All product specifications, statements, information and data (collectively, the "Information") in this datasheet are subject to change. The customer is responsible for checking and verifying the extent to which the Information contained in this publication is applicable to an order at the time the order is placed. All Information given herein is believed to be accurate and reliable, but it is presented without guarantee, warranty, or responsibility of any kind, expressed or implied.

Statements of suitability for certain applications are based on KEMET Electronics Corporation's ("KEMET") knowledge of typical operating conditions for such applications, but are not intended to constitute – and KEMET specifically disclaims – any warranty concerning suitability for a specific customer application or use. The Information is intended for use only by customers who have the requisite experience and capability to determine the correct products for their application. Any technical advice inferred from this Information or otherwise provided by KEMET with reference to the use of KEMET's products is given gratis, and KEMET assumes no obligation or liability for the advice given or results obtained.

Although KEMET designs and manufactures its products to the most stringent quality and safety standards, given the current state of the art, isolated component failures may still occur. Accordingly, customer applications which require a high degree of reliability or safety should employ suitable designs or other safeguards (such as installation of protective circuitry or redundancies) in order to ensure that the failure of an electrical component does not result in a risk of personal injury or property damage.

Although all product-related warnings, cautions and notes must be observed, the customer should not assume that all safety measures are indicated or that other measures may not be required.

When providing KEMET products and technologies contained herein to other countries, the customer must abide by the procedures and provisions stipulated in all applicable export laws and regulations, including without limitation the International Traffic in Arms Regulations (ITAR), the US Export Administration Regulations (EAR) and the Japan Foreign Exchange and Foreign Trade Act.

KEMET is a registered trademark of KEMET Electronics Corporation.