

**KEPCO**

THE POWER SUPPLIER™

800W Programmable Single Output**AE-800 series****Features:**

- Universal AC input / Full range
- Programmable output Voltage (0% ~ 105%)
- Programmable output Current (0% ~ 105%)
- Forced current sharing at parallel operation
- Constant current limit
- Selectable +5V / 0.5A or +9V / 0.3A auxiliary output
- Global control via RS232
- Remote setting multiple PSU via RS232, RS485 & I²C
- Power OK signal
- Remote ON / OFF, Remote sense function
- Protection: OVP, OLP, OTP, Fan failure
- 3 years warranty



MODEL		AE-800-12	AE-800-15	AE-800-24	AE-800-30	AE-800-36	AE-800-48	AE-800-60	
Output	DC Voltage Range	12V	15V	24V	30V	36V	48V	60V	
	Rated Current	66.7A	53.4A	33.5A	26.7A	22.3A	16.7A	13.4A	
	Current Range	0 ~ 66.7A	0 ~ 53.4A	0 ~ 33.5A	0 ~ 26.7A	0 ~ 22.3A	0 ~ 16.7A	0 ~ 13.4A	
	Rated Power	800W	801W	804W	801W	802.8W	801.6W	804W	
	Ripple & Noise (Max.)	Note.2 120mVp-p	150mVp-p	240mVp-p	300mVp-p	360mVp-p	480mVp-p	600mVp-p	
	Voltage Adj. Range	±5.0% Typical adjustment by potentiometer. (VR1)							
	Voltage Tolerance	Note.3 ±2.0%							
	Line Regulation	±1.0%							
	Load Regulation	±1.0%							
	Setup, Rise Time	800ms, 100ms at full load							
Hold Up Time (Typ.)	14ms / 230VAC at full load								
Input	Voltage Range	Note.4 90 ~ 264VAC, 127 ~ 370VDC							
	Frequency Range	47 ~ 63Hz							
	Power Factor (Typ.)	0.95 / 230VAC, 0.98 / 115VAC at full load							
	Efficiency (Typ.)	89%	90%	92%	92%	92%	92%	93%	
	AC Current (Typ.)	9.3A / 100VAC, 3.7A / 240VAC							
	Inrush Current (Typ.)	30A / 115VAC, 60A / 230VAC							
	Leakage Current	< 1.0mA / 240VAC							
Protection	Over Load	105% rated output power, Protection type: Constant current limit							
	Over Voltage	Variable OVP, 120 ± 7% Vout. Refer to VCI VS OVP curve.							
	Over Temperature	85 ±5°C detect on NTC, Protection type: Auto recovery after temperature goes down							
Function	Auxiliary Power	Selectable +5V / 0.5A or +9V / 0.3A auxiliary output							
	Remote ON / OFF Control	By external switch							
	Power OK Signal	Open drain signal low when PSU turns on, Max. sink current: 20mA, Max. drain voltage: 40V.							
	Output Voltage Trim	Adjustment of output voltage is between 0 ~ 105% of rated output							
	Output Current Trim	Adjustment of output current is between 0 ~ 105% of rated output							
	Parallel (Current Sharing)	Note.5	Please refer to page 5						
	Address Setting	Up to 8 units can be set using an address switch (sw1), 0~7							
Environment	Working Temp.	-20 ~ +80°C (Refer to de-rating curve)							
	Working Humidity	20 ~ 90% RH non-condensing							
	Storage Temp. & Humidity	-40 ~ +85°C, 10 ~ 95% RH							
	Temp. Coefficient	±0.02% / °C (0 ~ 50°C)							
	Vibration	10 ~ 500Hz, 2G 10min. / 1cycle, period for 60min. each along X, Y, Z axes Compliance to IEC 68-2-6, IEC 68-2-64							
Safety & EMC	Safety Standards	Certified UL 60950-1; EN 60950-1							
	Withstand Voltage	Note.7	I/P-O/P: 3KVAC (4242VDC), I/P-FG: 1.5KVAC (2121VDC), O/P-FG: 0.5KVAC (707VDC)						
	Isolation Resistance	I/P-O/P, I/P-FG, O/P-FG: 100M Ohms / 500VDC							
	EMI Conduction & Radiation	Certified EN 55022; EN 61204-3; EN 61000-6-3							
	Harmonic Current	Certified EN 61000-3-2; EN 61000-3-3							
	EMS Immunity	Note.6	Certified EN 55024; EN 61204-3; EN 61000-6-1; IEC 61000-4-2, 3, 4, 5, 6, 8, 11						
Others	Cooling	Load and temperature control fan							
	Dimension (WxHxD)	127x41x249 mm / 5.000x1.614x9.803 inch							
	Packing	1.7kg; 6pcs / 11.2kg / 0.55CUFT							

Note

1. All parameters NOT specially mentioned are measured at 230VAC input, rated load and 25°C of ambient temperature.
2. Ripple & noise are measured at 20MHz of bandwidth by using a 12" twisted pair-wire terminated with a 0.1uF & 47uF parallel capacitor.
3. Tolerance: includes setup time tolerance, line regulation and load regulation.
4. De-rating may apply in low input voltage. Please check the de-rating curve for more details.
5. In parallel connection only one unit will operate if the total output load is less than 5% of the rated power.
6. The power supply is considered a component which will be installed into a final equipment. The final equipment must be re-confirmed that it still meets EMC directives.
7. This test done without enclosure.

■ Mechanical Drawings:

Unit: mm / inch

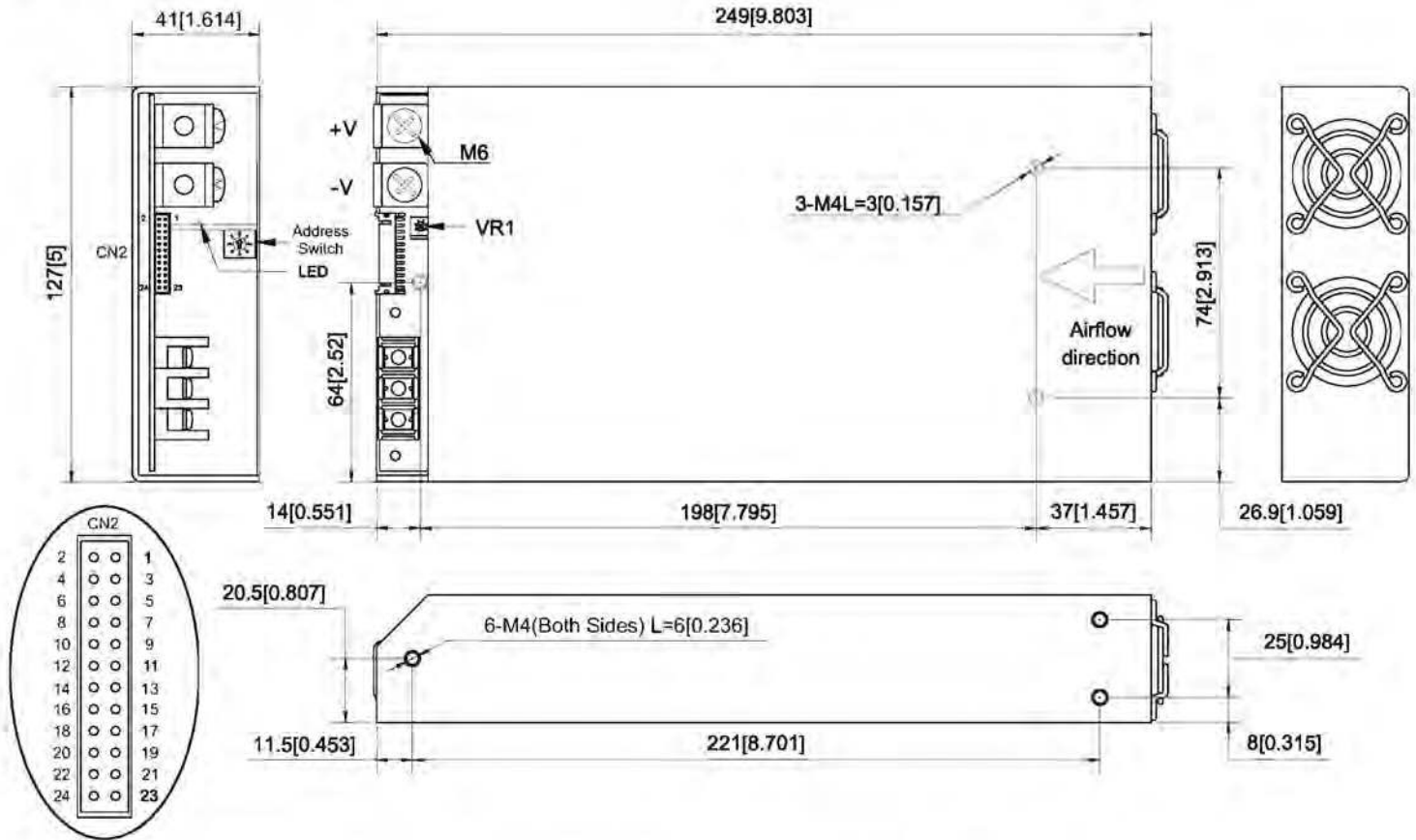

AC Input Terminal Pin No. Assignment

Pin No.	Assignment
1	ACL
2	ACN
3	⊥

Control pin number assignment (CN2): JST S24B-PHDSS or equivalent

Pin No.	Assignment	Pin No.	Assignment	Pin No.	Assignment	Mating Housing / Contact	
1	VS+	9	EN-	17	AUX	JST PHDR-24VS or equivalent	JST SPHD-002T-P0.5 or equivalent
2	VO+	10	GND	18	GND		
3	VS-	11	EN+	19	SCL		
4	VO-	12	AUX	20	SDA		
5	POK	13	ACI	21	AUX		
6	GND	14	GND	22	GND		
7	PAR	15	VCI	23	NC.		
8	VSET	16	GND	24	NC.		

■ CN2 Function Description:

Pin No.	Function	Description	Pin No.	Function	Description
1	VS+	Positive output voltage	13	ACI	I Program
2	VO+	Remote sense (+)	14	GND	Ground
3	VS-	Remote sense (-)	15	VCI	V Program
4	VO-	Negative output voltage	16	GND	Ground
5	POK	Power OK	17	AUX	+5V / 0.5A or +9V / 0.3A Auxiliary power
6	GND	Ground	18	GND	Ground
7	PAR	Parallel operation current share	19	SCL	Serial Clock used in the I ² C interface
8	VSET	Aux output setting	20	SDA	Serial Data used in the I ² C interface
9	EN-	Inhibit ON/OFF (-)	21	AUX	+5V / 0.5A or +9V / 0.3A Auxiliary power
10	GND	Ground	22	GND	Ground
11	EN+	Inhibit ON/OFF (+)	23	NC.	For RS232 Transmission function
12	AUX	+5V / 0.5A or +9V / 0.3A Auxiliary power	24	NC.	For RS232 Receiver function



■ **LED Status:**

LED	LED Signal	Status
Solid(Green)		Power OK (Local mode)
Solid(Orange)		Power OK (Remote mode)
Slow Blink(Green)		Power Standby
Fast Blink(Red)		Over Voltage Protection (OVP)
Solid(Red)		Over Load Protection (OLP)
Slow Blink(Red)		Over Temperature Protection (OTP)
Intermittent Blink(Red)		Fan Failure
Interface Blink(Red)		Power Failure

*Local mode : Use ACI/VCI to control output current and voltage.
Remote mode : Use RS-232 or I²C command to control output current and voltage.

■ **De-rating Curve:**

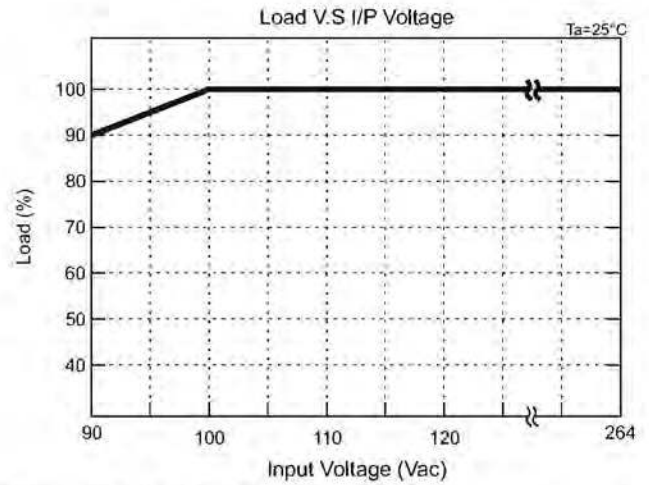
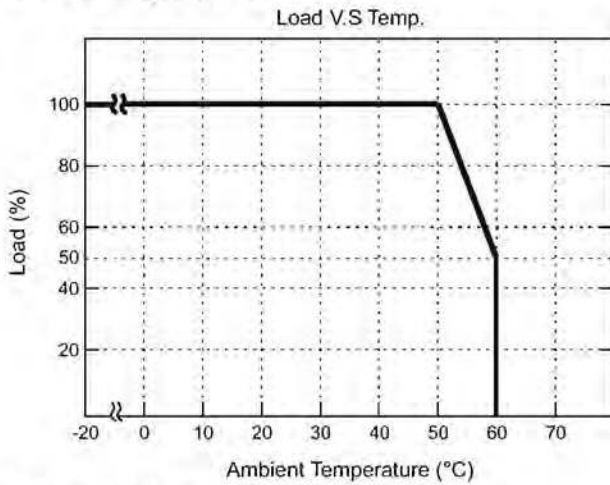

■ **CMD VS Output Curve:**

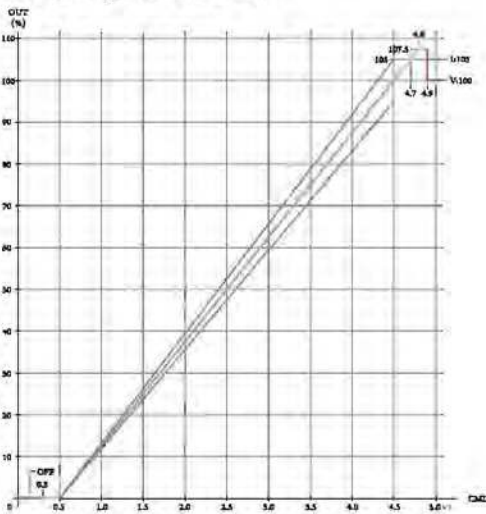

■ **VCI VS OVP Curve:**

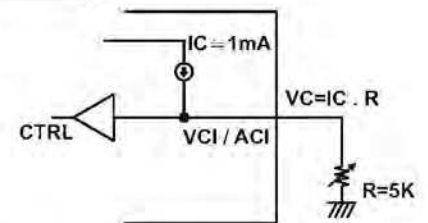
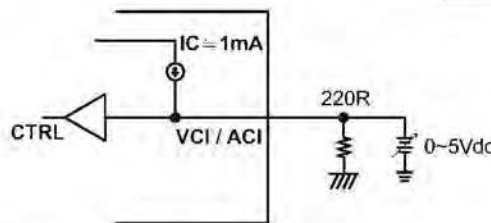
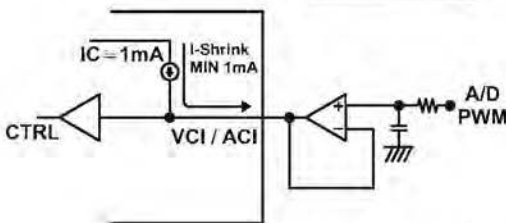
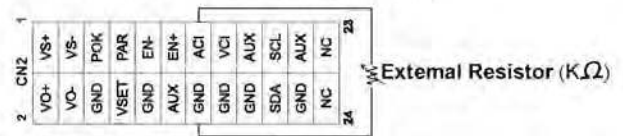
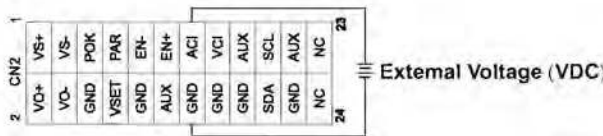
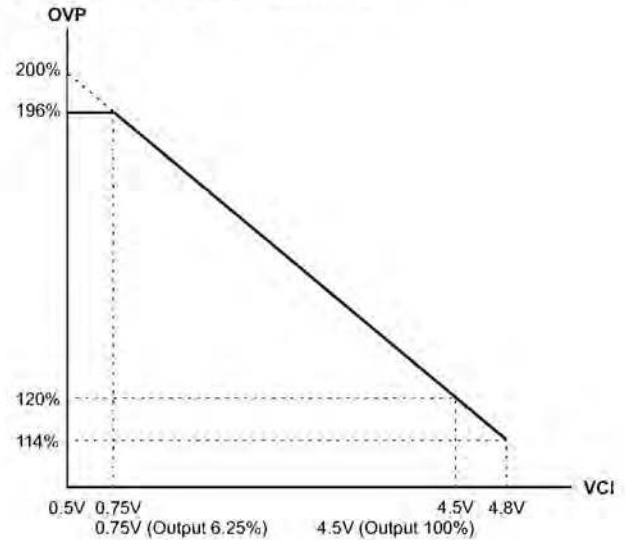

■ Remote ON/OFF:

(A) Default Setting

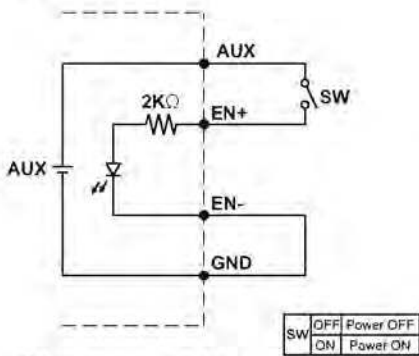

(A) Using internal 5V auxiliary source

(B)

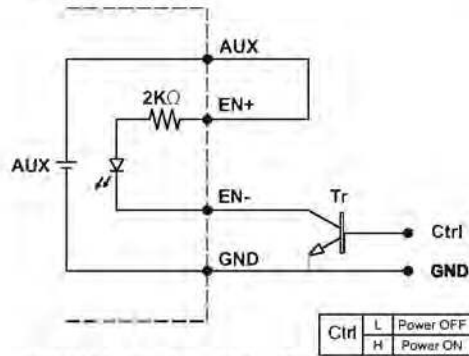

(B) ON / OFF Control by NPN transistor

(C)

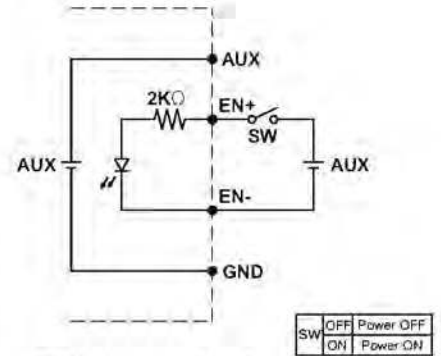

(C) Using external voltage source

■ Power OK Signal:

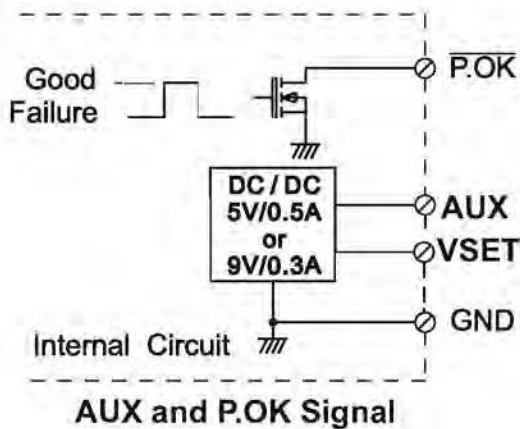

*Place an additional capacitor to have a better performance of auxiliary power operation.

*The grounding of "AUX" power should be connected to "GND" port. If "V-" is connected as Grounding, make sure to short the GND and V- ports.

VSET	Open(Default Setting)	5V
	Short To GND	9V

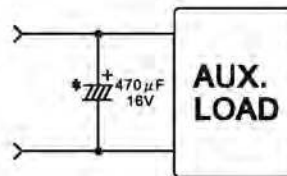

1. Remote Sense

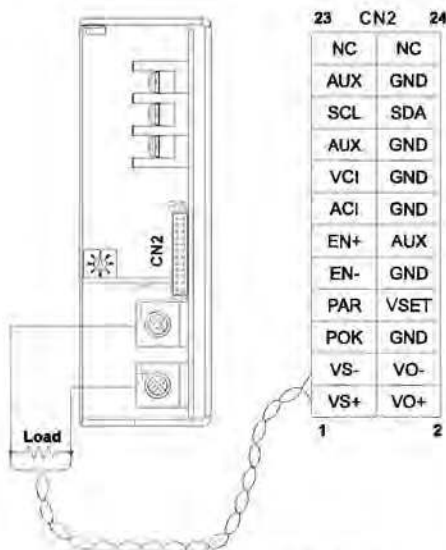

2. Local Sense (Default setting)

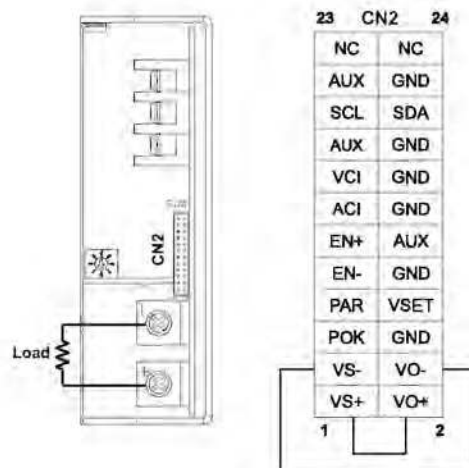



3. Current Sharing with Remote Sensing

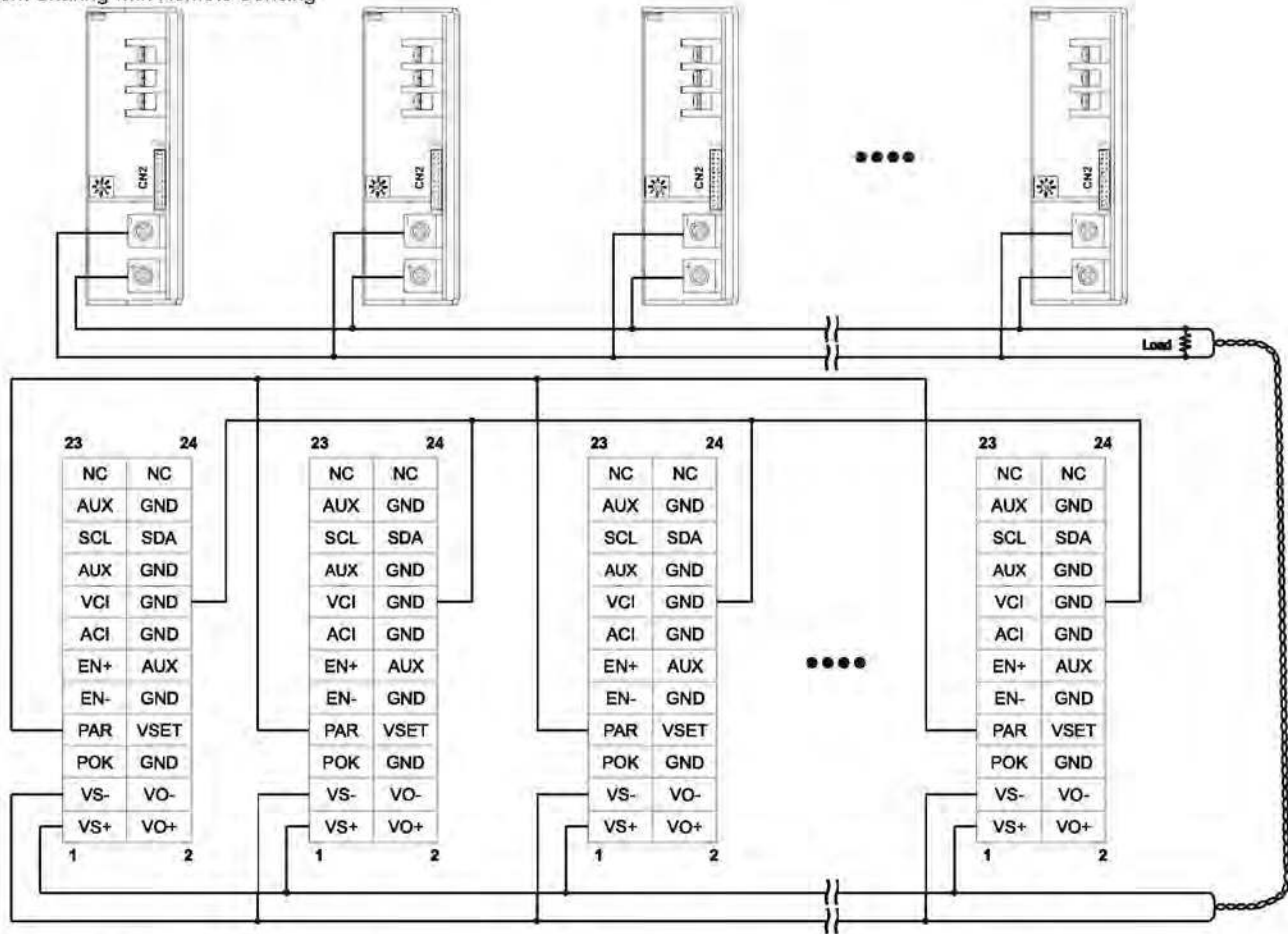

4. Current Sharing with Local Sensing

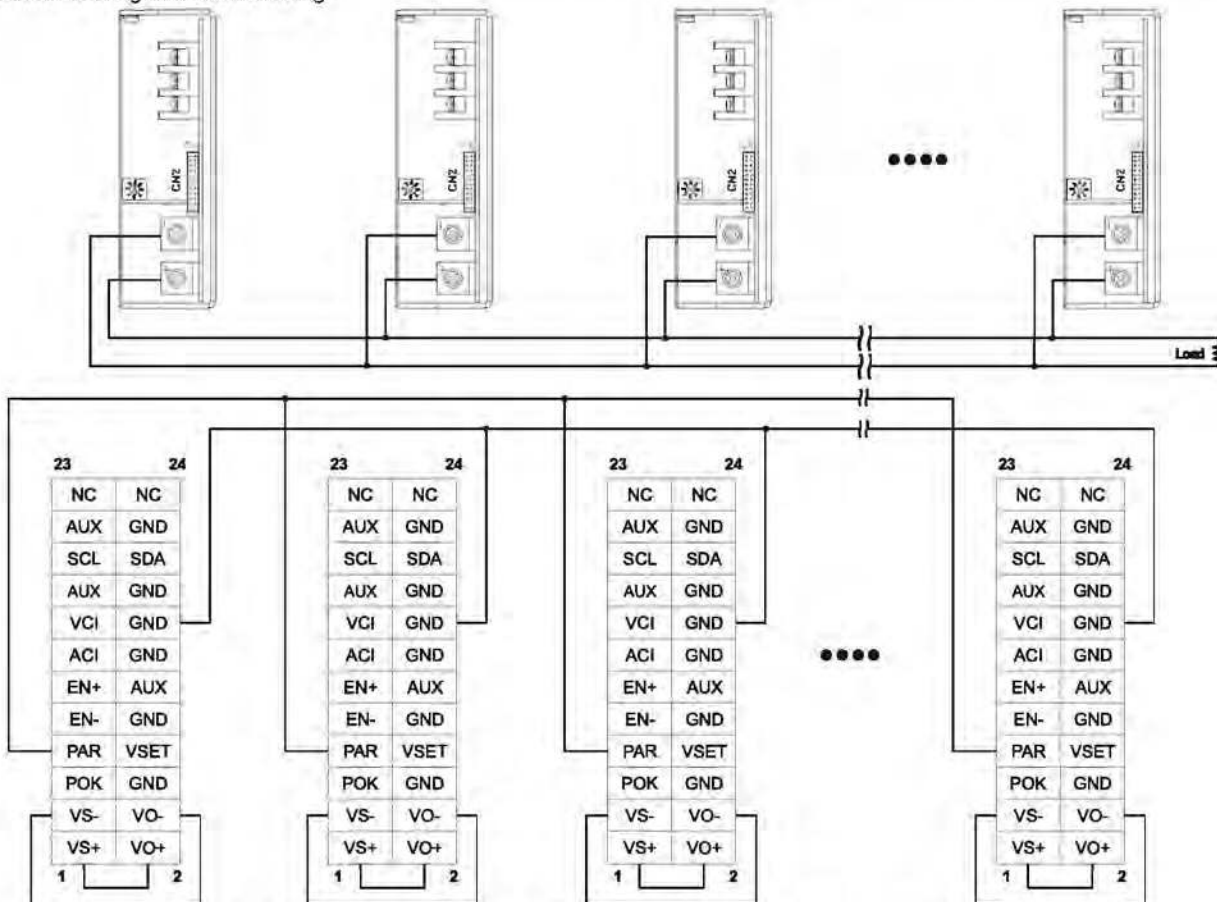

■ **Installation Instruction:**

1. Mounting Directions

1-1 Recommended standard mounting methods:

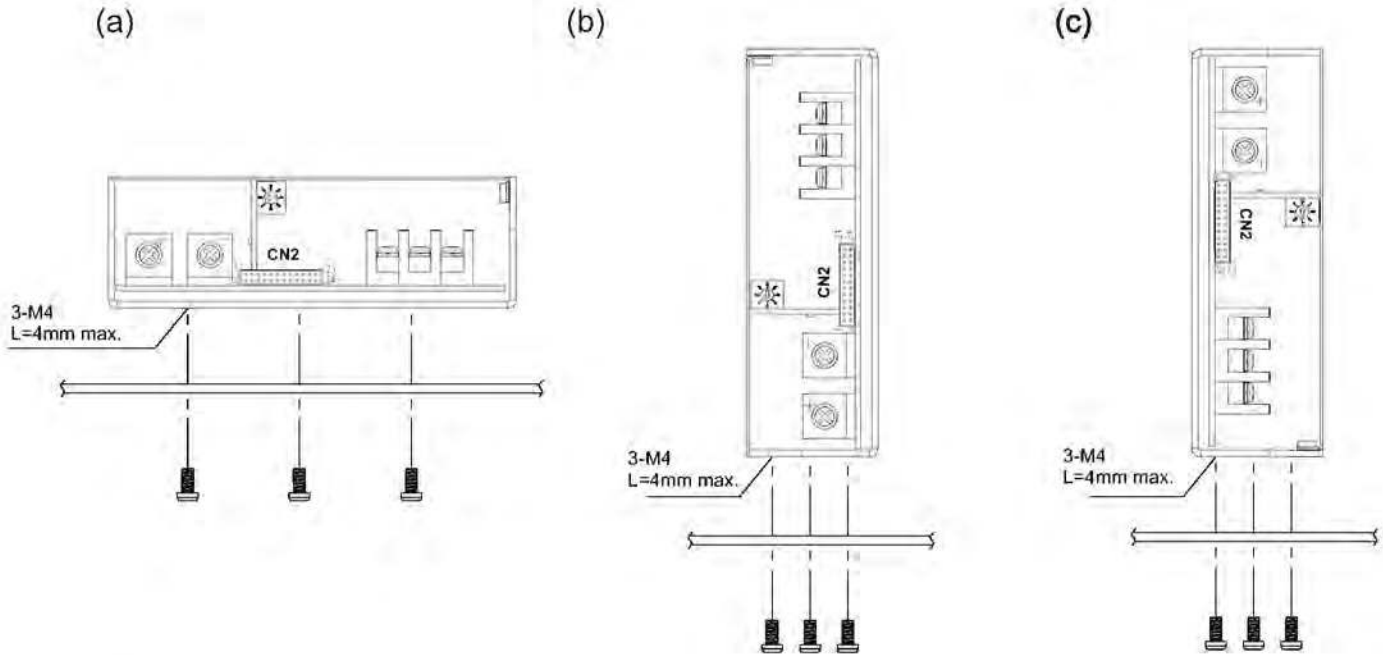

2. Mounting Method

2-1 There are ventilating holes on the front and back side panels, do not obstruct; allow 50mm at least for air flow.

2-2 The Maximum allowable penetration of screw is 4mm. Incomplete threading should not be penetrated.

2-3 Recommended the torque of mounting screw:
 M4 screw: 1.27N · m (13.0kgf · cm)

