

customer manual

SAFETY PRECAUTIONS	READ THIS FIRST !	2
1. INTRODUCTION		3
2. DESCRIPTION		4
2.1. Mechanical Description		4
2.2. Electrical Description		5
3. RECEIVING INSPECTION AND INSTALLATION		6
3.1. Receiving Inspection		6
3.2. Considerations Affecting Machine Placement		6
3.3. Installation		7
3.4. Operation Check		7
4. PREVENTIVE MAINTENANCE		8
4.1. Cleaning		8
4.2. Inspection		8
4.3. Lubrication		8
5. ADJUSTMENTS		9
5.1. Drive Belt Adjustment		9
5.2. Clutch Adjustment		9
5.3. Ram Guide Adjustments		9
5.4. Realignment of Terminator		9
5.5. Shut-Height Adjustment		9
5.6. Ball Screw Adjustment		10
6. PARTS LIST		10
7. AIR FEED ASSEMBLY 690021-3		10
8. REVISION SUMMARY		14



SAFETY PRECAUTIONS AVOID INJURY

Safeguards are designed into this application equipment to protect operators and maintenance personnel from most hazards during equipment operation. However, certain safety precautions must be taken by the operator and repair personnel to avoid personal injury, as well as damage to the equipment. For best results, application equipment must be operated in a dry, dust-free environment. Do not operate equipment in a gaseous or hazardous environment.

Carefully observe the following safety precautions before and during operation of the equipment:

- ALWAYS wear appropriate ear protection.
- ALWAYS wear approved eye protection when operating powered equipment.
- ALWAYS keep guard(s) in place during normal operation.
- ALWAYS insert power plug into a properly grounded receptacle to avoid electrical shock.
- ALWAYS turn off the main power switch and disconnect electrical cord from the power source when performing maintenance on the equipment.
- NEVER wear loose clothing or jewelry that may catch in moving parts of the application equipment.
- NEVER insert hands into installed application equipment.
- NEVER alter, modify, or misuse the application equipment.

TOOLING ASSISTANCE CENTER

CALL TOLL FREE 1-800-722-1111 (CONTINENTAL UNITED STATES AND PUERTO RICO ONLY)

The **Tooling Assistance Center** offers a means of providing technical assistance when required.

In addition, Field Service Engineers are available to provide assistance in the adjustment or repair of the application equipment when problems arise which your maintenance personnel are unable to correct.

INFORMATION REQUIRED WHEN CONTACTING THE TOOLING ASSISTANCE CENTER

When calling the Tooling Assistance Center regarding service to equipment, it is suggested that a person familiar with the device be present with a copy of the manual (and drawings) to receive instructions. Many difficulties can be avoided in this manner.

When calling the Tooling Assistance Center, be ready with the following information:

1. Customer name
2. Customer address
3. Person to contact (name, title, telephone number, and extension)
4. Person calling
5. Equipment number (and serial number if applicable)
6. Product part number (and serial number if applicable)
7. Urgency of request
8. Nature of problem
9. Description of inoperative component(s)
10. Additional information/comments that may be helpful

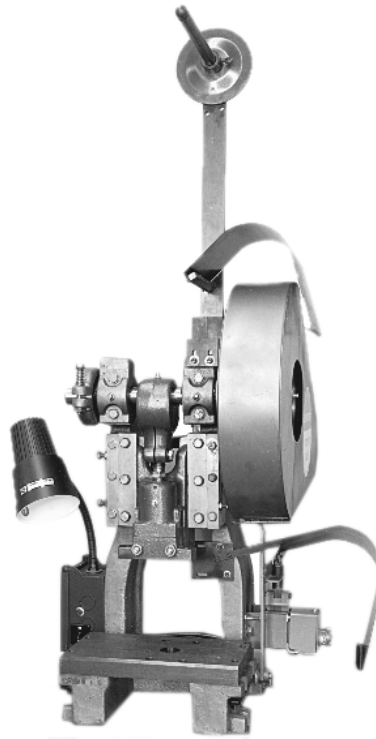

Figure 1

1. INTRODUCTION

The Five-Ton Terminator is a modified version of the BENCHMASTER* Machine, manufactured by the BENCHMASTER Manufacturing Company, 1835 West Rosecrane Avenue, Gardena, California, 90249. The basic terminator has been modified by the manufacturer to meet the requirements of Tyco Electronics. In addition, Tyco Electronics has installed a reel bracket assembly, motor, bolster plate, and other components to adapt the terminator to standard type applicators that require in excess of 5000 pounds force.

Read the following instructions carefully before operating the unit. The performance of the unit will depend largely upon information contained in this customer manual and operator training and skill.

When reading this manual, pay particular attention to **DANGER, CAUTION, NOTE** statements.

DANGER *Denotes an imminent hazard which may result in moderate or severe injury.*



CAUTION *Denotes a condition which may result in product or equipment damage.*



NOTE *Highlights special or important information.*



*Trademark of BENCHMASTER Mfg. Co. Gardena, CA

NOTE

Numerical units are in millimeters [with U.S. customary units in brackets].

**2. DESCRIPTION****2.1. Mechanical Description**

With the electrical power ON, the motor runs continuously, thus driving the flywheel in a counterclockwise direction (as viewed from the flywheel-side of the terminator). When the solenoid is energized, it pulls the clutch wedge, through mechanical linkage, to release the clutch dog. In doing so, the clutch dog is forced toward the flywheel by spring tension to engage in one of the notches in the flywheel hub as it passes. This provides a mechanical coupling between the revolving flywheel and the crankshaft. The crankshaft, when coupled with the flywheel makes one revolution to provide the driving force to the ram and clamp assembly on the downward stroke of the and return it to the raised position by the eccentric in the crankshaft. During the revolution of the crankshaft, the clutch wedge is unlatched from the mechanical linkage to the solenoid by the single trip screw and it returns to the original position. As the crankshaft completes one revolution, the clutch dog is cammed away from the flywheel by the released clutch wedge to break the coupling and stop the rotation when the clutch dog contacts the stop block on the wedge. The drag of the friction brake assembly prevents crankshaft rebounds. Another cycle of the terminator cannot be performed until the solenoid is de-energized, then re-energized to release the clutch wedge.

The designed stroke of the terminator is 1 1/4 inches, which is required for standard type applicators. The shut-height is adjusted by turning the ball screw IN or OUT of the connecting rod (conrod) after loosening the locking screw. The shut-height is determined by the crimp height required for the size wire and the type of terminal being used.

press

The air valve mounted on the front of the terminator (when applicable) is mechanically actuated "open" and "closed" by an adapter on the applicator ram post during each cycle of the terminator. Refer to the applicable applicator instructions supplied with the applicator, for further information pertaining to air pressure required and the use of this valve.

The crank, attached to the front of the terminator, is used to manually turn the terminator through a cycle of operation with an applicator installed. The terminator shroud has been installed to protect operating personnel during power operation.

2.2. Electrical Description (Figure 2)

With the electrical plug inserted into a 115 v outlet, power is applied to the main switch S2 and to the light switch S1. Turning the light switch (on) illuminates the work light DS1. Placing the main switch to ON applies power to motor B1 and the foot switch S3 as indicated by the panel light DS2. When the foot switch is depressed, the clutch solenoid L1 is energized and remains energized until the foot switch is released.

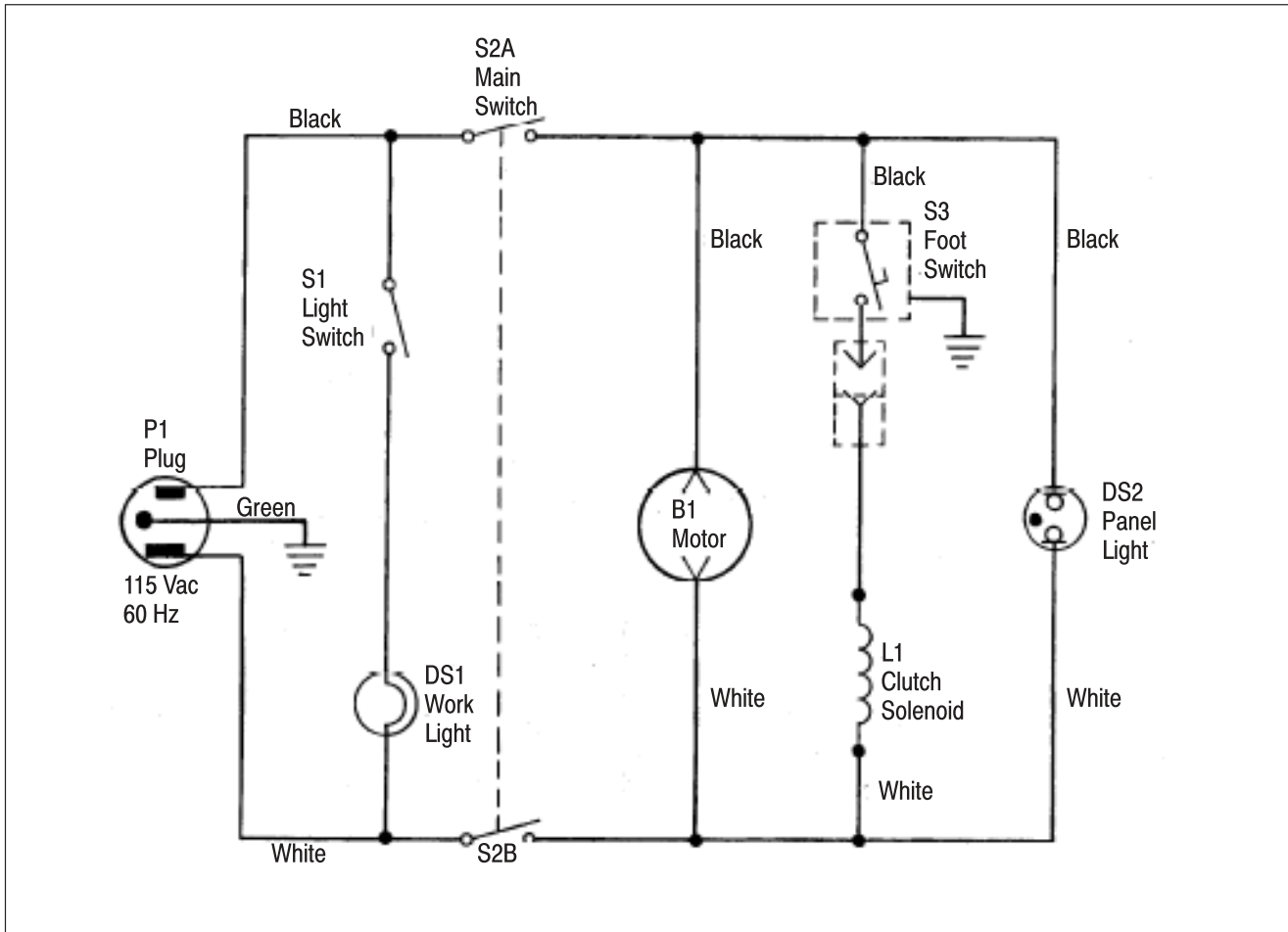

Figure 2

3. RECEIVING INSPECTION AND INSTALLATION

3.1. Receiving Inspection

The machine is thoroughly inspected during and after assembly. Before it is shipped, a final series of tests and inspections are made to ensure proper functioning. Still, the following inspection should be performed as a safeguard against problems during shipment.

1. Carefully uncrate the machine and place it on a sturdy bench where there is enough light to permit a careful examination.
2. Remove the cover, and thoroughly inspect the entire machine for evidence of damage that may have occurred during transit. If the machine is damaged, file a claim against the carrier and notify Tyco Electronics immediately.
3. Check all components and parts to be certain they are secure.
4. Check wiring for loose connections and for frayed or broken wire and insulation.
5. Check all air lines for evidence of loose connections or damage.

NOTE

*It is important that this manual, other documents with the machine (eg, drawings, parts lists, applicator instructions, etc) and any enclosed product samples **remain with the machine** for the benefit of personnel responsible for installation, operation, and maintenance.*

3.2. Considerations Affecting Machine Placement

Proper location of the machine in relation to the operator is essential to both safety and efficiency. Studies have repeatedly shown that fatigue will be reduced and efficiency increased if particular attention is paid to the bench, the operator's chair, and the placement of the foot valve if one is used.

A. Bench (When Applicable)

A sturdy bench 711 to 762 mm [28 to 30 in.] high aids comfort by allowing the operator's feet to rest on the floor and the weight and leg position to be easily shifted. The bench should have rubber mounts to reduce noise. The open area under the bench should allow the chair to slide far enough in for the operator's back to be straight and supported by the back rest.

B. Machine Location on Bench (When Applicable)

The machine should be located near the front of the bench, and the machine work area (the area where the product is applied) should be 152 to 203 mm [6 to 8 in.] from the front edge. Access to the back of the machine must be provided for maintenance purposes in most cases.

C. Operator's Chair (When Applicable)

The operator's chair should swivel, and the seat and back rest should be padded and independently adjustable. The back rest should be large enough to support the back both above and below the waist.

In use, the chair should be far enough under the bench so that the operator's back is straight and supported by the back rest.

D. Foot Switch (When Used)

When the operator is correctly positioned in front of the machine, the foot should rest on the valve comfortably and easily. The valve should be placed on a rubber mat; this allows it to be movable and permits the operator to shift positions to minimize fatigue, while at the same time the mat prevents the valve from sliding unintentionally.

The preference for locating the switch varies among operators. Some like the valve located so that their foot rests on the valve when their legs are in the natural sitting position (calf perpendicular to the floor). Others prefer it slightly in front of the natural position. The important thing is that the foot be about 90° to the calf when resting on the valve. Those who prefer the valve slightly forward may require a wedge-shaped block placed under it.

Figure 3 shows proper location and position. Figure 4 shows a typical layout for the efficient handling of materials.



Figure 3 shows the physical considerations as recommended, and the operator in a desirable position. Note that the chair height and back rest are properly adjusted, and that the chair is properly located in respect to the bench. Thus, the operator's back is straight, and supported by the chair. Note also that the operator's upper arms are in a direct line with the torso.

Figure 3

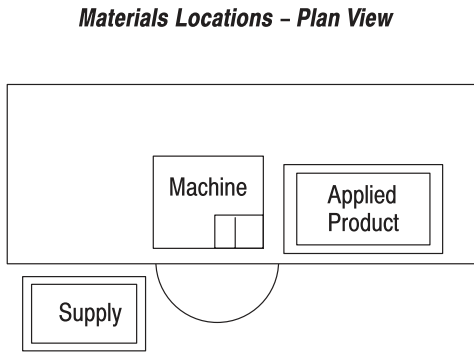

The plan view, Figure 4, identifies typical locations for "supply" and "applied product," and serves as an aid in visualizing the convenience in materials handling afforded by proper setup and correct operator positioning.

Figure 4

3.3. Installation

It is recommended that the terminator be installed in a well-lit area at a convenient height for the operator. Because of the weight, a sturdy bench or similar structure is required and once the exact position is established, the terminator should be anchored to prevent movement.



DO NOT connect the terminator to the electrical outlet until specified. Accidental operation of the unit could cause damage to the terminator, as well as personal injury.

THOROUGHLY clean the press of any dust or grit that may have collected during shipping. Following cleaning, IMMEDIATELY lubricate the terminator as described in Paragraph 4.3. No element of the terminator operation is more important than correct and adequate lubrication applied immediately upon receipt of the terminator. Although the terminator is "run-in" at the factory prior to shipment, a break-in will not occur until after several hours of operation. During this period, frequent and generous lubrication will assure long and satisfactory service. Failure to supply lubricant will cause almost instant galling and possible irreparable damage to precision bearings and sliding surfaces. Wipe off all excess lubricants.



If a rust preventing coating is evident, clean it off with kerosene or solvent. Its removal also removes grease and oil supplied to the terminator prior to shipment. LUBRICATE THE TERMINATOR NOW.

3.4. Operation Check

1. Manually actuate the solenoid to engage the clutch dog, then rotate the flywheel by hand, one complete revolution *COUNTERCLOCKWISE* to make sure the ram cycles fully throughout its stroke without obstruction. Should an applicator be installed on the terminator, use **EXTREME CAUTION** to prevent damage to tooling in the event it should bottom. If necessary, adjust the shut-height as described in Paragraph 5.5 by turning the ball screw UP.



Before performing the next step, MAKE CERTAIN the clutch is disengaged and the solenoid is in the de-energized position.

2. Check the direction of motor rotation by inserting the electrical plug and placing the switch to "on." The correct direction of rotation is indicated by an arrow on the flywheel. Should the direction of rotation be incorrect, make the necessary wiring corrections within the motor.

3. With the motor rotating correctly, check the terminator operation through several cycles by depressing the footswitch. Again, if an applicator is installed in the terminator, perform several test cycles using the correct terminals and wire size to be run in production and check that the crimp height is within tolerance as specified on the applicator parts list.
4. Should the crimp height be incorrect, adjust the shut-height as described in Paragraph 5.5. The crimp height should be checked periodically during production operation to be assured it is within tolerance.

NOTE

FOR PRODUCTION OPERATION INFORMATION, REFER TO THE BENCHMASTER MACHINE MANUAL SHIPPED WITH THE MACHINE.

4. PREVENTIVE MAINTENANCE

Preventive maintenance is cleaning, inspecting, and lubricating the machine to keep it in continuous operation. It is suggested that a regular maintenance program be established and followed to eliminate the cost of unnecessary repairs. For applicators and special applications of the machine, refer to the publications supplied with them.

DANGER

To avoid personal injury, ALWAYS disconnect electrical and air supply before performing preventive maintenance.

4.1. Cleaning

1. Using a CLEAN, dry cloth, wipe the entire machine to remove any dust or other foreign matter from accessible areas.
2. Using a solvent or similar cleaning fluid, remove any oil or grease from machine.
3. Using an air hose, blow out any chips and metal particles that may be in the machine, especially in the work area.

DANGER

Compressed air used for cleaning must be reduced to less than 206.8 kPa [30 psij], and effective chip guarding and personal protective equipment (including eye protection) must be used.

4.2. Inspection

1. Inspect entire machine for loose components and hardware.
2. Inspect electrical wiring for loose connections, chafing, and broken wires or insulation.
3. Inspect moving parts for evidence of excessive wear.
4. Inspect machine for proper lubrication. If necessary, lubricate in accordance with Paragraph 4.3.

4.3. Lubrication

1. For all bearings and sliding surfaces, use a thin moly-base machine grease in all grease fittings. Apply by pressure gun until the grease exudes from between the surfaces. This will assure that the grease cavities are filling properly.

NOTE

Lubricate the terminator TWICE daily under continuous operation. This is twice per eight hour shift.

2. Oil all linkage units with a heavy viscosity oil.
3. Oil the brake assembly with two or three drops of light oil to prevent squealing.

4. Oil the ball screw with a heavy viscosity oil.
5. Oil the clutch dog with a heavy viscosity oil.

NOTE

GREASE on the clutch dog will cause sticking and consequent malfunctioning.



5. ADJUSTMENTS

The following adjustments may be required by inspection and/or following the replacement of parts in the terminator.

DANGER

To avoid personal injury, be sure the terminator is not connected to electrical power during adjustments (unless otherwise specified).



5.1. Drive Belt Adjustment

Adjust the motor bracket to obtain sufficient tension on the V-belt to drive the flywheel. Over-tightening the V-belt may result in damage to the motor.

NOTE

REFER TO THE BENCHMARKER INSTRUCTIONS FOR PARTS REFERENCE.



5.2. Clutch Adjustment

Before leaving the factory, the clutch of the terminator was thoroughly inspected and adjusted. Until such time as wear is present, the clutch adjustment should *not* be necessary. The clutch wedge should have 0.127mm to 0.381mm [.005 to .015 inch] clearance from the clutch collar assembly. This adjustment can be made by loosening the two jam nuts, then turning the two adjusting screws. After adjustment is obtained, tighten the jam nuts to secure the screws.

5.3. Ram Guide Adjustments

Should any adjustment be required after long service, check the right ram guide (facing the terminator) for alignment as described in Paragraph 5.4. Take up the side play with the left ram guide, allowing 0.0254mm [.001 inch] maximum clearance on one side of the ram and clamp assembly. This is accomplished by slightly loosening three screws, then loosening the two jam nuts and turning the two adjusting screws in the left ram guide adjuster until the correct clearance is obtained. Tighten the three screws to secure the left ram guide, then tighten the two jam nuts to secure two screws in the left ram guide adjuster.

This will retain original factory accuracy and alignment since the right ram guide is used for locating purposes during manufacturing and the bolster plate is squared (90 degrees) to this edge.

5.4. Realignment of the Terminator

This procedure should not be required unless it is necessary to remove or replace the right ram guide (which is considered the solid side) to realign ram travel at right angles to the bolster plate the right side should be squared first. This is accomplished by inserting a ground bar in the ram and adjusting the right ram guide until square with the bolster plate.

To adjust the right ram guide, make sure the three screws in the right ram adjuster are tight. Slightly loosen the three screws securing the right ram guide, then loosen two jam nuts and turn the two screws in the right ram guide adjuster as necessary until the ram is square with the bolster plate.

Adjust the left ram guide to obtain .001 in clearance on one side of the ram as described in Paragraph 5.3.

5.5. Shut-Height Adjustment

The shut-height is adjusted by rotating the ball screw in the conrod. This is determined by the crimp height required for the terminal and and size wire to be used in the applicator installed in the terminator. For the correct crimp height, refer to the parts list supplied with the applicator.

To adjust the shut-height, loosen the screw in the conrod and turn the ball screw up or down as required, then re-tighten the screw to secure it. **Do not** over-tighten the screw, as it is not necessary and may set up strains causing cracks and possible damage when under operation.

5.6. Ball Screw Adjustment

If, after long service, it is necessary to remove the play of the ball screw in the ram and clamp the assembly, tighten the ball screw retainer until the ball screw is locked. Then back off the retainer approximately 1/4 turn.

6. PARTS LIST

Refer to the BENCHMASTER documentation shipped with the machine for parts list information.

NOTE



When ordering a part that has a BENCHMASTER part number from Tyco Electronics, be sure to specify that it is for a BENCHMASTER terminator. This will prevent confusion with the Tyco Electronics numbering system.

7. AIR FEED ASSEMBLY 690021-3

7.1. Introduction

The air feed assembly is an option for the press, and is required for various standard type applicators to feed the terminal strip into the “target area” during each cycle of the terminator. When installed, it is connected to the air on-off valve on the terminator for operation. Refer to the applicator instructions supplied with the applicator for further information pertaining to the applicator, and the mounting of the air-feed assembly. The air feed assemblies are supplied with the applicators, but are included in this manual to cover adjustments and the replacement of parts.

7.2. Functional Description

Air pressure is supplied to the cylinder of the air-feed assembly by the air feed valve, through the flow control valve and the quick-exhaust valve, to the extension port when the terminator is in the rest position. On the downward stroke of the ram, the air supply is shut off and the piston of the cylinder is retracted by spring pressure. for the feed finger to pick up the next feed point in the terminal strip. On the upward stroke of the ram, air pressure is again applied to the extension side which advances the feed finger, and locates the next terminal in the “target area.” This is referred to as, “pre-feed” type.

The cylinder is mounted on a feed adjusting bracket which permits horizontal adjustment of the cylinder by the feed adjusting screw, and angle adjustment by means of the swivel screw. The maximum length of the cylinder is stroke is 2 inches. For a desired length less than the minimum, adjustment is by means of the piston positioner on the cylinder shaft. The desired length is slightly greater than one feed length of the terminal strip which allows for a slight overtravel of the feed finger when retracted. This assures positive feeding of the strip.

7.3. Adjustments

The following adjustments may be necessary to maintain normal normal operation of the air feed assembly, or following the replacement of parts.

A. Flow Control Valve Adjustment (see Figure 5)

To adjust the flow control valve, it is necessary to have an applicator installed in the terminator and loaded with terminal strip. Withe the air supply connected, hand-cycle the terminator through several complete cycles. During cycling, check the speed of the feed stroke — keeping in mind that the speed of the feed stroke is basically the same as, whether hand-cycled or operated under power. The feed stroke should be slow enough to prevent overfeeding or deformation of terminals.

NOTE



Note that a feed stroke that is too slow will hinder production by the operator.

If necessary, adjust as follows:

1. Loosen the locknut on the flow control valve.

2. To decrease speed, turn the adjustment screw clockwise; to increase the speed, turn the adjustment screw counterclockwise.
3. After adjustment, tighten the locknut, then disconnect the air supply.

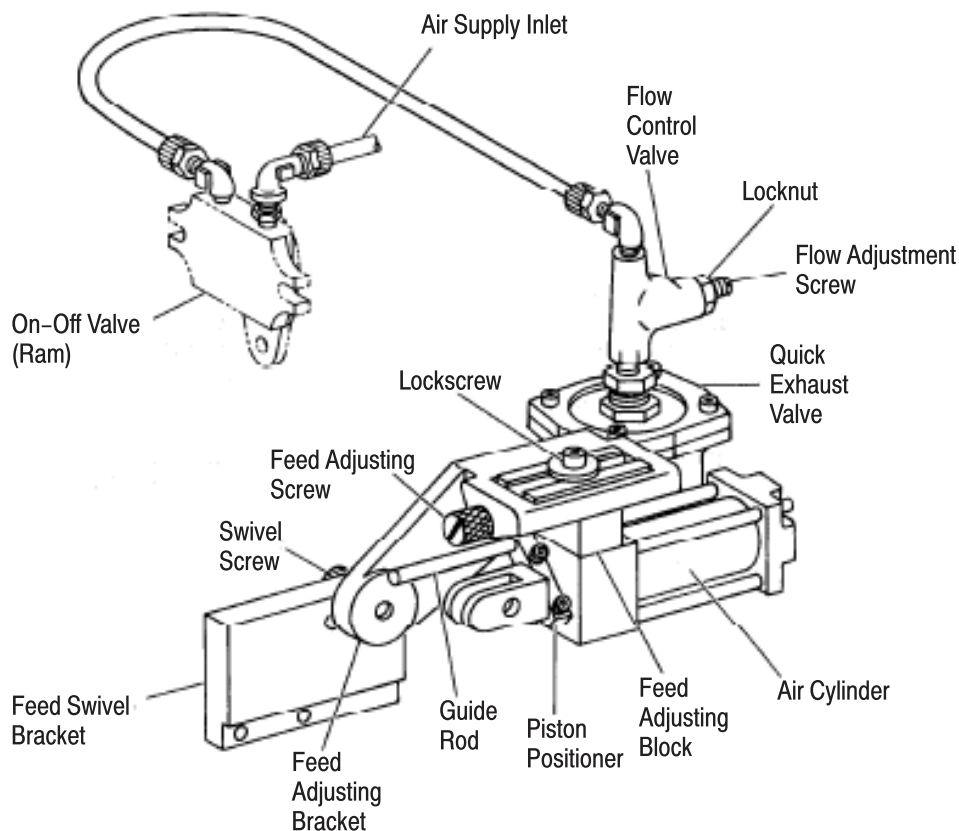

Figure 5

B. Feed Cylinder Adjustment (see Figure 5)

1. Make certain the terminator is at the top dead center (tdc). If necessary, hand-cycle the terminator to obtain this condition.
2. Install applicator and feed finger as described in the applicator instructions (supplied with the applicator).
3. Load the terminal strip into the applicator in accordance with the applicator instructions.
4. Check the angle of the feed adjusting bracket. It should be positioned so the cylinder and feed finger are in a straight line. If necessary, loosen the swivel screw and raise or lower the cylinder to obtain the correct position. Tighten the swivel screw.
5. If applicable, check the mounting screws in the feed swivel bracket. They should be centered in the slotted holes. If they are not centered, loosen the screws and adjust the bracket position, then tighten the screws.
6. Connect the air supply. Then check that the lead terminal is centered over the anvil.
7. Be sure the feed finger is against the feed point in the terminal strip for the lead terminal. If not loosen the the lock screw securing the feed adjusting block. Then turn the feed adjusting screw, as required until the feed finger is against the feed point and the lead terminal remains centered over the the anvil. Tighten the lock screw to secure the adjustment.
8. Check the position of the piston positioner. It must be one feed length (as specified on the applicator parts list) plus enough overtravel on the feed finger retract stroke to drop into the next feed point. If not,

loosen two screws securing it to the piston rod, and slide in the required direction to obtain this dimension. Then tighten the screws to secure.

9. Hand-cycle the terminator until the feed finger is fully retracted. A slight over-travel should exist, but should not be excessive. If necessary, repeat Step 8.

10. Continue to hand-cycle the terminator to return it to the "rest" position. If necessary, adjust the feed finger tension as described in the applicable applicator instructions.

11. Cycle the terminator under power several times to check for proper adjustment. If necessary, repeat the preceding steps, as required.

12. With the adjustment completed, disconnect air supply.

7.4. Repair and Replacement (Figure 6)

There are no special procedure required for replacement of parts in the air feed assembly. Refer to the included drawings and parts list for detail parts identification. In the event it is necessary to repair the quick-exhaust valve, install the valve repair kit No. 22989-1 (diaphragm and gasket) as shown in Figure 6. Should it be necessary to replace the air feed cylinder, use the replacement parts as shown in Figure

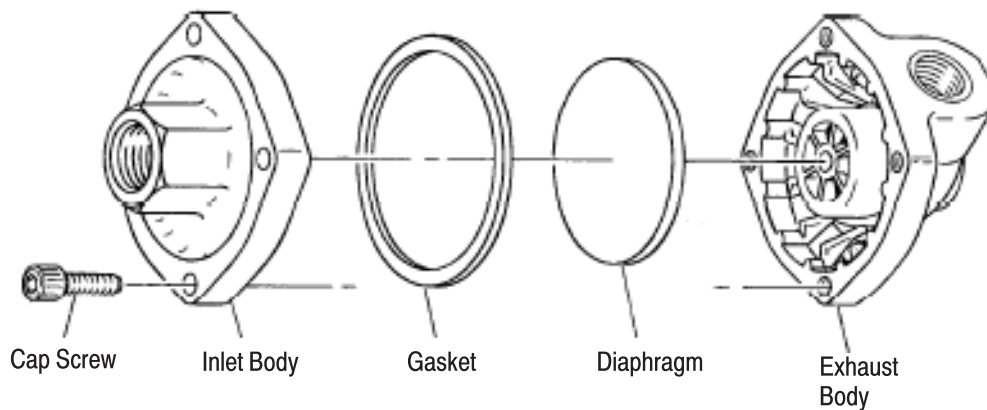

Figure 6

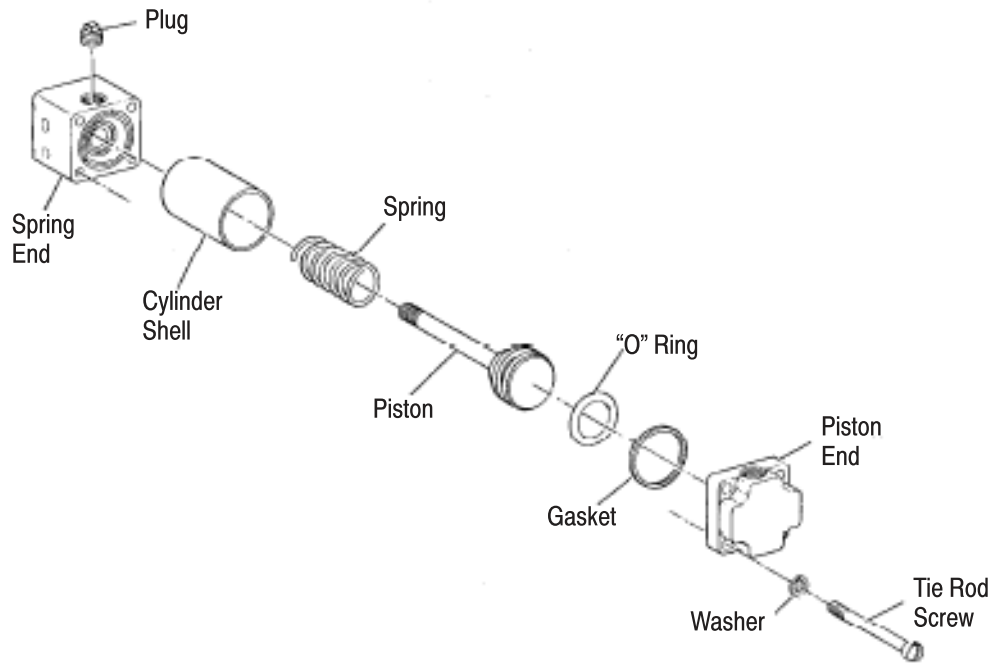

Figure 7

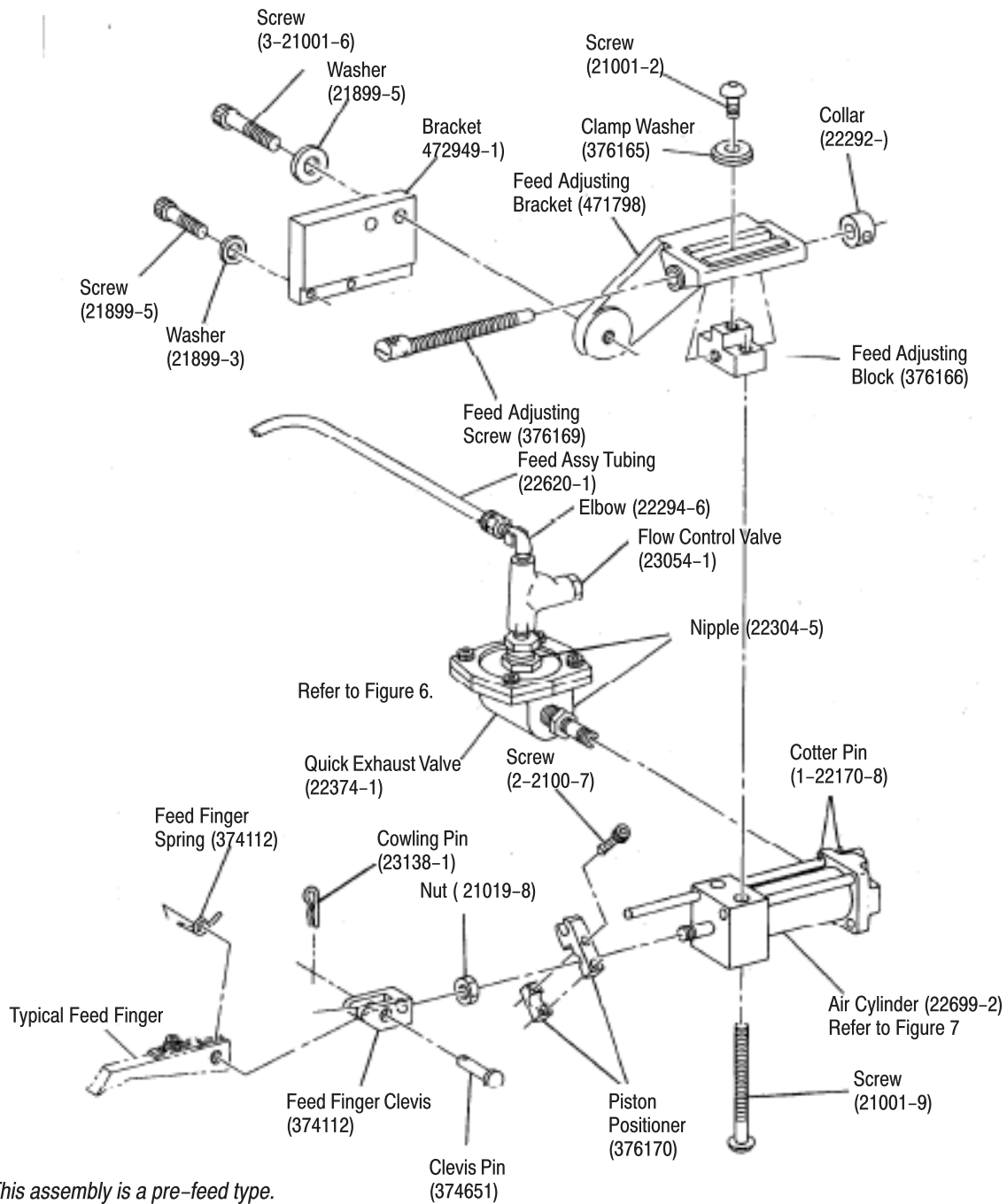

Figure 8

8. REVISION SUMMARY

Since the previous release, the BENCHMARKER parts lists have been removed, and the format was updated to the current corporate requirements.