

SIGN	DATE	DESCRIPTION	APPROVER
△	1/29'07	Soldering temperature changed from 245° to 250°	Tony
△	4/17'09	The design is changed	Jacke
△	4/17'09	Add the tolerance table	Jacke
△	4/17'09	The operating temperature is changed	Jacke
△	2010.01.22	The demension is changed from 1.60mm to 1.10mm	Jacke
△	2010.01.22	The demension is changed from 0.40mm to 0.20~0.30mm	Jacke
△	2010.03.31	The material is changed from Brass to Copper	Jacke
△	04/23'12	Flange nut is changed	Chen Bo
△	04/23'12	The demension is changed from 1.50mm to 1.00mm	Chen Bo
△	04/23'12	The Dimension Dim C is added	Chen Bo
△	04/23'12	The demension is changed from 7.1mm to 7.3mm	Chen Bo

THIS IS CAD DRAWING, DO NOT REVISE MANUALLY!!!

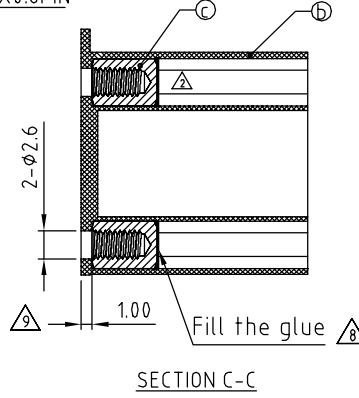
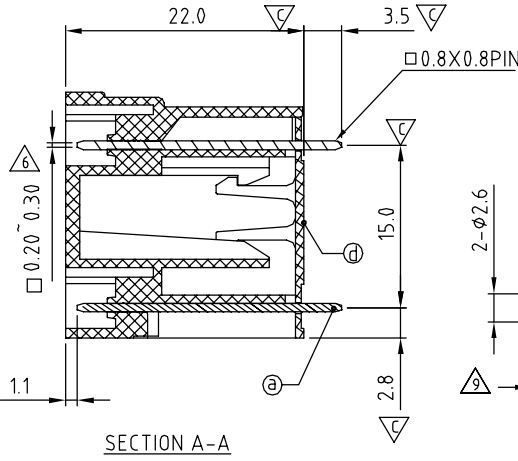
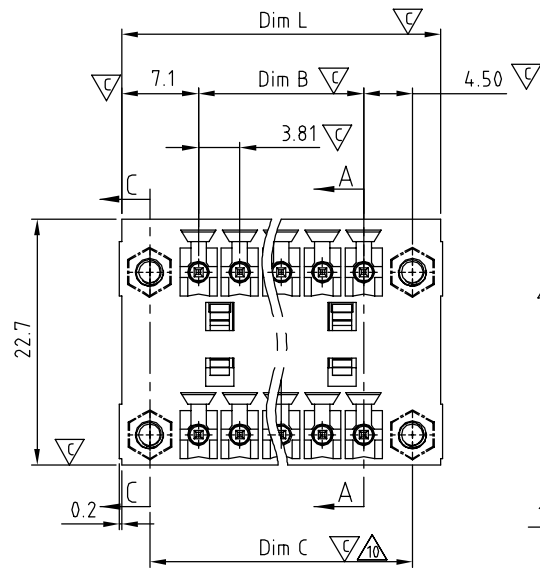

- Material:
- Item ③ Contact pin: Copper Tin plated
 - Item ④ Terminal(housing): Thermoplastic (UL94V-0)
 - Item ⑤ With flange nut: Brass ,M2.5
 - Item ⑥ Terminal(cover): Thermoplastic (UL94V-0)
- Electrical:
- Voltage rating: 300V
 - Current rating: 10A
 - Withstanding Voltage: 1.6 KV
- ④ ● Operating temperature: -40°C to +115°C
- ① ● Soldering temperature: 250°C±10°C/5 Sec
- Safety Approval:
- Critical dimension:

VL xx 3 2 x 0 xxxx G

- No. OF POLES
- 04: 2x2 POLES
 - :
 - 48: 2x24 POLES
- COLOR
- 0 Black (RAL9005)
 - 2 Red (RAL3001/D)
 - 3 Orange(RAL2011/P)
 - 4 Yellow(RAL1018/A)
 - 5 Green(RAL6018/T)
 - 6 Blue (RAL5015/A)
 - 8 Grey(RAL7035/D)
- G: RoHS compliant (lead<4%) In copper Alloy
- 0000: "@" Logo
- 000A: "ANYTEK" Mark
- Any special item by customer request. please contact sales department.

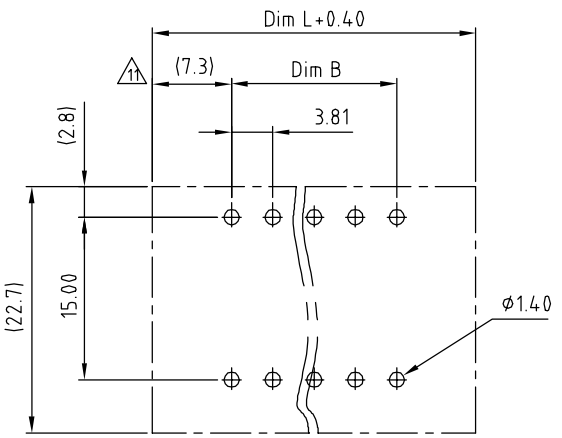

N = Number of poles △

Dim L=(N-1)×3.81+14.2

Dim B=(N-1)×3.81

Dim C=(N-1)×3.81+9.0

Poles	Dim L	Dim B	Dim C
2×2-2×6p	±0.15	±0.15	±0.15
2×7-2×12p	±0.25	±0.25	±0.25
2×13-2×18p	±0.35	±0.35	±0.35
2×19-2×24p	±0.40	±0.40	±0.40

ANYTEK				CUSTOMER COPY			
ALL RIGHTS RESERVED. REPRODUCTION OR ISSUE TO THIRD PARTIES IN ANY FORM WHATSOEVER IS NOT PERMITTED WITHOUT WRITTEN AUTHORITY FROM THE PROPRIETOR. PROPERTY OF ANYTEK TECHNOLOGY CO., LTD							
TITLE	VL-3.81mm Vertical Series with flange						
PART NO.	VLxx32x0xxxxG			DWG NO.	8VL0103		
APPROVED	CHECKED	DESIGNED	DRAWN	CUST NO.	Tolerance		
		Chen Bo 04/23'12	Chen Bo 04/23'12		UNIT: mm	X.	±0.50
					SCALE: NONE	X.X	±0.30
					REV.: F	X.XX	±0.10
						X°	±1°
				SHEET: 01/01			