

### DESCRIPTION

- Max. shift frequency of 700MHz
- Clock to Q delay max. of 1100ps
- IEE min. of -170mA
- Internal 75KΩ input pull-down resistors
- Industry standard 100K ECL levels
- Extended supply voltage option:  
VEE = -4.2V to -5.5V
- Voltage and temperature compensation for improved noise immunity
- 50% faster than Fairchild 300K at lower power
- Function and pinout compatible with Fairchild F100K
- Available in 24-pin CERPACK and 28-pin PLCC packages

The SY100S336 functions either as a modulo-16 up/down counter or as a 4-bit bidirectional shift register and is designed for use in high-performance ECL systems. Three Select inputs (Sn) are provided for determining the mode of operation. The Function Table lists the available modes of operation. In order to allow cascading for multistage counters, two Count Enable controls (CEP, CET) are provided. The CET input also functions as the Serial Data input (So) for a shift-up operation, while the D3 input serves as the Serial Data input for the shift-down operation.

When the device is in the counting mode, the Terminal Count (TC) goes to a logical LOW when the count reaches 15 for count-up or reaches 0 for count-down. When in the shift mode, the TC output simply repeats the Q3 output.

The flexibility provided by the TC/Q3 output and the D0/CET input allows these signals to be interconnected from one stage to the next higher stage for multistage counting or shift-up operations. The individual Presets (Pn) allow initialization of the counter by entering data in parallel to preset the counter. A logic HIGH on the Master Reset (MR) overrides all other inputs and asynchronously clears the flip-flops. An additional synchronous Clear is provided, as well as a complement function which synchronously inverts the contents of the flip-flops. All inputs have 75KΩ pull-down resistors.

### PIN NAMES

Pin	Function
CP	Clock Pulse Input
CEP	Count Enable Parallel Input (Active LOW)
D0/CET	Serial Data Input/Count Enable Trickle Input (Active LOW)
S0 — S2	Select Inputs
MR	Master Reset Input
VEES	VEE Substrate
VCCA	VCCO for ECL Outputs
P0 — P3	Preset Inputs
D3	Serial Data Input
TC	Terminal Count Output
Q0 — Q3	Data Outputs
Q0 — Q3	Complementary Data Outputs

**PACKAGE/ORDERING INFORMATION**

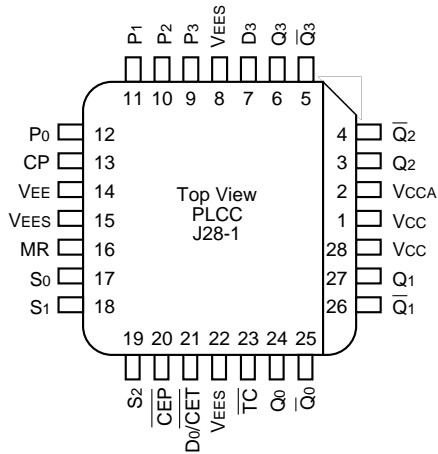

**28-Pin PLCC (J28-1)**

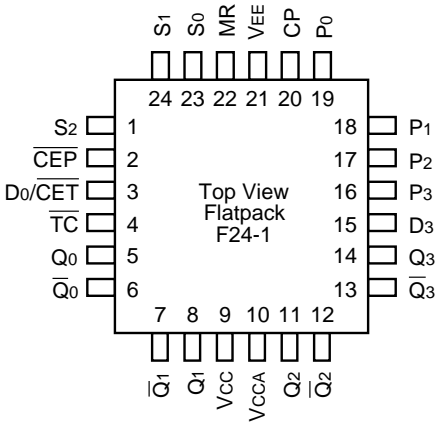

**24-Pin Cerpack (F24-1)**

**Ordering Information**

Part Number	Package Type	Operating Range	Package Marking	Lead Finish
SY100S336FC	F24-1	Commercial	SY100S336FC	Sn-Pb
SY100S336FCTR <sup>(1)</sup>	F24-1	Commercial	SY100S336FC	Sn-Pb
SY100S336JC	J28-1	Commercial	SY100S336JC	Sn-Pb
SY100S336JCTR <sup>(1)</sup>	J28-1	Commercial	SY100S336JC	Sn-Pb
SY100S336JZ <sup>(2)</sup>	J28-1	Commercial	SY100S336JZ with Pb-Free bar-line indicator	Matte-Sn
SY100S336JZTR <sup>(1, 2)</sup>	J28-1	Commercial	SY100S336JZ with Pb-Free bar-line indicator	Matte-Sn

**Notes:**

1. Tape and Reel.
2. Pb-Free package is recommended for new designs.

**BLOCK DIAGRAM**

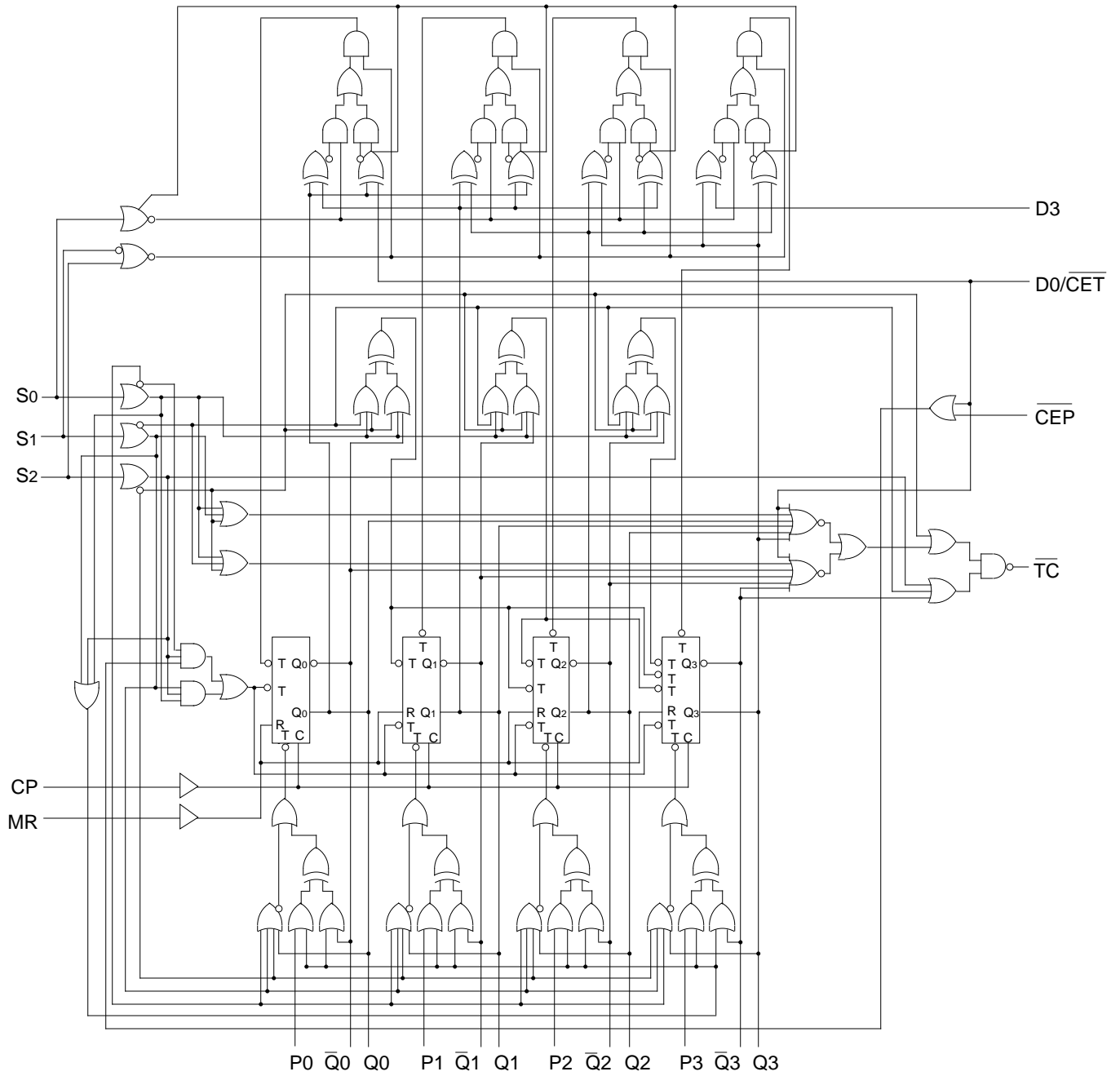

**TRUTH TABLE<sup>(1)</sup>**

Inputs								Outputs					
MR	S <sub>2</sub>	S <sub>1</sub>	S <sub>0</sub>	$\overline{CEP}$	D <sub>0</sub> / $\overline{CET}$	D <sub>3</sub>	CP	Q <sub>0</sub>	Q <sub>1</sub>	Q <sub>2</sub>	Q <sub>3</sub>	$\overline{TC}$	Mode
L	L	L	L	X	X	X	u	P <sub>0</sub>	P <sub>1</sub>	P <sub>2</sub>	P <sub>3</sub>	L	Preset (Parallel Load)
L	L	L	H	X	X	X	u	$\overline{Q_0}$	$\overline{Q_1}$	$\overline{Q_2}$	$\overline{Q_3}$	L	Invert
L	L	H	L	X	X	X	u	Q <sub>1</sub>	Q <sub>2</sub>	Q <sub>3</sub>	D <sub>3</sub>	D <sub>3</sub>	Shift Left
L	L	H	H	X	X	X	u	D <sub>0</sub>	Q <sub>0</sub>	Q <sub>1</sub>	Q <sub>2</sub>	Q <sub>3</sub> *	Shift Right
L	H	L	L	L	L	X	u	(Q <sub>0-3</sub> ) minus 1				①	Count Down
L	H	L	L	H	L	X	X	Q <sub>0</sub>	Q <sub>1</sub>	Q <sub>2</sub>	Q <sub>3</sub>	①	Count Down with $\overline{CEP}$ Not Active
L	H	L	L	X	H	X	X	Q <sub>0</sub>	Q <sub>1</sub>	Q <sub>2</sub>	Q <sub>3</sub>	H	Count Down with $\overline{CET}$ Not Active
L	H	L	H	X	X	X	u	L	L	L	L	H	Clear
L	H	H	L	L	L	X	u	(Q <sub>0-3</sub> ) plus 1				≠	Count Up
L	H	H	L	H	L	X	X	Q <sub>0</sub>	Q <sub>1</sub>	Q <sub>2</sub>	Q <sub>3</sub>	≠	Count Up with $\overline{CEP}$ Not Active
L	H	H	L	X	H	X	X	Q <sub>0</sub>	Q <sub>1</sub>	Q <sub>2</sub>	Q <sub>3</sub>	H	Count Up with $\overline{CET}$ Not Active
L	H	H	H	X	X	X	X	Q <sub>0</sub>	Q <sub>1</sub>	Q <sub>2</sub>	Q <sub>3</sub>	H	Hold
H	L	L	L	X	X	X	X	L	L	L	L	L	Asynchronous Master Reset
H	L	L	H	X	X	X	X	L	L	L	L	L	
H	L	H	L	X	X	X	X	L	L	L	L	L	
H	L	H	H	X	X	X	X	L	L	L	L	L	
H	H	L	L	X	L	X	X	L	L	L	L	L	
H	H	L	H	X	H	X	X	L	L	L	L	H	
H	H	L	L	X	X	X	X	L	L	L	L	H	
H	H	H	L	X	X	X	X	L	L	L	L	H	

**NOTE:**

- 1. H = High Voltage Level
- L = Low Voltage Level
- X = Don't Care
- u = LOW-to-HIGH Transition
- ① = L if Q<sub>0</sub> – Q<sub>3</sub> = LLLL  
H if Q<sub>0</sub> – Q<sub>3</sub> ≠ LLLL
- ≠ = L if Q<sub>0</sub> – Q<sub>3</sub> = HHHH  
H if Q<sub>0</sub> – Q<sub>3</sub> ≠ HHHH
- \* Before the clock,  $\overline{TC}$  is Q<sub>3</sub>; after the clock,  $\overline{TC}$  is Q<sub>2</sub>

V<sub>EE</sub> = -4.2V to -5.5V unless otherwise specified, V<sub>CC</sub> = V<sub>CCA</sub> = GND

Symbol	Parameter	Min.	Typ.	Max.	Unit	Condition
I <sub>IH</sub>	Input HIGH Current, All Inputs	—	—	200	μA	V <sub>IN</sub> = V <sub>IH</sub> (Max.)
I <sub>EE</sub>	Power Supply Current	-170	-145	-90	mA	Inputs Open

## AC ELECTRICAL CHARACTERISTICS

### CERPACK

VEE = -4.2V to -5.5V unless otherwise specified, VCC = VCCA = GND

Symbol	Parameter	TA = 0°C		TA = +25°C		TA = +85°C		Unit	Condition
		Min.	Max.	Min.	Max.	Min.	Max.		
fshift	Shift Frequency	—	700	—	700	—	—	MHz	
tPLH tPHL	Propagation Delay CP to Qn, $\bar{Q}_n$	450	1200	450	1200	450	1200	ps	
tPLH tPHL	Propagation Delay CP to $\bar{TC}$	600	1900	600	1900	600	1900	ps	
tPLH tPHL	Propagation Delay MR to Qn, $\bar{Q}_n$	500	1400	500	1400	500	1400	ps	
tPLH tPHL	Propagation Delay MR to $\bar{TC}$	600	1900	600	1900	600	1900	ps	
tPLH tPHL	Propagation Delay D0/ $\bar{CET}$ to $\bar{TC}$	400	1200	400	1200	400	1200	ps	
tPLH tPHL	Propagation Delay Sn to $\bar{TC}$	1500	2600	1500	2600	1500	2600	ps	
tTLH tTHL	Transition Time 20% to 80%, 80% to 20%	900	300	900	300	900	300	ps	
ts	Set-up Time							ps	
	D3	800	—	800	—	800	—		
	Pn	800	—	800	—	800	—		
	D0/ $\bar{CET}$ to $\bar{CEP}$	700	—	700	—	700	—		
	Sn	2000	—	2000	—	2000	—		
	MR (Release Time)	900	—	900	—	900	—		
th	Hold Time							ps	
	D3	200	—	200	—	200	—		
	Pn	200	—	200	—	200	—		
	D0/ $\bar{CET}$ to $\bar{CEP}$	200	—	200	—	200	—		
	Sn	-600	—	-600	—	-600	—		
tpw (H)	Pulse Width HIGH, CP, MR	—	800	—	800	—	800	ps	

## AC ELECTRICAL CHARACTERISTICS

### PLCC

VEE = -4.2V to -5.5V unless otherwise specified, VCC = VCCA = GND

Symbol	Parameter	TA = 0°C		TA = +25°C		TA = +85°C		Unit	Condition
		Min.	Max.	Min.	Max.	Min.	Max.		
fshift	Shift Frequency	—	700	—	700	—	700	MHz	
tPLH tPHL	Propagation Delay CP to Qn, Qn	450	1100	450	1100	450	1100	ps	
tPLH tPHL	Propagation Delay CP to $\overline{TC}$	600	1800	600	1800	600	1800	ps	
tPLH tPHL	Propagation Delay MR to Qn, $\overline{Qn}$	500	1300	500	1300	500	1300	ps	
tPLH tPHL	Propagation Delay MR to $\overline{TC}$	600	1800	600	1800	600	1800	ps	
tPLH tPHL	Propagation Delay D0/ $\overline{CET}$ to $\overline{TC}$	400	1100	400	1100	400	1100	ps	
tPLH tPHL	Propagation Delay Sn to $\overline{TC}$	1500	2500	1500	2500	1500	2500	ps	
tTLH tTHL	Transition Time 20% to 80%, 80% to 20%	300	900	300	900	300	900	ps	
ts	Set-up Time							ps	
	D3	800	—	800	—	800	—		
	Pn	800	—	800	—	800	—		
	D0/ $\overline{CET}$ to $\overline{CEP}$	700	—	700	—	700	—		
	Sn	2000	—	2000	—	2000	—		
	MR (Release Time)	900	—	900	—	900	—		
th	Hold Time							ps	
	D3	200	—	200	—	200	—		
	Pn	200	—	200	—	200	—		
	D0/ $\overline{CET}$ to $\overline{CEP}$	200	—	200	—	200	—		
	Sn	-600	—	-600	—	-600	—		
tpw (H)	Pulse Width HIGH, CP, MR	—	800	—	800	—	800	ps	

**TIMING DIAGRAMS**

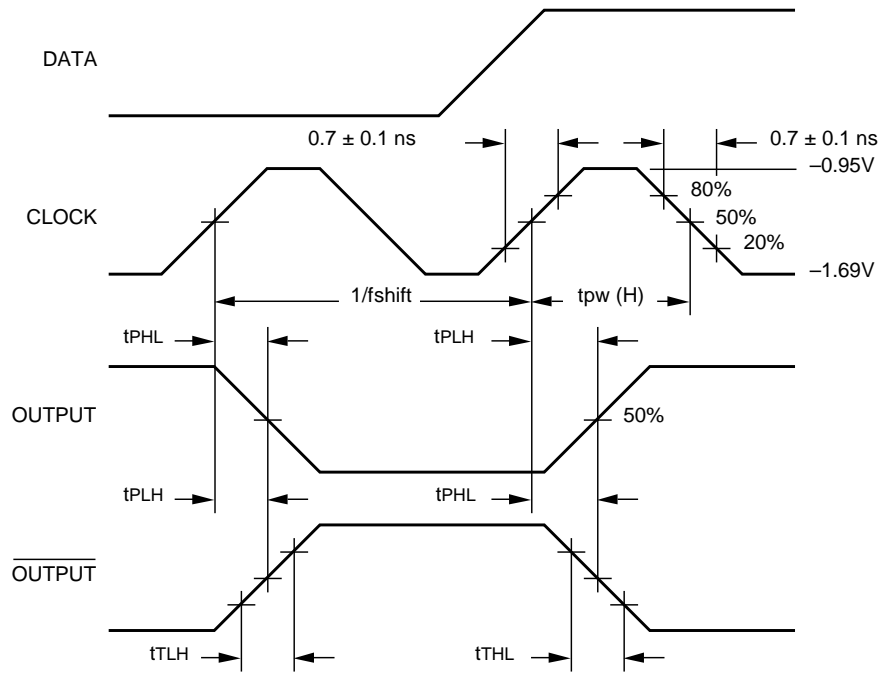

**Propagation Delay (Clock) and Transition Times**

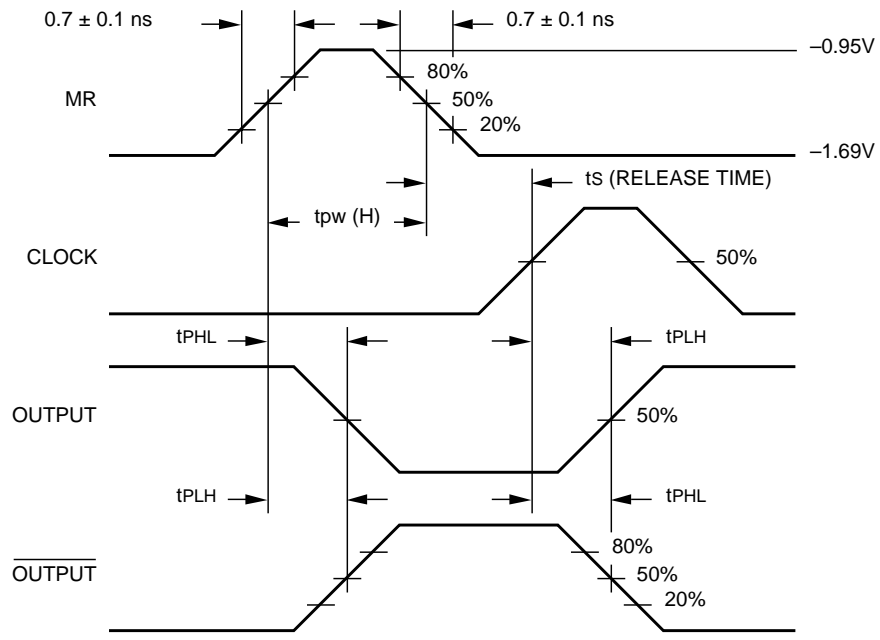

**Propagation Delay (Reset)**

**TIMING DIAGRAMS**

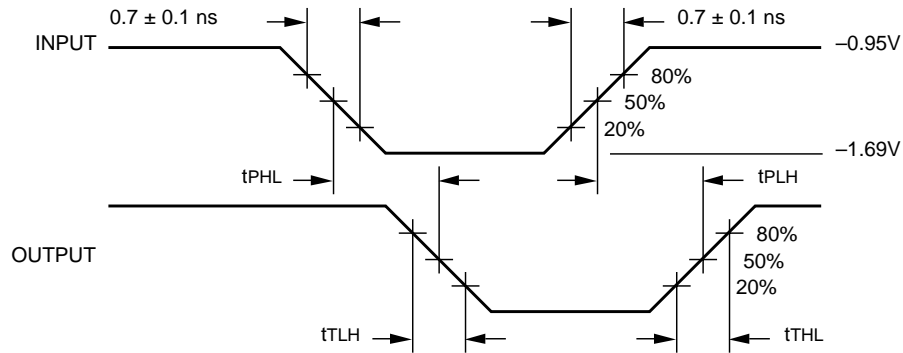

**Propagation Delay (Serial Data, Selects)**

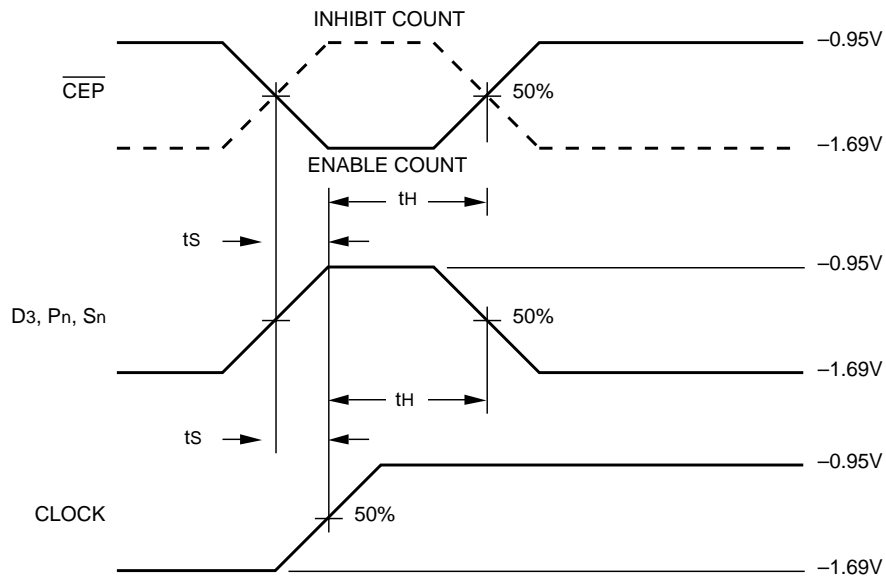

**Set-up and Hold Time**

**Notes:**

1.  $V_{EE} = -4.2V$  to  $-5.5V$  unless otherwise specified,  $V_{CC} = V_{CCA} = GND$ .
2.  $t_s$  is the minimum time before the transition of the clock that information must be present at the data input.
3.  $t_h$  is the minimum time after the transition of the clock that information must remain unchanged at the data input.



**24-PIN CERPACK (F24-1)**

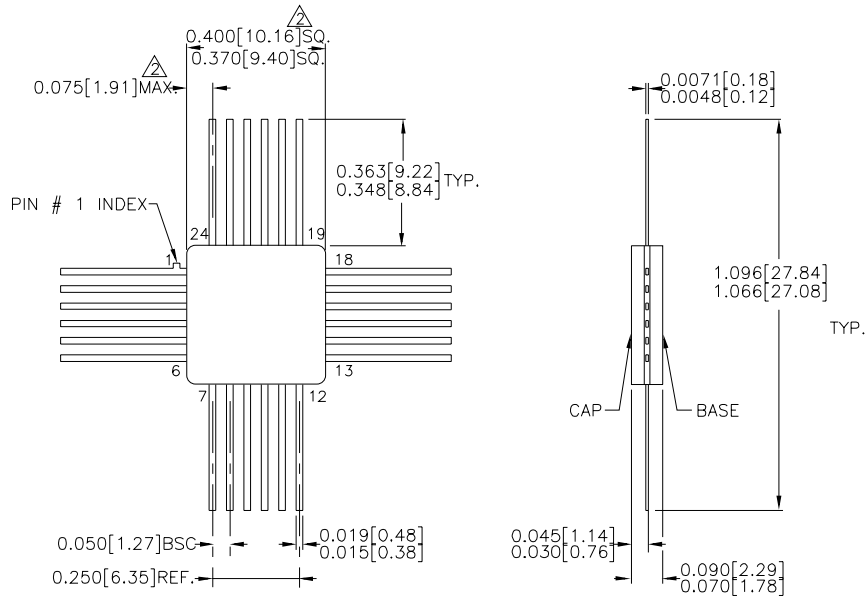

- NOTES:**
1. DIMENSIONS ARE IN INCHES[MM].
  2. THIS DIMENSION INCLUDES GLASS PROTRUSION AND CAP TO BASE ALIGNMENT TOLERANCES.
  3. DIMENSIONS SHOWN ARE MAX/MIN, WHERE NOTED.

Rev. 03

**28-PIN PLCC (J28-1)**

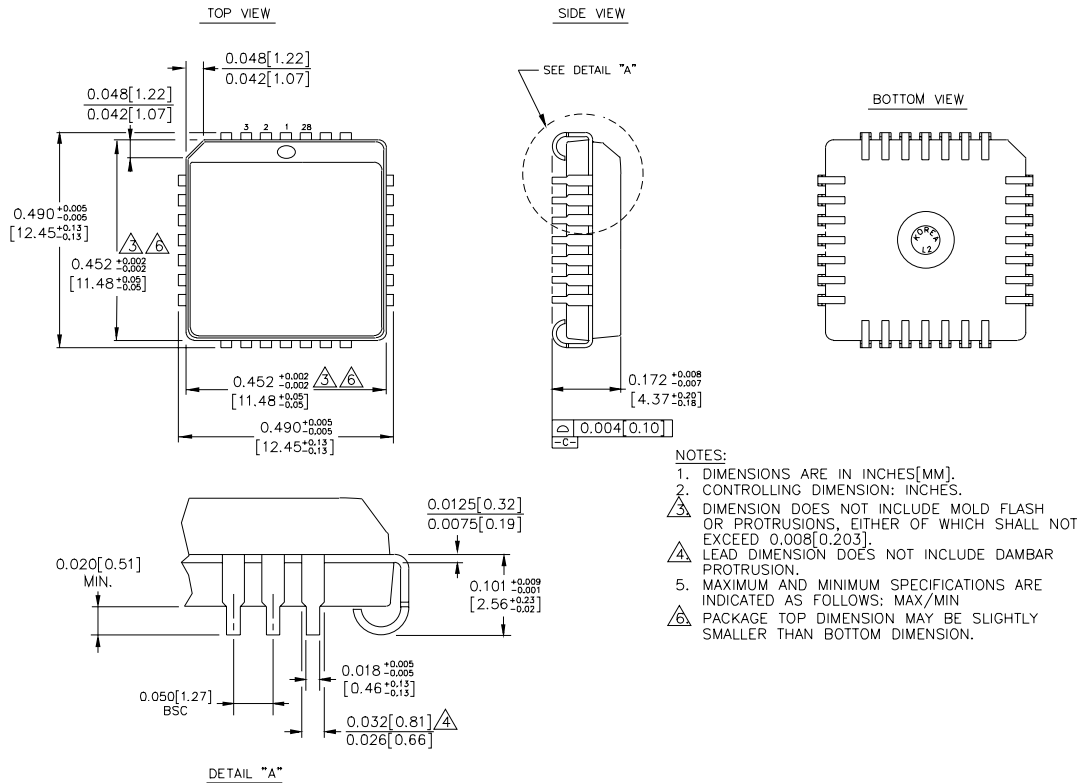

Rev. 03

**MICREL, INC. 2180 FORTUNE DRIVE SAN JOSE, CA 95131 USA**

TEL + 1 (408) 944-0800 FAX + 1 (408) 474-1000 WEB <http://www.micrel.com>

The information furnished by Micrel in this data sheet is believed to be accurate and reliable. However, no responsibility is assumed by Micrel for its use. Micrel reserves the right to change circuitry and specifications at any time without notification to the customer.

Micrel Products are not designed or authorized for use as components in life support appliances, devices or systems where malfunction of a product can reasonably be expected to result in personal injury. Life support devices or systems are devices or systems that (a) are intended for surgical implant into the body or (b) support or sustain life, and whose failure to perform can be reasonably expected to result in a significant injury to the user. A Purchaser's use or sale of Micrel Products for use in life support appliances, devices or systems is at Purchaser's own risk and Purchaser agrees to fully indemnify

Micrel for any damages resulting from such use or sale.

© 2006 Micrel, Incorporated.