NI-9269

Specifications

2022-10-07

Contents

NI 9269 Datasheet.....	3
NI 9269 Specifications.....	7

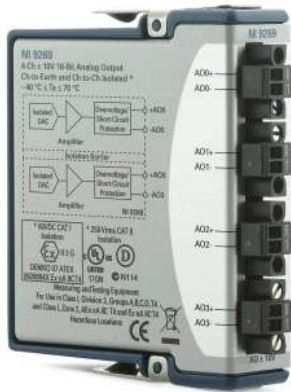

NI 9269 Datasheet



- Screw Terminal connectivity
- 250 V RMS, CAT II, channel-to-channel isolation

The NI 9269 is a four-channel, 100 kS/s per channel, channel-to-channel isolated module for any NI CompactRIO and NI CompactDAQ chassis. Similar to the NI 9263 module, the NI 9269 adds channel-to-channel isolation for increased safety, improved signal quality, and the ability to stack channels to output up to 40 V. NI CompactDAQ support has been added as of NI-DAQmx Version 9.1. Channel-to-channel isolation is commonly needed for applications that have multiple electrical systems, such as automotive test, or industrial applications that are subjected to increased noise and often contain multiple ground planes.

C SERIES ANALOG OUTPUT MODULE COMPARISON							
Product Name	Module Type	Signal Ranges	Channels	Update Rate	Isolation	Resolution	Connectivity
NI 9260	Voltage Output	3 V RMS	2	51.2 kS/s/ch	None	24-Bit	BNC, mini XLR
NI 9262	Voltage Output	± 10 V	6	1 MS/s/ch	60 V DC Ch-Earth	16-Bit	37-Pin DSUB
NI 9263	Voltage Output	± 10 V	4	100 kS/s/ch	250 V RMS Ch-Earth	16-Bit	Screw Terminal, Spring Terminal
NI 9264	Voltage Output	± 10 V	16	25 kS/s/ch	250 V RMS Ch-Earth (Spring) 60 V DC Ch-Earth (DSUB)	16-Bit	Spring Terminal, 37-Pin DSUB
NI 9265	Current Output	0 mA to 20 mA	4	100 kS/s/ch	250 V RMS Ch-Earth, Vsup-Earth, COM-Earth	16-Bit	Screw Terminal
NI 9266	Current Output	0 mA to 20 mA	8	24 kS/s/ch	250 V RMS Ch-Earth (Screw) 60 V DC Ch-Earth (DSUB)	16-Bit	Screw Terminal, 37-Pin DSUB
NI 9269	Voltage Output	± 10 V	4	100 kS/s/ch	250 V RMS Ch-Ch 250 V RMS Ch-Earth	16-Bit	Screw Terminal

	Kit Contents	<ul style="list-style-type: none"> • NI 9269 • NI 9269 Getting Started Guide
	Accessories	<ul style="list-style-type: none"> • NI 9971 backshell kit

NI C Series Overview



NI provides more than 100 C Series modules for measurement, control, and communication applications. C Series modules can connect to any sensor or bus and allow for high-accuracy measurements that meet the demands of advanced data acquisition and control applications.

- Measurement-specific signal conditioning that connects to an array of sensors and signals
- Isolation options such as bank-to-bank, channel-to-channel, and channel-to-earth ground
- -40 °C to 70 °C temperature range to meet a variety of application and environmental needs
- Hot-swappable

The majority of C Series modules are supported in both CompactRIO and CompactDAQ platforms and you can move modules from one platform to the other with no modification.

CompactRIO



CompactRIO combines an open-embedded architecture with small size, extreme ruggedness, and C Series modules in a platform powered by the NI LabVIEW reconfigurable I/O (RIO) architecture. Each system contains an FPGA for custom timing, triggering, and processing with a wide array of available modular I/O to meet any embedded application requirement.

CompactDAQ

CompactDAQ is a portable, rugged data acquisition platform that integrates connectivity, data acquisition, and signal conditioning into modular I/O for directly interfacing to any sensor or signal. Using CompactDAQ with LabVIEW, you can easily customize how you acquire, analyze, visualize, and manage your measurement data.



Software

LabVIEW Professional Development System for Windows



- Use advanced software tools for large project development
- Generate code automatically using DAQ Assistant and Instrument I/O Assistant
- Use advanced measurement analysis and digital signal processing
- Take advantage of open connectivity with DLLs, ActiveX, and .NET objects
- Build DLLs, executables, and MSI installers

NI LabVIEW FPGA Module

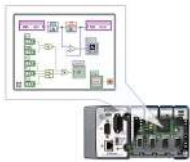

- Design FPGA applications for NI RIO hardware
- Program with the same graphical environment used for desktop and real-time applications
- Execute control algorithms with loop rates up to 300 MHz
- Implement custom timing and triggering logic, digital protocols, and DSP algorithms
- Incorporate existing HDL code and third-party IP including Xilinx IP generator functions
- Purchase as part of the LabVIEW Embedded Control and Monitoring Suite

NI LabVIEW Real-Time Module

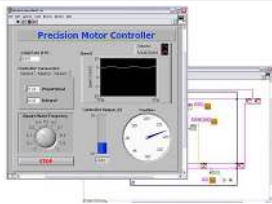

- Design deterministic real-time applications with LabVIEW graphical programming
- Download to dedicated NI or third-party hardware for reliable execution and a wide selection of I/O
- Take advantage of built-in PID control, signal processing, and analysis functions
- Automatically take advantage of multicore CPUs or set processor affinity manually
- Take advantage of real-time OS, development and debugging support, and board support
- Purchase individually or as part of a LabVIEW suite

Circuitry

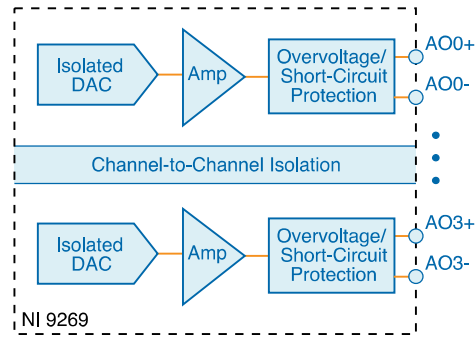

The analog output channels are floating with respect to earth ground and each other. Each channel has a digital-to-analog converter (DAC) that produces a voltage signal. Each channel provides an independent signal path, enabling you to update all four channels simultaneously. Each channel also has overvoltage and short-circuit protection.

NI 9269 Specifications

The following specifications are typical for the range $-40\text{ }^{\circ}\text{C}$ to $70\text{ }^{\circ}\text{C}$ unless otherwise noted. All voltages are relative to the AO- signal on each channel unless otherwise noted.

Caution Do not operate the NI-9269 in a manner not specified in this document. Product misuse can result in a hazard. You can compromise the safety protection built into the product if the product is damaged in any way. If the product is damaged, return it to NI for repair.

Output Characteristics

Number of channels	4 analog output channels
DAC resolution	16 bits
Type of DAC	R-2R
Power-on output state	High impedance
Startup voltage ^[1]	0 V

Power-down output state ^[2]	High impedance		
Output voltage range^[3]			
Nominal	±10 V		
Minimum	±10.38 V		
Typical	±10.47 V		
Maximum	±10.56 V		
Current drive	±20 mA all channels maximum; ±10 mA per channel typical		
Output impedance	100 mΩ		
Measurement Conditions		Percent of Reading (Gain Error)	Percent of Range ^[4] (Offset Error)
Calibrated	Maximum (-40 °C to 70 °C)	0.17%	0.15%
	Typical (25 °C, ±5 °C)	0.05%	0.01%
Uncalibrated ^[5]	Maximum (-40 °C to 70 °C)	0.44%	0.37%
	Typical (25 °C, ±5 °C)	0.14%	0.05%

Table 1. Accuracy

Stability		
Gain drift	5 ppm/°C	
Offset drift	80 μV/°C	
Protection		
Overvoltage	±30 V	
Short-circuit	Indefinitely	
Number of Channels	Update Time for NI cRIO-9151 R Series Expansion Chassis	Update Time for All Other Chassis
1	3.5 μs minimum	3 μs minimum
2	6.5 μs minimum	5 μs minimum
3	9.3 μs minimum	7.5 μs minimum

Number of Channels	Update Time for NI cRIO-9151 R Series Expansion Chassis	Update Time for All Other Chassis
4	12.3 μ s minimum	9.7 μ s minimum

Table 2. Update Time

Noise	300 μ Vrms
Slew rate	7 V/ μ s
Crosstalk	
Channel-to-channel	100 dB
Common-mode voltage	120 dB
Settling time	
100 pF load, to 1 LSB	
Full-scale step	20 μ s
1 V step	10 μ s
0.1 V step	10 μ s
1 kΩ 100 pF load, to 4 LSB	
Full-scale step	20 μ s
Capacity drive	1,500 pF maximum
Monotonicity	16 bits
DNL	\pm 1 LSB maximum
INL (best fit)	\pm 2 LSBs maximum

Power Requirements

Power consumption from chassis	
Active mode	1 W maximum

Sleep mode	120 μ W maximum
Thermal dissipation (at 70 °C)	
Active mode	1.4 W maximum
Sleep mode	77 mW maximum

Physical Characteristics

Screw-terminal wiring

Gauge	0.05 mm ² to 1.5 mm ² (30 AWG to 14 AWG) copper conductor wire	
Wire strip length	6 mm (0.24 in.) of insulation stripped from the end	
Temperature rating	90 °C, minimum	
Torque for screw terminals	0.22 N · m to 0.25 N · m (1.95 lb · in. to 2.21 lb · in.)	
Wires per screw terminal	One wire per screw terminal; two wires per screw terminal using a 2-wire ferrule	
Ferrules	0.25 mm ² to 1.5 mm ²	
Connector securement		
Securement type	Screw flanges provided	
Torque for screw flanges	0.2 N · m (1.80 lb · in.)	

Safety Voltages

Channel-to-channel	
Continuous	250 V RMS, Measurement Category II
Withstand	1,390 V RMS, verified by a 5 s dielectric withstand test
Channel-to-earth ground	

Continuous	250 V RMS, Measurement Category II
Withstand	2,300 V RMS, verified by a 5 s dielectric withstand test
Division 2/Zone 2 hazardous locations applications (Channel-to-channel and channel-to-earth ground)	60 V DC, Measurement Category I

Note Measurement Categories CAT I and CAT O are equivalent. These test and measurement circuits are for other circuits not intended for direct connection to the MAINS building installations of Measurement Categories CAT II, CAT III, or CAT IV.

Hazardous Locations

U.S. (UL)	Class I, Division 2, Groups A, B, C, D, T4; Class I, Zone 2, AEx nA IIC T4 Gc
Canada (C-UL)	Class I, Division 2, Groups A, B, C, D, T4; Ex nA IIC T4 Gc
Europe (ATEX) and International (IECEX)	Ex nA IIC T4 Gc DEMKO 07 ATEX 0626664X IECEX UL 14.0089X

Safety Compliance and Hazardous Locations Standards

This product is designed to meet the requirements of the following electrical equipment safety standards for measurement, control, and laboratory use:

- IEC 61010-1, EN 61010-1
- UL 61010-1, CSA C22.2 No. 61010-1
- EN 60079-0, EN 60079-7
- IEC 60079-0, IEC 60079-7
- UL 60079-0, UL 60079-7
- CSA C22.2 No. 60079-0, CSA C22.2 No. 60079-7

Note For safety certifications, refer to the product label or the [Product Certifications and Declarations](#) section.

Electromagnetic Compatibility

- EN 61326 (IEC 61326): Class A emissions; Industrial immunity

Note For the standards applied to assess the EMC of this product, refer to the [Online Product Certification](#) section.

CE Compliance

- 2014/34/EU; Potentially Explosive Atmospheres (ATEX)

Product Certifications and Declarations

Refer to the product Declaration of Conformity (DoC) for additional regulatory compliance information. To obtain product certifications and the DoC for NI products, visit ni.com/product-certifications, search by model number, and click the appropriate link.

Shock and Vibration

To meet these specifications, you must panel mount the system.

Operating vibration	
Random	5 g RMS, 10 Hz to 500 Hz
Sinusoidal	5 g, 10 Hz to 500 Hz
Operating shock	30 g, 11 ms half sine; 50 g, 3 ms half sine; 18 shocks at 6 orientations

Environmental

Refer to the manual for the chassis you are using for more information about meeting these specifications.

Operating temperature (IEC 60068-2-1, IEC 60068-2-2)	-40 °C to 70 °C
Storage temperature (IEC 60068-2-1, IEC 60068-2-2)	-40 °C to 85 °C
Ingress protection	IP40
Operating humidity (IEC 60068-2-30)	10% RH to 90% RH, noncondensing
Storage humidity (IEC 60068-2-30)	5% RH to 95% RH, noncondensing
Pollution Degree	2
Maximum altitude	2,000 m

Indoor use only.

Environmental Management

NI is committed to designing and manufacturing products in an environmentally responsible manner. NI recognizes that eliminating certain hazardous substances from our products is beneficial to the environment and to NI customers.

For additional environmental information, refer to the **Engineering a Healthy Planet** web page at ni.com/environment. This page contains the environmental regulations and directives with which NI complies, as well as other environmental information not included in this document.

EU and UK Customers

-  **Waste Electrical and Electronic Equipment (WEEE)**—At the end of the product life cycle, all NI products must be disposed of according to local laws and regulations. For more information about how to recycle NI products in your region, visit ni.com/environment/weee.

电子信息产品污染控制管理办法（中国 RoHS）

-  中国 RoHS— NI 符合中国电子信息产品中限制使用某些有害物质指令(RoHS)。关于 NI 中国 RoHS 合规性信息，请登录 ni.com/environment/rohs_china。(For information about China RoHS compliance, go to ni.com/environment/rohs_china.)

Calibration

You can obtain the calibration certificate and information about calibration services for the NI 9269 at ni.com/calibration.

Calibration interval	1
----------------------	---

¹ When the output stage powers on, a glitch occurs for 5 μ s peaking at -900 mV.

² When the module powers down, a glitch occurs for 20 μ s peaking at -600 mV.

³ Refer to the device Getting Started Guide on ni.com/manuals for information about the stacked nominal output voltage range and current drive.

⁴ Range equals 10.47 V

⁵ Uncalibrated accuracy refers to the accuracy achieved when acquiring in raw or unscaled modes where the calibration constants stored in the module are not applied to the data.