

QMA

Adaptor
QMA Jack – SMA Plug

28K132-S00N5

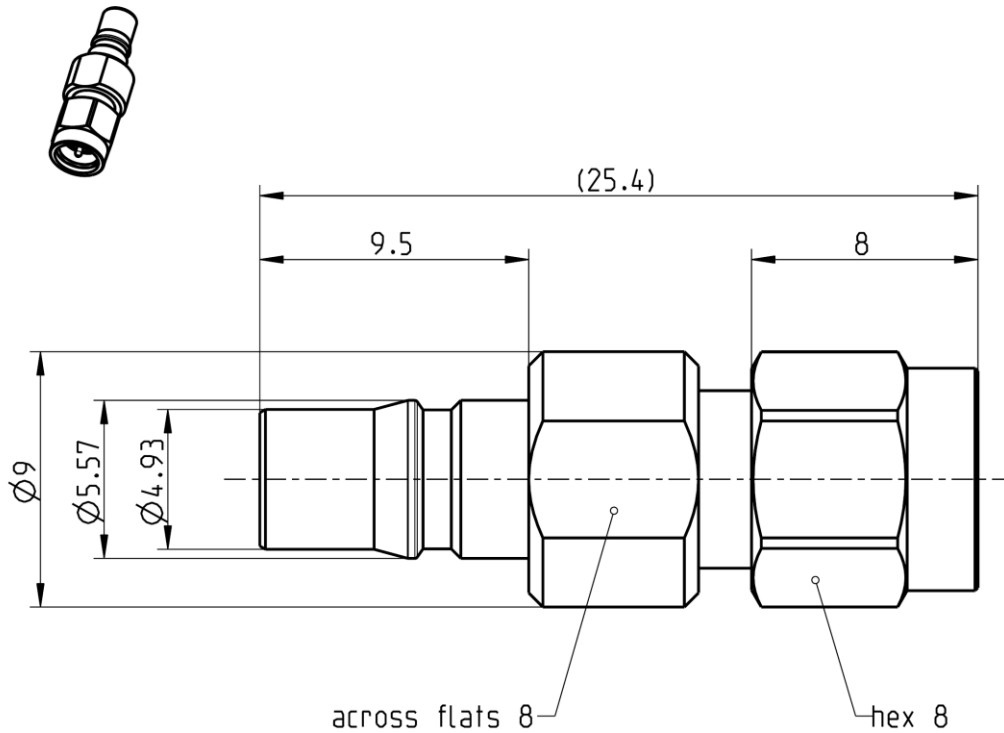

All dimensions are in mm; tolerances according to ISO 2768 m-H

Interface

According to QMA side: IEC 61169-50
SMA side: IEC 60169-15; EN 122110; MIL-STD-348A, Fig. 310

Documents

N/A

Material and plating

Connector parts

Center contact
Outer contact
Dielectric

Material

CuBe
Brass
PTFE

Plating

AuroDur®, gold plated
White bronze(e.g. Optalloy®)

Dieses Dokument ist urheberrechtlich geschützt • This document is protected by copyright • Rosenberger Hochfrequenztechnik GmbH & Co. KG

RF_35/09.14/6.2

Electrical data

Impedance	50 Ω	
Frequency	DC to 18 GHz	
Return loss	≥ 32 dB, DC to 3 GHz	
	≥ 28 dB, 3 to 6 GHz	
Insertion loss	≤ 0.03 x √f(GHz) dB, DC to 6 GHz	
Insulation resistance	≥ 5 x10 ³ MΩ	
Center contact resistance	≤ 3 mΩ, QMA side	≤ 3 mΩ, SMA side
Outer contact resistance	≤ 2.5 mΩ, QMA side	≤ 2 mΩ, SMA side
Test voltage	1000 V rms	
Working voltage	480 V rms	
RF-leakage	≥ 95 dB up to 2 GHz	
	≥ 80 dB up to 4 GHz	
	≥ 70 dB up to 6 GHz	

Mechanical data

	QMA side	SMA side
Mating cycles	min. 100	min. 100
Coupling nut retention	N/A	≥ 180 N
Center contact captivation: axial	≥ 20 N	≥ 20 N
Coupling test torque	N/A	0.5 Nm
Recommended torque	N/A	max. 0.6 Nm
Engagement force	typ. 25 N	N/A
Disengagement force	typ. 20 N	N/A
Retention force for interface	60 N min.	N/A

Environmental data

Temperature range	-40°C to +85°C
Storage temperature	-40°C to +85°C
Thermal shock	IEC 60169-1 16.4 (-40 / +85°C)
Corrosion	IEC 60169-1 16.7 (48 hrs)
Vibration	IEC 60068-2-64 random
Damp heat, steady state	IEC 60169-1 16.3 (96 hrs)
RoHS	compliant

Tooling

N/A

Suitable cables

N/A

Weight

Weight 5.8 g/pce

While the information has been carefully compiled to the best of our knowledge, nothing is intended as representation or warranty on our part and no statement herein shall be construed as recommendation to infringe existing patents. In the effort to improve our products, we reserve the right to make changes judged to be necessary.

For the installation of the electrotechnical equipment, particular electrotechnical expertise is required.



Dieses Dokument ist urheberrechtlich geschützt • This document is protected by copyright • Rosenberger Hochfrequenztechnik GmbH & Co. KG

RF_35/09.14/6.2

Draft	Date	Approved	Date	Rev.	Engineering change number	Name	Date
König A.	02.02.06	Chr. Janßen	02.11.20	e00	20-1927	S. Huber-Siegl	02.11.20
Rosenberger Hochfrequenztechnik GmbH & Co. KG P.O.Box 1260 D-84526 Tittmoning Germany www.rosenberger.de					Tel. : +49 8684 18-0 Email : info@rosenberger.de		Page 2 / 2