



The Future of Analog IC Technology®

MP4689A

100V Input, 1A,
High-Power LED Driver

DESCRIPTION

The MP4689A is a high-voltage input, step-down, switching regulator that delivers up to 1A of constant current to high-power LEDs. The MP4689A integrates a high-side, high-voltage, power MOSFET with a typical current limit of 3.5A.

The wide 4.5V to 100V input range accommodates a variety of step-down applications, making it ideal for automotive, industrial, and general lighting applications.

Hysteresis current-mode control is applied for very fast response, which makes the 20kHz dimming frequency possible. MPS's proprietary feedback control scheme minimizes the number of external components while delivering an LED current with $\pm 3\%$ accuracy.

The switching frequency is up to 1MHz, which allows for a small component size. Thermal shutdown and short-circuit protection (SCP) provide reliable and fault-tolerant operations. A $170\mu\text{A}$ quiescent current allows the MP4689A to be used in battery-powered applications.

The MP4689A is available in a SOIC-8 package with an exposed pad.

FEATURES

- Wide 4.5V to 100V Operating Input Range
- No Output Capacitor Required
- $\pm 3\%$ LED Current Accuracy
- Hysteretic Control: No Compensation
- Up to 1MHz Switching Frequency
- Up to 20kHz Dimming Frequency
- Dedicated PWM Dimming Control Input
- Short-Circuit Protection (SCP) with Integrated High-Side MOSFET
- Thermal Shutdown
- 200mV Reference Voltage for High Efficiency
- Up to 95% Efficiency
- $170\mu\text{A}$ Quiescent Current
- Available in a SOIC-8 Package with an Exposed Pad

APPLICATIONS

- High-Power LED Drivers
- Automotive, Industry, and General Lighting
- Constant Current Sources

All MPS parts are lead-free, halogen-free, and adhere to the RoHS directive. For MPS green status, please visit the MPS website under Quality Assurance. "MPS" and "The Future of Analog IC Technology" are registered trademarks of Monolithic Power Systems, Inc.

TYPICAL APPLICATION

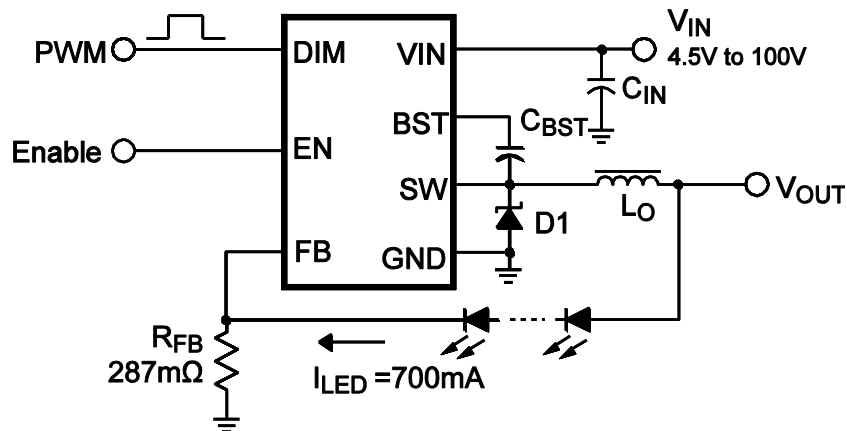

ORDERING INFORMATION

Part Number	Package	Top Marking
MP4689AGN	SOIC-8 EP	<i>See Below</i>

*For Tape & Reel, add suffix-Z (e.g. MP4689AGN-Z)

TOP MARKING

MP4689A
LLLLLLLL
MPSYWW

MP4689A: Part number
 LLLLLLLL: Lot number
 MPS: MPS prefix
 Y: Year code
 WW: Week code

PACKAGE REFERENCE

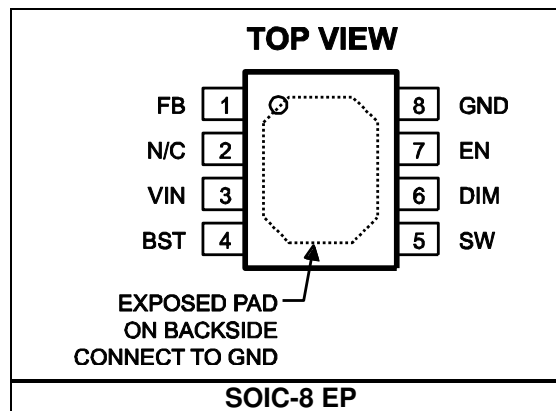

ABSOLUTE MAXIMUM RATINGS ⁽¹⁾

Supply voltage (VIN)	-0.3V to +100V
Switch voltage (V _{SW})	-0.5V to VIN + 0.5V
BST to SW	-0.3V to +6V
All other pins	-0.3V to +6V
Junction temperature	150°C
Continuous power dissipation (T _A = +25°C) ⁽²⁾2.5W
Lead temperature	260°C
Storage temperature	-65°C to +150°C

Recommended Operating Conditions ⁽³⁾

Supply voltage (VIN)	4.5V to 95V
EN and DIM voltages	0V to 5V
Operating junction temp.(T _J)	-40°C to +125°C

<i>Thermal Resistance</i> ⁽⁴⁾	θ_{JA}	θ_{JC}
SOIC-8 EP	50	10 ... °C/W

NOTES:

- 1) Exceeding these ratings may damage the device.
- 2) The maximum allowable power dissipation is a function of the maximum junction temperature T_J(MAX), the junction-to-ambient thermal resistance θ_{JA} , and the ambient temperature T_A. The maximum allowable continuous power dissipation at any ambient temperature is calculated by P_D(MAX)=(T_J(MAX)-T_A)/ θ_{JA} . Exceeding the maximum allowable power dissipation produces an excessive die temperature, causing the regulator to go into thermal shutdown. Internal thermal shutdown circuitry protects the device from permanent damage.
- 3) The device is not guaranteed to function outside of its operating conditions.
- 4) Measured on JESD51-7 4-layer board.

ELECTRICAL CHARACTERISTICS

Typical values are at $T_J = +25^{\circ}\text{C}$, unless otherwise noted. Minimum and maximum values are at $T_J = -40^{\circ}\text{C} \sim +125^{\circ}\text{C}$, unless otherwise noted. Guaranteed by characterization.

Parameter	Symbol	Condition	Min	Typ	Max	Units
VIN UVLO threshold			3.6	4.0	4.35	V
VIN UVLO hysteresis				0.4		V
Shutdown supply current		$V_{EN} = 0\text{V}$		2	15	μA
Quiescent supply current		No load, $V_{FB} = 250\text{mV}$		170	240	μA
Upper switch on resistance ⁽⁵⁾	$R_{DS(ON)}$	$V_{BST} - V_{SW} = 5\text{V}$		500		$\text{m}\Omega$
Upper switch leakage current	I_{SWLK}	$V_{EN} = 0\text{V}, V_{SW} = 0\text{V}$		0.01	1	μA
Current limit	I_{PK}	$V_{FB} = 0.15\text{V}$		3.5		A
EN up threshold	V_{ENH}		1.38	1.55	1.78	V
EN threshold hysteresis	V_{ENHY}			320		mV
EN input current	I_{ENI}	$V_{EN} = 5\text{V}$		0.01	1	μA
EN sinking current	I_{ENS}	$V_{EN} = 2\text{V}$		2	3	μA
DIM up threshold	V_{DIMH}		0.8	1.15	1.5	V
DIM threshold hysteresis	V_{DIMHY}			300		mV
DIM input current	I_{DIM}	$V_{DIM} = 5\text{V}$ or 0V	-1		1	μA
DIM on propagation delay ⁽⁵⁾	t_{DIMDH}	$V_{FB} = 0\text{V}, V_{DIM}$ rising edge to V_{SW} rising edge		50		ns
DIM off propagation delay ⁽⁵⁾	t_{DIMDL}	$V_{FB} = 0\text{V}, V_{DIM}$ falling edge to V_{SW} falling edge		50		ns
Feedback voltage threshold high ⁽⁵⁾	V_{FBH}	$4.5\text{V} < V_{IN} < 100\text{V}, V_{FB}$ rising from 0V until $V_{SW} < 30\text{V}$		215		mV
Feedback voltage threshold low ⁽⁵⁾	V_{FBL}	$4.5\text{V} < V_{IN} < 100\text{V}, V_{FB}$ falling from 0.25V until $V_{SW} > 30\text{V}$		185		mV
FB input current	I_{FB}	$V_{FB} = 5\text{V}$ or 0V	-300		300	nA
FB propagation delay to output high ⁽⁵⁾	t_{FBDH}	Falling edge of V_{FB} from 0.25V to 0V to V_{SW} rising edge		100		ns
FB propagation delay to output low ⁽⁵⁾	t_{FBDL}	Rising edge of V_{FB} from 0V to 0.25V to V_{SW} falling edge		100		ns
Thermal shutdown	T_{SD}	Hysteresis = 20°C		150		$^{\circ}\text{C}$

NOTE:

5) Guaranteed by design.

PIN FUNCTIONS

SOIC-8 EP Pin #	Name	Description
1	FB	Feedback. FB is the input to the hysteretic comparators. An external current sensing resistor is connected in series with the LEDs to GND. The feedback voltage is connected to FB and is regulated at +200mV with a 15% current ripple.
2	NC	No connection.
3	VIN	Input supply. VIN supplies power to all of the internal control circuitries, both BST regulators, and the high-side switch. A decoupling capacitor to ground must be placed close to VIN to minimize switching spikes.
4	BST	Bootstrap. BST is the positive power supply for the internal floating high-side MOSFET driver. Connect a bypass capacitor between BST and SW.
5	SW	Switch node. SW is the output from the high-side switch. A low V_F Schottky rectifier to ground is required. The rectifier must be close to SW to reduce switching spikes.
6	DIM	PWM dimming input. Pull DIM below the specified threshold for dimming off; pull DIM above the specified threshold for dimming on. If there is no need for the dimming function, connect DIM to EN.
7	EN	Enable input. Pull EN below the specified threshold to shut the chip down; pull EN above the specified threshold or leave EN floating to enable the chip.
8	GND, Exposed Pad	Ground. GND should be connected as close to the output capacitor as possible while avoiding the high-current switch paths. Connect the exposed pad to the GND plane for optimal thermal performance.

TYPICAL PERFORMANCE CHARACTERISTICS

$L = 47\mu\text{H}$, 1 LED Load, $T_A = 25^\circ\text{C}$, unless otherwise noted.

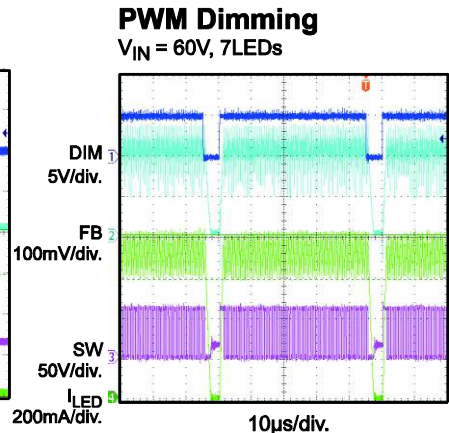
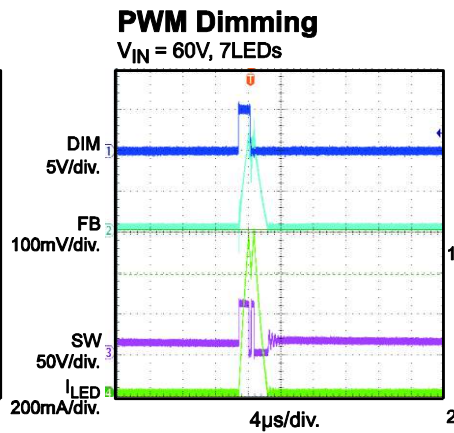
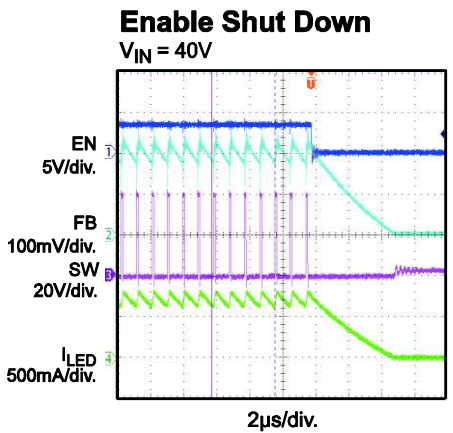
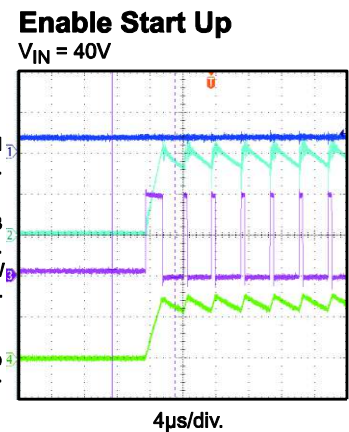
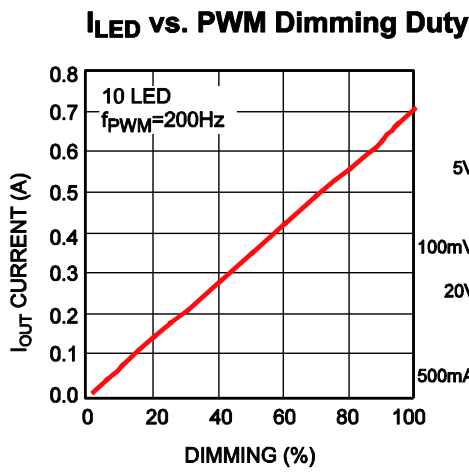
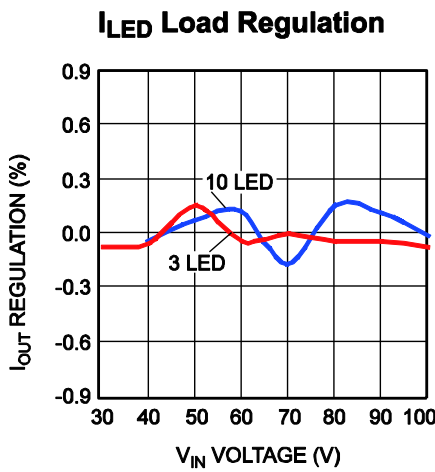
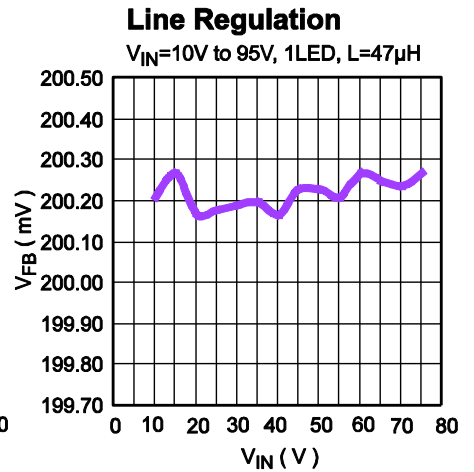
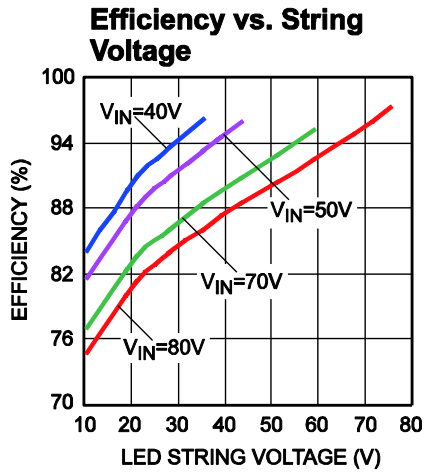
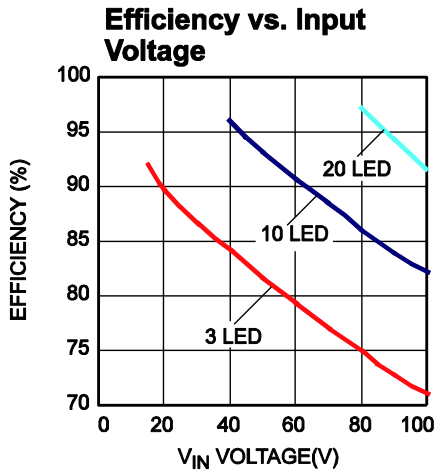

BLOCK DIAGRAM

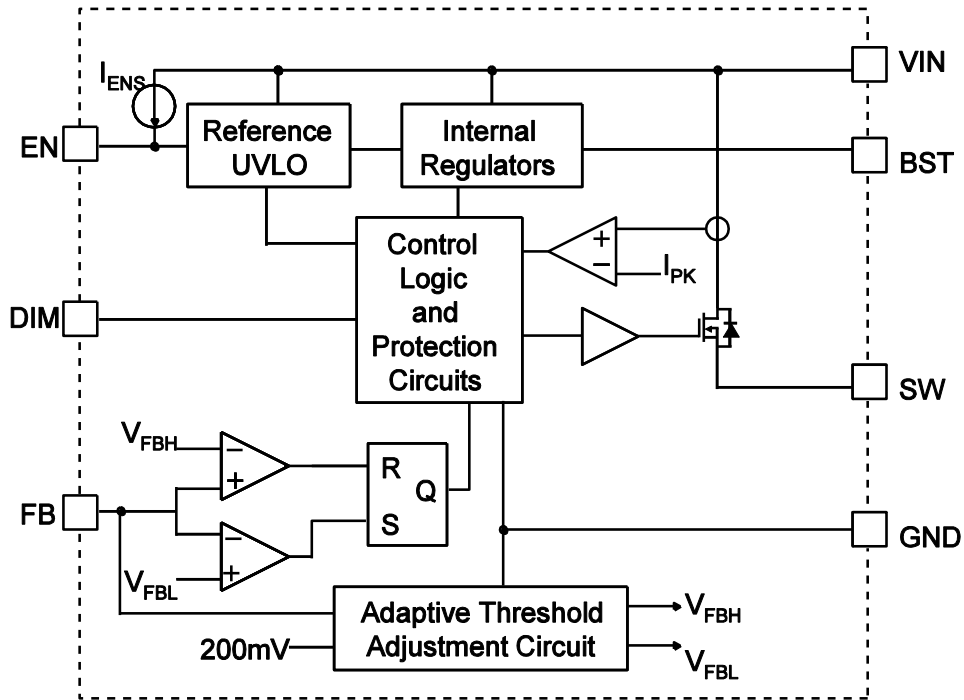

Figure 1: Functional Block Diagram

OPERATION

Hysteresis Current Control with Adaptive Threshold Adjustment

The MP4689A operates in hysteresis current control mode to regulate the LED current accurately. FB is the sensed voltage of the LED current across the sensing resistor. The power MOSFET is turned on and remains on until FB rises to 215mV. The power MOSFET is turned off and remains off until FB falls to 185mV. The two thresholds of 215mV and 185mV are adjusted adaptively to compensate for all circuit delays. Therefore, the LED current is regulated very accurately with a 200mV average value at FB.

Enable Control (EN)

The MP4689A has a dedicated enable control pin (EN) with positive logic. Its falling threshold is a precise 1.2V, and its rising threshold is 1.5V (300mV higher).

When floating, EN is pulled up to about 3.0V by an internal 1 μ A current source and is enabled. To pull EN down, a current capability over 1 μ A is needed.

Floating Driver and Bootstrap Charging

The floating power MOSFET driver is powered by an external bootstrap capacitor. This floating driver has its own UVLO protection. This UVLO's rising threshold is 2.2V with a hysteresis of 150mV.

The bootstrap capacitor is charged and regulated to about 5V by the dedicated internal bootstrap regulator.

In case the internal circuit does not have sufficient voltage and the bootstrap capacitor is not well charged, extra external circuitry can be used to ensure that the bootstrap voltage is in its normal operational region. Refer to the External Bootstrap Diode section on page 9 for details.

Under-Voltage Lockout (UVLO)

Under-voltage lockout (UVLO) is implemented to protect the chip from operating at an insufficient supply voltage. The UVLO rising threshold is about 4.0V, while its falling threshold is a consistent 3.65V.

Thermal Shutdown

Thermal shutdown is implemented to prevent the chip from operating at exceedingly high temperatures. When the silicon die temperature is higher than its upper threshold, the entire chip shuts down. When the temperature is lower than its lower threshold, the chip is enabled again.

LED Short Protection

The LED current is well-regulated with the FB voltage at 200mV. As long as the LED sensing resistor has not failed, the output current is within the limitation. If the LED sensing resistor has failed or the output is shorted to GND directly, the FB voltage is low, even if the power MOSFET is turned on. The power MOSFET shuts off if the failure time is longer than 10 μ s. The MP4689A attempts operation again after about 300 μ s.

The power MOSFET current is also accurately sensed via a current sense MOSFET. If the current is over 3.5A, the IC shuts down. This offers extra protection under output short conditions.

APPLICATION INFORMATION

Setting the LED Current

The LED current (I_{LED}) is set using a sensing resistor (R_{FB}), which is in series with the LEDs and connected to GND. The voltage on R_{FB} is connected to FB and can be calculated with Equation (1):

$$I_{LED} = \frac{V_{FB}}{R_{FB}} \quad (1)$$

For example, for a 700mA LED current, R_{FB} is 287mΩ.

Inductor Selection and Frequency Setting

The inductor (L_O) is required to supply a constant current to the LED. The inductor value is related to the switching frequency (f_s) setting, which can be calculated with Equation (2):

$$f_s = \frac{V_{OUT} \cdot (V_{IN} - V_{OUT})}{V_{IN} \cdot (8 \cdot 10^{-8} \cdot V_{IN} + L \cdot 15\% \cdot I_{LED})} \quad (2)$$

Where V_{IN} is the input voltage, and V_{OUT} is the output voltage to drive the LEDs. A larger-value inductor results in a smaller switching frequency. The peak inductor current can be calculated with Equation (3):

$$I_{LP} = I_{LED} \cdot \left(\frac{4 \cdot 10^{-8} \cdot V_{IN}}{L \cdot I_{LED}} + 1.075 \right) \quad (3)$$

Choose an inductor that will not saturate under the maximum inductor peak current and has a switching frequency under 2MHz.

Output Rectifier Diode

The output rectifier diode supplies current to the inductor when the high-side switch is off. To reduce losses due to the diode forward voltage and recovery times, use a Schottky diode.

The RMS current through the diode can be calculated with Equation (4):

$$I_D = I_{LED} \cdot \sqrt{1 - \frac{V_{OUT}}{V_{IN}}} \quad (4)$$

Choose a diode with a maximum reverse voltage rating greater than the maximum input voltage and a current rating greater than the maximum diode current.

Input Capacitor (C_{IN})

The input current to the step-down converter is discontinuous and therefore requires a capacitor to supply AC current to the step-down converter while maintaining the DC input voltage. Use low ESR capacitors for the best performance, especially for high switching frequency applications.

The RMS current through the input capacitor can be calculated with Equation (5):

$$I_D = I_{LED} \cdot \sqrt{\frac{V_{OUT}}{V_{IN}}} \quad (5)$$

With low ESR capacitors, estimate the input voltage ripple with Equation (6):

$$\Delta V_{IN} = \frac{I_{LED}}{f_s \times C_{IN}} \times \frac{V_{OUT}}{V_{IN}} \times \left(1 - \frac{V_{OUT}}{V_{IN}} \right) \quad (6)$$

Choose an input capacitor with enough RMS current rating and enough capacitance for small input voltage ripples.

When electrolytic or tantalum capacitors are applied, a small, high-quality ceramic capacitor (i.e.: 0.1μF) should be placed as close to the IC as possible.

Output Capacitor (C_{OUT})

The output capacitor (C_{OUT}) is not necessary for the MP4689A. The LED current ripple (peak-to-peak value) is about 15% of the LED DC current. An output capacitor can be used to reduce the LED current ripple further. Low ESR capacitors are recommended to keep the output voltage ripple low so that the AC ripple current through the LEDs is small. The output voltage ripple can be estimated with Equation (7):

$$\Delta V_{OUT} = \frac{V_{OUT}}{f_s \times L_O} \times \left(1 - \frac{V_{OUT}}{V_{IN}} \right) \times \left(R_{ESR} + \frac{1}{8 \times f_s \times C_{OUT}} \right) \quad (7)$$

Where R_{ESR} is the equivalent series resistance (ESR) value of the output capacitor.

External Bootstrap Diode

An external bootstrap diode may enhance the efficiency of the LED driver (see Figure 2). An external BST diode is recommended from the floating driver power to BST in the following cases:

- There is a 5V rail available in the system.
- V_{IN} is no greater than 5V.
- V_{OUT} is between 3.3V and 5V.

This diode is also recommended for high duty cycle operation (when $V_{OUT} / V_{IN} > 65\%$) and very high frequency (over 1.5MHz) applications.

The bootstrap diode can be a low-cost one, such as IN4148 or BAT54.

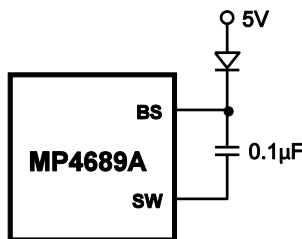

Figure 2: External Bootstrap Diode

PCB Layout Recommendation

It is essential to place the input decoupling capacitor, catch diode, and the MP4689A (V_{IN} , SW, and PGND) as close to each other as possible with very short and fairly wide traces. This helps reduce the voltage spike on the SW node greatly and lowers EMI noise level. For best results, follow the guidelines below.

1. Run the feedback trace as far from the inductor and noisy power traces as possible.
2. Run the feedback trace on the side of the PCB opposite of the inductor with a ground plane separating the two.
3. Create a grid of thermal vias right under the exposed pad to help improve thermal conduction.
4. Use small vias (15mil barrel diameter) so that the hole is essentially filled up during the plating process, aiding conduction to the other side.

A hole that is too large can cause solder wicking problems during the reflow soldering process. The pitch (distance between the centers) of several such thermal vias in an area is typically 40mil.

PACKAGE INFORMATION

SOIC-8 EP

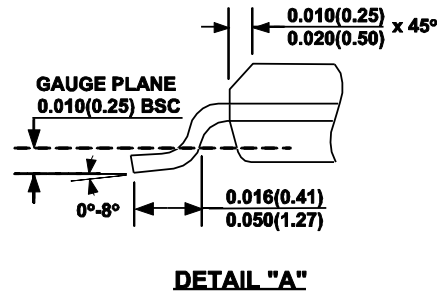
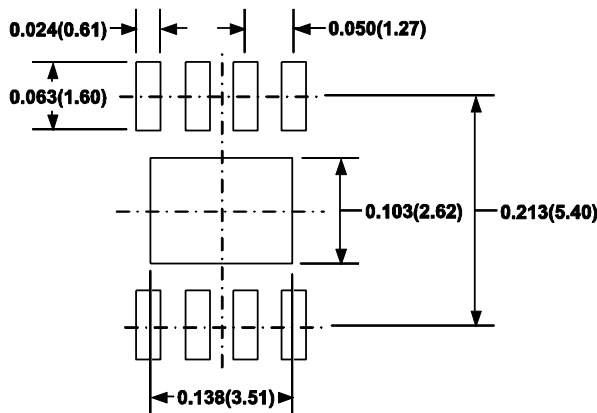
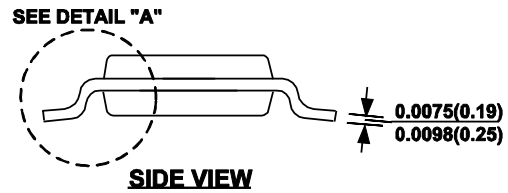
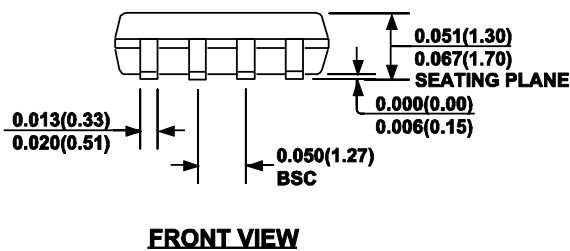
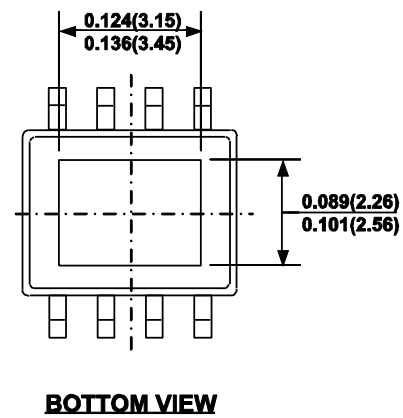
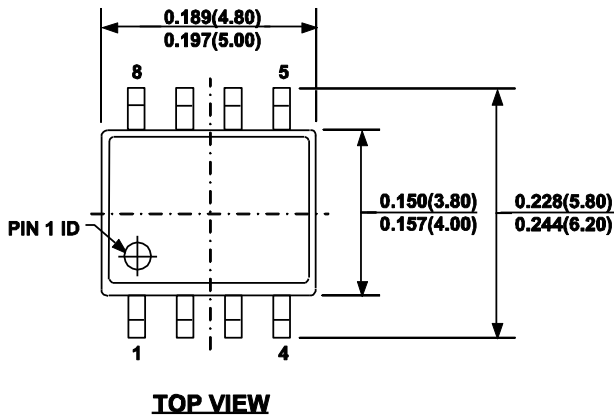

NOTE:

- 1) CONTROL DIMENSION IS IN INCHES. DIMENSION IN BRACKET IS IN MILLIMETERS.
- 2) PACKAGE LENGTH DOES NOT INCLUDE MOLD FLASH, PROTRUSIONS OR GATE BURRS.
- 3) PACKAGE WIDTH DOES NOT INCLUDE INTERLEAD FLASH OR PROTRUSIONS.
- 4) LEAD COPLANARITY (BOTTOM OF LEADS AFTER FORMING) SHALL BE 0.004" INCHES MAX.
- 5) DRAWING CONFORMS TO JEDEC MS-012, VARIATION BA.
- 6) DRAWING IS NOT TO SCALE.

NOTICE: The information in this document is subject to change without notice. Users should warrant and guarantee that third party Intellectual Property rights are not infringed upon when integrating MPS products into any application. MPS will not assume any legal responsibility for any said applications.