

# HiPerFAST™ IGBT

**IXGH 28N90B**  
**IXGT 28N90B**

$V_{CES} = 900 \text{ V}$   
 $I_{C25} = 51 \text{ A}$   
 $V_{CE(SAT)} = 2.7 \text{ V}$   
 $t_{fi(typ)} = 130 \text{ ns}$

Preliminary data sheet

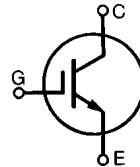

Symbol	Test Conditions	Maximum Ratings
$V_{CES}$	$T_J = 25^\circ\text{C to } 150^\circ\text{C}$	900 V
$V_{CGR}$	$T_J = 25^\circ\text{C to } 150^\circ\text{C}; R_{GE} = 1 \text{ M}\Omega$	900 V
$V_{GES}$	Continuous	$\pm 20 \text{ V}$
$V_{GEM}$	Transient	$\pm 30 \text{ V}$
$I_{C25}$	$T_C = 25^\circ\text{C}$	51 A
$I_{C110}$	$T_C = 110^\circ\text{C}$	28 A
$I_{CM}$	$T_C = 25^\circ\text{C}, 1 \text{ ms}$	120 A
<b>SSOA (RBSOA)</b>	$V_{GE} = 15 \text{ V}, T_{VJ} = 125^\circ\text{C}, R_G = 10 \Omega$ Clamped inductive load, $L = 100 \mu\text{H}$	$I_{CM} = 56 \text{ A}$ @ $0.8 V_{CES}$
$P_C$	$T_C = 25^\circ\text{C}$	200 W
$T_J$		$-55 \dots +150 \text{ }^\circ\text{C}$
$T_{JM}$		150 $^\circ\text{C}$
$T_{stg}$		$-55 \dots +150 \text{ }^\circ\text{C}$
Maximum lead temperature for soldering 1.6 mm (0.062 in.) from case for 10 s		300 $^\circ\text{C}$
$M_d$	Mounting torque (M3)	1.13/10Nm/lb.in.
<b>Weight</b>	TO-247 AD	6 g
	TO-247 SMD	4 g

**TO-247 AD (IXGH)**

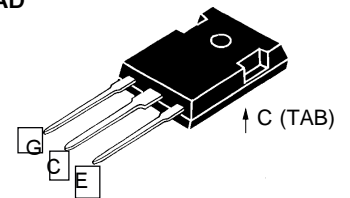

**TO-268 (D3) (IXGT)**

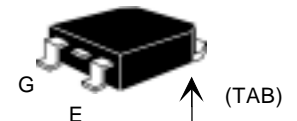

G = Gate,  
E = Emitter,  
C = Collector,  
TAB = Collector

### Features

- International standard packages JEDEC TO-268 surface mountable and JEDEC TO-247 AD
- High current handling capability
- Latest generation HDMOS™ process
- MOS Gate turn-on - drive simplicity

### Applications

- AC motor speed control
- DC servo and robot drives
- DC choppers
- Uninterruptible power supplies (UPS)
- Switched-mode and resonant-mode power supplies

### Advantages

- Space savings (two devices in one package)
- High power density
- Suitable for surface mounting
- Switching speed for high frequency applications
- Easy to mount with 1 screw, TO-247 (isolated mounting screw hole)

Symbol	Test Conditions	Characteristic Values ( $T_J = 25^\circ\text{C}$ , unless otherwise specified)		
		min.	typ.	max.
$BV_{CES}$	$I_C = 250 \mu\text{A}, V_{GE} = 0 \text{ V}$	900		V
$V_{GE(th)}$	$I_C = 250 \mu\text{A}, V_{CE} = V_{GE}$	2.5		5 V
$I_{CES}$	$V_{CE} = V_{CES}, V_{GE} = 0 \text{ V}$			500 $\mu\text{A}$ 5 mA
$I_{GES}$	$V_{CE} = 0 \text{ V}, V_{GE} = \pm 20 \text{ V}$			$\pm 100 \text{ nA}$
$V_{CE(sat)}$	$I_C = I_{C110}, V_{GE} = 15 \text{ V}$	2.2	2.7	V

Symbol	Test Conditions	Characteristic Values ( $T_j = 25^\circ\text{C}$ , unless otherwise specified)		
		min.	typ.	max.
$g_{fs}$	$I_C = I_{C110}$ ; $V_{CE} = 10\text{ V}$ , Pulse test, $t \leq 300\ \mu\text{s}$ , duty cycle $\leq 2\%$	20	32	S
$C_{ies}$ $C_{oes}$ $C_{res}$	$V_{CE} = 25\text{ V}$ , $V_{GE} = 0\text{ V}$ , $f = 1\text{ MHz}$		3200	pF
			160	pF
			32	pF
$Q_g$ $Q_{ge}$ $Q_{gc}$	$I_C = I_{C110}$ ; $V_{GE} = 15\text{ V}$ , $V_{CE} = 0.5 V_{CES}$		100	150 nC
			18	28 nC
			40	70 nC
$t_{d(on)}$ $t_{ri}$ $t_{d(off)}$ $t_{fi}$ $E_{off}$	<b>Inductive load, <math>T_j = 25^\circ\text{C}</math></b> $I_C = I_{C110}$ ; $V_{GE} = 15\text{ V}$ $V_{CE} = 0.8 V_{CES}$ ; $R_G = R_{off} = 4.7\ \Omega$ Remarks: Switching times may increase for $V_{CE}$ (Clamp) $> 0.8 \cdot V_{CES}$ , higher $T_j$ or increased $R_G$		30	ns
			30	ns
			100	170 ns
			130	220 ns
			1.2	2 mJ
$t_{d(on)}$ $t_{ri}$ $E_{on}$ $t_{d(off)}$ $t_{fi}$ $E_{off}$	<b>Inductive load, <math>T_j = 125^\circ\text{C}</math></b> $I_C = I_{C110}$ ; $V_{GE} = 15\text{ V}$ $V_{CE} = 0.8 V_{CES}$ ; $R_G = R_{off} = 4.7\ \Omega$ Remarks: Switching times may increase for $V_{CE}$ (Clamp) $> 0.8 \cdot V_{CES}$ , higher $T_j$ or increased $R_G$		30	ns
			35	ns
			0.3	mJ
			280	ns
			190	ns
			2.5	mJ
$R_{thJC}$ $R_{thCK}$	TO-247			0.62 KW KW

### Min Recommended Footprint

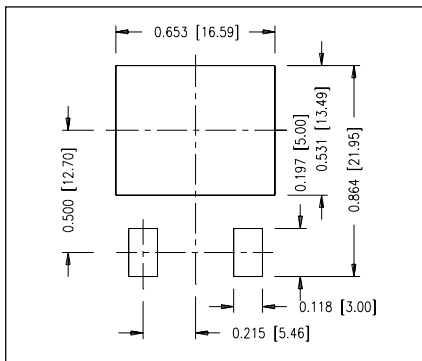

### TO-247 AD Outline

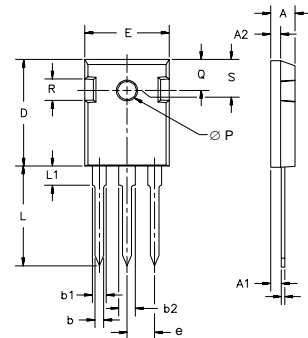

Dim.	Millimeter		Inches	
	Min.	Max.	Min.	Max.
A	4.7	5.3	.185	.209
A <sub>1</sub>	2.2	2.54	.087	.102
A <sub>2</sub>	2.2	2.6	.059	.098
b	1.0	1.4	.040	.055
b <sub>1</sub>	1.65	2.13	.065	.084
b <sub>2</sub>	2.87	3.12	.113	.123
C	.4	.8	.016	.031
D	20.80	21.46	.819	.845
E	15.75	16.26	.610	.640
e	5.20	5.72	0.205	0.225
L	19.81	20.32	.780	.800
L <sub>1</sub>		4.50		.177
∅P	3.55	3.65	.140	.144
Q	5.89	6.40	0.232	0.252
R	4.32	5.49	.170	.216
S	6.15	BSC	242	BSC

### TO-268 Outline

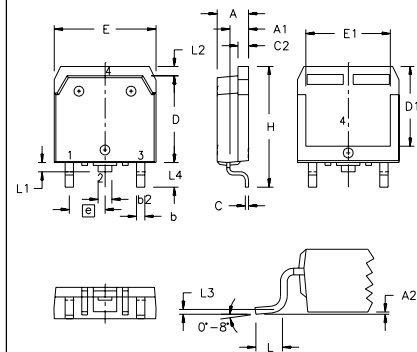

SYM	INCHES		MILLIMETERS	
	MIN	MAX	MIN	MAX
A	.193	.201	4.90	5.10
A <sub>1</sub>	.106	.114	2.70	2.90
A <sub>2</sub>	.001	.010	0.02	0.25
b	.045	.057	1.15	1.45
b <sub>2</sub>	.075	.083	1.90	2.10
C	.016	.026	0.40	0.65
C <sub>2</sub>	.057	.063	1.45	1.60
D	.543	.551	13.80	14.00
D <sub>1</sub>	.488	.500	12.40	12.70
E	.624	.632	15.85	16.05
E <sub>1</sub>	.524	.535	13.30	13.60
e	.215	BSC	5.45	BSC
H	.736	.752	18.70	19.10
L	.094	.106	2.40	2.70
L <sub>1</sub>	.047	.055	1.20	1.40
L <sub>2</sub>	.039	.045	1.00	1.15
L <sub>3</sub>	.010	BSC	0.25	BSC
L <sub>4</sub>	.150	.161	3.80	4.10

IXYS reserves the right to change limits, test conditions, and dimensions.

IXYS MOSFETS and IGBTs are covered by one or more of the following U.S. patents: 4,835,592 4,881,106 5,017,508 5,049,961 5,187,117 5,486,715  
4,850,072 4,931,844 5,034,796 5,063,307 5,237,481 5,381,025