

ADS5263EVM Evaluation Module

This user's guide gives an overview of the ADS5263EVM and describes how the evaluation module can be used to evaluate the performance, functions, and features of the ADS5263 device.

Contents

1	Quick Look at the Evaluation Setup	2
2	EVM Circuit Description	3
2.1	Power	3
2.2	Clock Input	3
2.3	Analog Input	4
2.4	Onboard Band-Pass Filter in THS Path	5
3	ADS5263EVM GUI	6
3.1	Installing the EVM GUI	6
3.2	GUI Features	8
4	TSW1400 GUI	10
4.1	Verify the Setup	10
4.2	Verify the Ramp Test Pattern	13
4.3	Verify With a Sine Wave Analog Input	15
5	ADS5263EVM Schematics and Test Points	16
5.1	List of Test Points	16
6	ADS5263EVM PCB Layout	16
7	Bill of Materials	23
Appendix A	High Speed Data Converter Pro (HSDCPro) GUI Installation	25

List of Figures

1	Evaluation Setup	2
2	ADS5263 Sine Wave Clocking Using Transformer	3
3	ADS5263 Clocking Using a LVPECL Buffer	4
4	Input Drive Circuit – Using Transformers	4
5	Input Drive Circuit – Using THS770006 Amplifier	5
6	Band-Pass Filter	6
7	ADS5263 GUI	9
8	ADS5263 GUI	10
9	EVM and TSW Card Connections	11
10	Initializing the ADS5263GUI	12
11	Successful Interface Between TSW Card and Computer	13
12	Enabling Ramp Test Pattern in the ADS5263 GUI	14
13	Verifying With Ramp Test Pattern	15
14	Spectrum of Captured Data	16
15	ADS5263EVM Top Layer Assembly Drawing – Top View	17
16	ADS5263EVM Bottom Layer Assembly Drawing – Bottom View	18
17	ADS5263EVM Top Layer Copper – Top View	19
18	ADS5263EVM Internal Layer 1, Ground – Top View	20
19	ADS5263EVM Internal Layer 2, Power – Top View	21
20	ADS5263EVM Bottom Layer Copper – Top View	22

21	HSDCPro Install (Begin).....	25
22	HSDCPro Install (Install Directory).....	26
23	HSDCPro Install (TI License Agreement).....	27
24	HSDCPro Install (NI License Agreement).....	28
25	HSDCPro Install (Start Installation).....	29
26	HSDCPro Install (Installation Progress).....	30
27	HSDCPro Install (Installation Complete).....	31
28	HSDCPro Install (h).....	32
29	HSDCPro Install.....	32

List of Tables

1	Two-Input Configurations.....	5
2	SMT Resistors.....	5
3	EVM Components List.....	23

1 Quick Look at the Evaluation Setup

Figure 1 shows an overview of the evaluation setup that includes the ADS5263EVM evaluation module (EVM), TSW1400 capture card, external equipment, and software requirements.

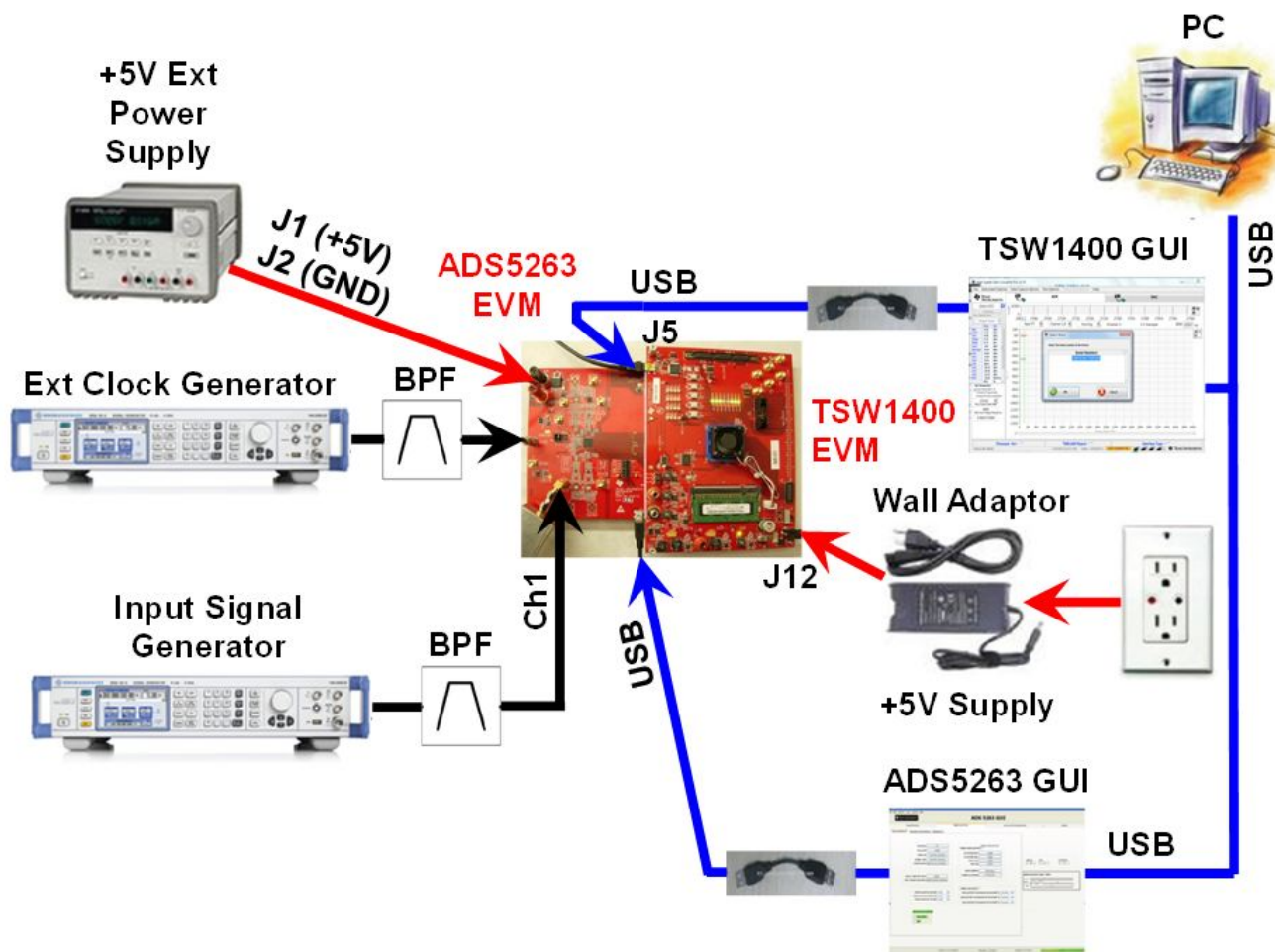

Figure 1. Evaluation Setup

TSW1400 Capture Card: The high-speed LVDS deserializer card is required for capturing data from the ADS5263EVM and its analysis using the TSW1400 graphical user interface (GUI).

For information pertaining to the TSW1400 card, see <http://www.ti.com/tool/tsw1400evm>.

Equipment: Signal generators (with low-phase noise) must be used as source of input signal and clock in order to get the desired performance. Additionally, band-pass filters are required in both the signal and clock paths to attenuate the harmonics and noise from the generators.

Power Supply: A single 5-V supply powers the EVM. The supplies for the ADS5263 device are derived from the 5-V supply. The power supply must be able to source up to 1.5 A. A 6-V supply can power the TSW1400 card using a laptop-style adapter.

USB Interface to PC: The USB connection from the ADS5263EVM and TSW1400 card to the personal computer (PC) must be set up; Step 3 in [Section 3.1](#) explains the USB driver installation.

ADS5263EVM GUI: [Section 3.1](#) explains the GUI installation procedure and its operation.

2 EVM Circuit Description

The complete schematic of the EVM can be found at the end of this user guide. Critical portions of the EVM are explained in the following text.

2.1 Power

The EVM requires a single 5-V supply for operation that can be supplied through banana jacks. Separate LDOs convert the 5-V input to generate the 3.3-V AVDD supply and the 1.8-V LVDD supply required for the ADS5263 operation.

2.2 Clock Input

The clock can be supplied to the analog-to-digital converter (ADC) in one of two ways. The default factory-configured option supplies a single-ended sine wave clock directly to the SMA connector J31. This clock is converted to differential by the TC4-1W transformer from MiniCircuits and is ac coupled to the ADC. This transformer has an impedance ratio of 4, so the voltage applied on J31 is stepped up by a factor of 2.

The clock input must be from a clean, low-jitter source (such as SMA100A or 8644B) and filtered by a narrow band-pass filter. Taking into account the attenuation of the filter, the clock amplitude must be set appropriately to get about 1.5-V peak-to-peak at the clock pins of the ADS5263.

The clock source is commonly synchronized with the signal generator of the input frequency to keep the clock and input coherent for meaningful FFT analysis.

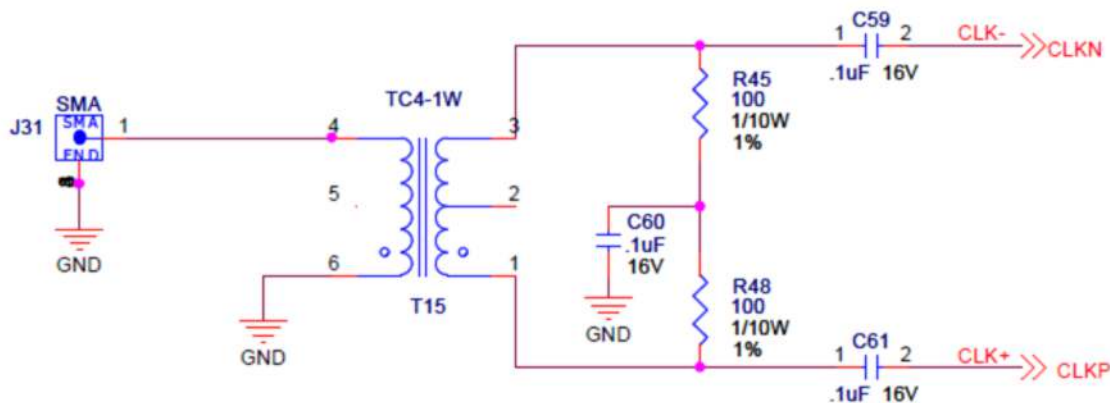

Figure 2. ADS5263 Sine Wave Clocking Using Transformer

LVPECL Clock Option

Alternately, the clock may be supplied by an onboard LVPECL clock buffer (TI's CDCLVP1102). To use this option,

- Remove the coupling capacitors C59, C61.
- Replace the 0-Ω resistors with 0.1-μF capacitors.
- Apply a single-ended, square-wave clock signal on SMA connector J33.

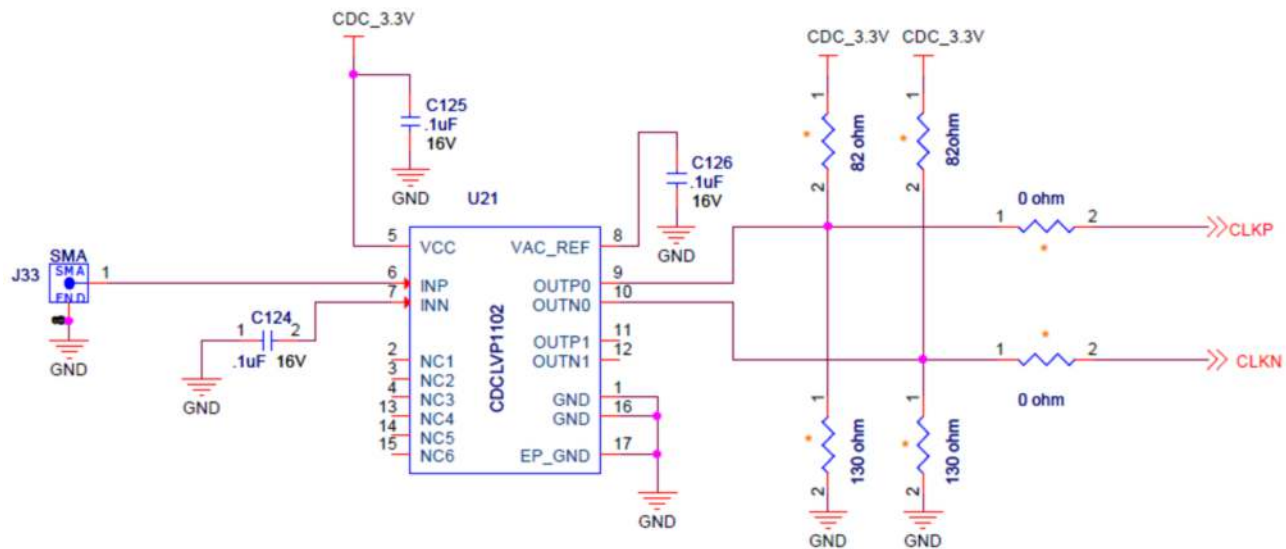

Figure 3. ADS5263 Clocking Using a LVPECL Buffer

2.3 Analog Input

The ADS5263 can be used as a quad-channel, 16-bit ADC or as a quad-channel, 14-bit ADC. Each channel can be configured to use either a transformer-coupled input or a TH77006 amplifier input, from a single-ended source. As a result, two input configurations exist detailed in [Table 1](#).

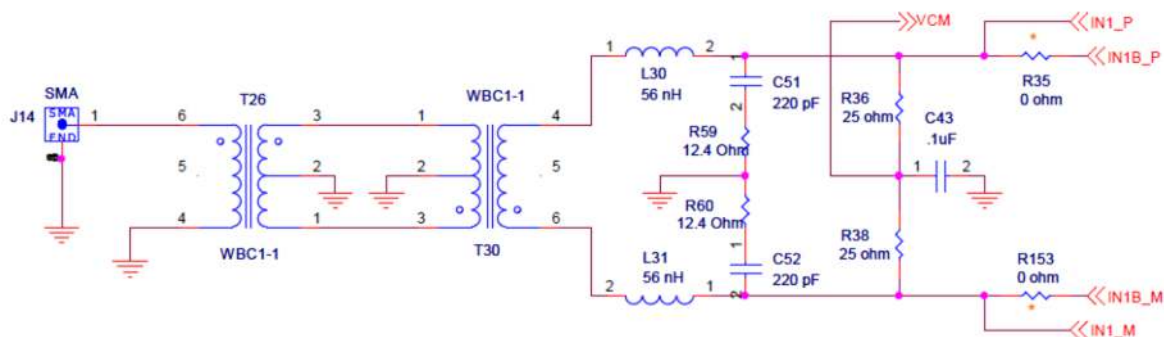

Figure 4. Input Drive Circuit – Using Transformers

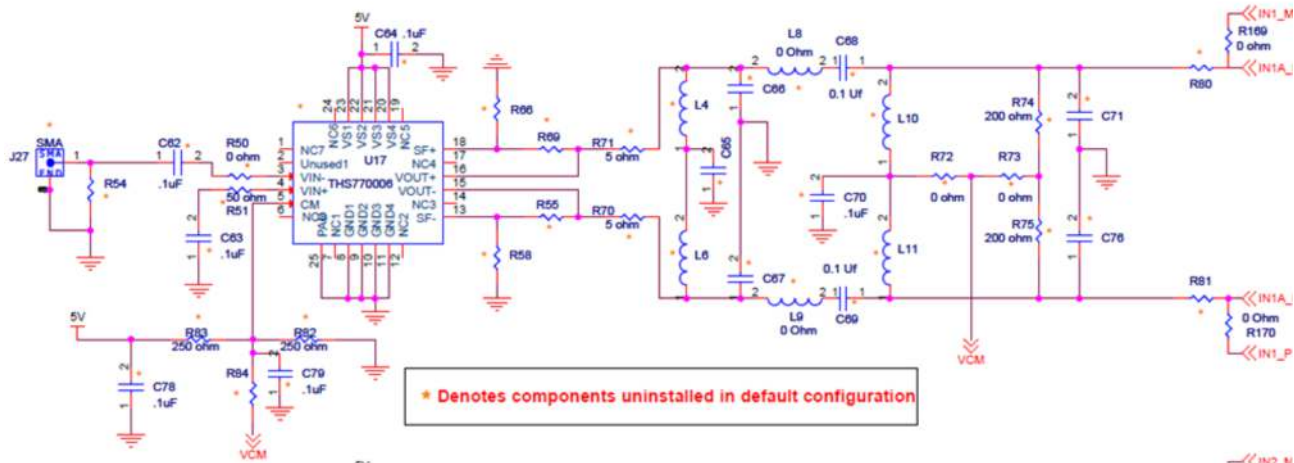

Figure 5. Input Drive Circuit – Using THS770006 Amplifier

Table 1. Two-Input Configurations

EVM Config	Transformer Drive	THS770006 Drive	Description
1	On channels 1, 2, 3, 4	On channel 3	<ul style="list-style-type: none"> All components in the transformer drive path for all four channels are available in the EVM. All components in the THS path for only channel 3 is available in the EVM.
2	On channels 1, 2, 3, 4	On channels 1, 2, 3, 4	<ul style="list-style-type: none"> All components in the transformer and THS paths for all four channels are available in the EVM.

Note that the 16-bit ADC and the 14-bit ADC have different analog input pins. Analog input pins 1A, 2A, 3A, 4A correspond to the 16-bit ADC inputs while 1B, 2B, 3B, 4B correspond to the 14-bit ADC inputs. Each of the four transformer paths can be configured to drive either the 16-bit or 14-bit ADC inputs. Similarly, each of the four THS paths can be configured to drive either the 16-bit or 14-bit ADC inputs. This configuration is achieved using pairs of 0 Ω SMT resistors, as listed in Table 2.

Table 2. SMT Resistors

Drive Type	Chan 1A 16-Bit ADC	Chan 1B 14-Bit ADC	Chan 2A 16-Bit ADC	Chan 2B 14-Bit ADC
Transformer	R80, R81 = Open R169, R170 = 0 Ω R35, R153 = Open	R169, R170 = Open R35, R153 = 0 Ω	R98, R99 = Open R171, R172 = 0 Ω R154, R155 = Open	R171, R172 = Open R154, R155 = 0 Ω
THS770006	R80, R81 = 0 Ω R169, R170 = Open	This option is not supported	R98, R99 = 0 Ω R171, R172 = Open	This option is not supported
Drive Type	Chan 3A 16-Bit ADC	Chan 3B 14-Bit ADC	Chan 4A 16-Bit ADC	Chan 4B 14-Bit ADC
Transformer	R138, R139 = Open R173, R174 = 0 Ω R165, R166 = Open	R173, R174 = Open R165, R166 = 0 Ω	R125, R126 = Open R175, R176 = 0 Ω R167, R168 = Open	R175, R176 = Open R167, R168 = 0 Ω
THS770006	R138, R139 = 0 Ω R173, R174 = Open	This option is not supported	R125, R126 = 0 Ω R175, R176 = Open	This option is not supported

2.4 Onboard Band-Pass Filter in THS Path

A provision exists in the EVM to include a band-pass filter in the analog input between the THS770006 amplifier and the ADS5263 input pins. Component placeholders are provided to support up to sixth-order LC band-pass filter on each of the four channels. This allows users to design their own filters, populate the EVM with the corresponding components, and verify the performance on the EVM itself.

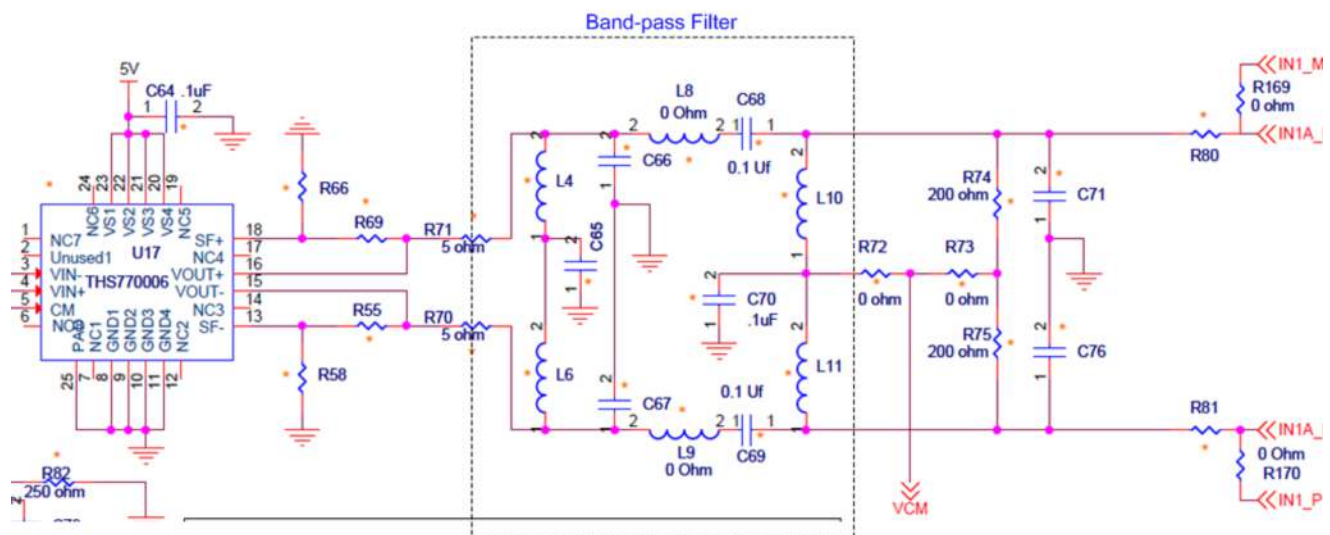
Figure 6. Band-Pass Filter

3 ADS5263EVM GUI

This section describes the software features accompanying the EVM kit. The ADS5263EVM control software allows users to write to the ADC registers found in the data sheet.

3.1 Installing the EVM GUI

The ADS5263EVM comes with a software install. To Download the software, visit the ADS5263 [product folder](#) under *Tools & software*.

Step 1 – Install the software before plugging in the USB cable for the first time.

- Unzip the installer file, and run the setup.exe file

Step 2 – Connect the USB cable from the PC to the EVM.

- If the USB driver has not been previously installed in the PC, then a Windows™ message *Found New Hardware* appears. Proceed to Step 3 to complete the installation.
- If the message does not appear, then skip Step 3

Step 3 – Completing the USB Driver Installation

- In the Found New Hardware message, select *No, not this time* from the options, and press the Next button



- Select *Install from a list or specific location (Advanced)* as shown in the following illustration, and then click *Next*.

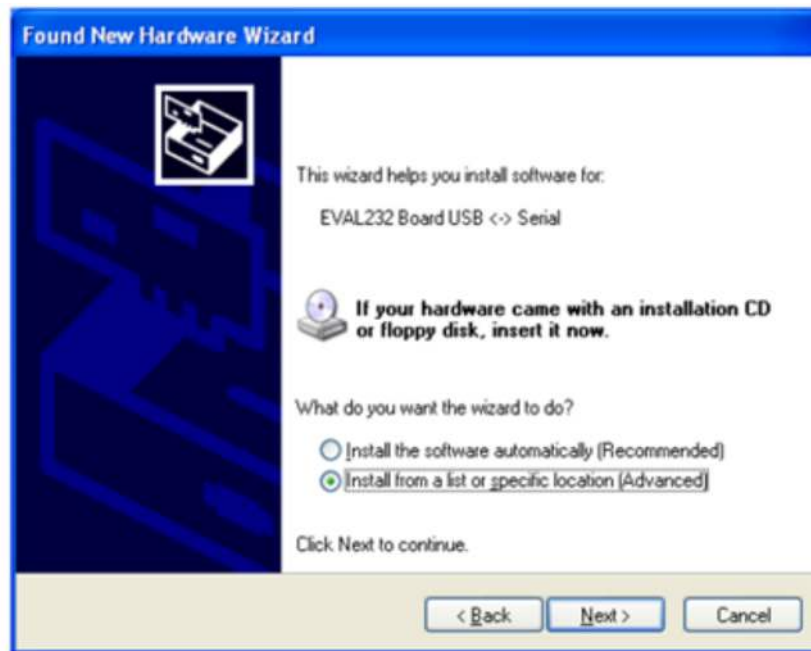

- Select *Search for the best driver in these locations.*, and enter the file path *C:\Program Files\Texas Instruments\CDM 2.04.06 WHQL Certified* in the combo-box, or browse to it by clicking the *Browse* button. Once the file path has been entered in the box, click *Next* to proceed.

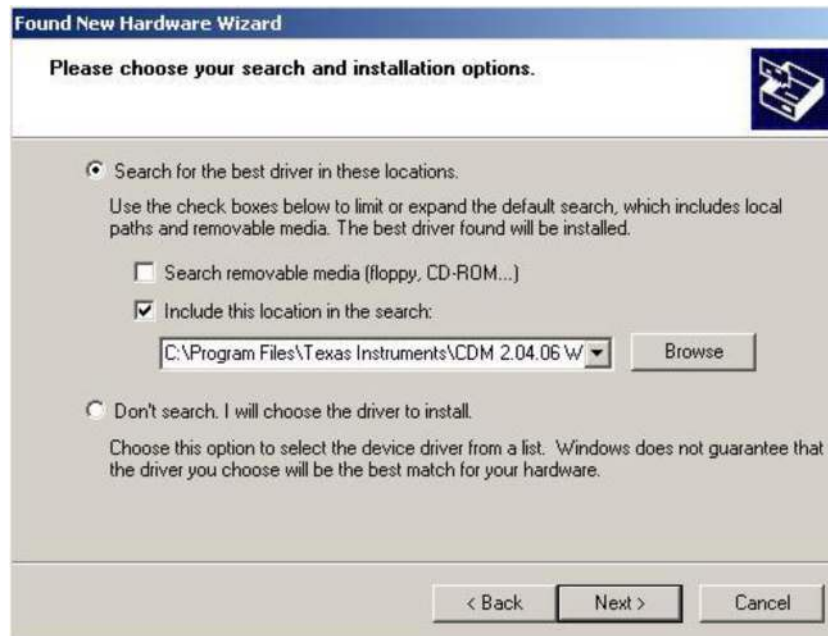

- Windows XP can be configured to warn when unsigned (non-WHQL certified) drivers are about to be installed. In that case, the following screen is displayed. Click on *Continue Anyway* to continue with the installation.



- If Windows XP is configured to ignore file signature warnings, no message appears.

3.2 GUI Features

Once it is launched, the ADS5263 GUI comes up in the state shown in the following illustration. The ADS5263 has many programmable registers to control various modes. In the GUI, registers with similar functions are grouped into separate tabs such as:

- Top-level
- Interface
- Dig Sig Proc

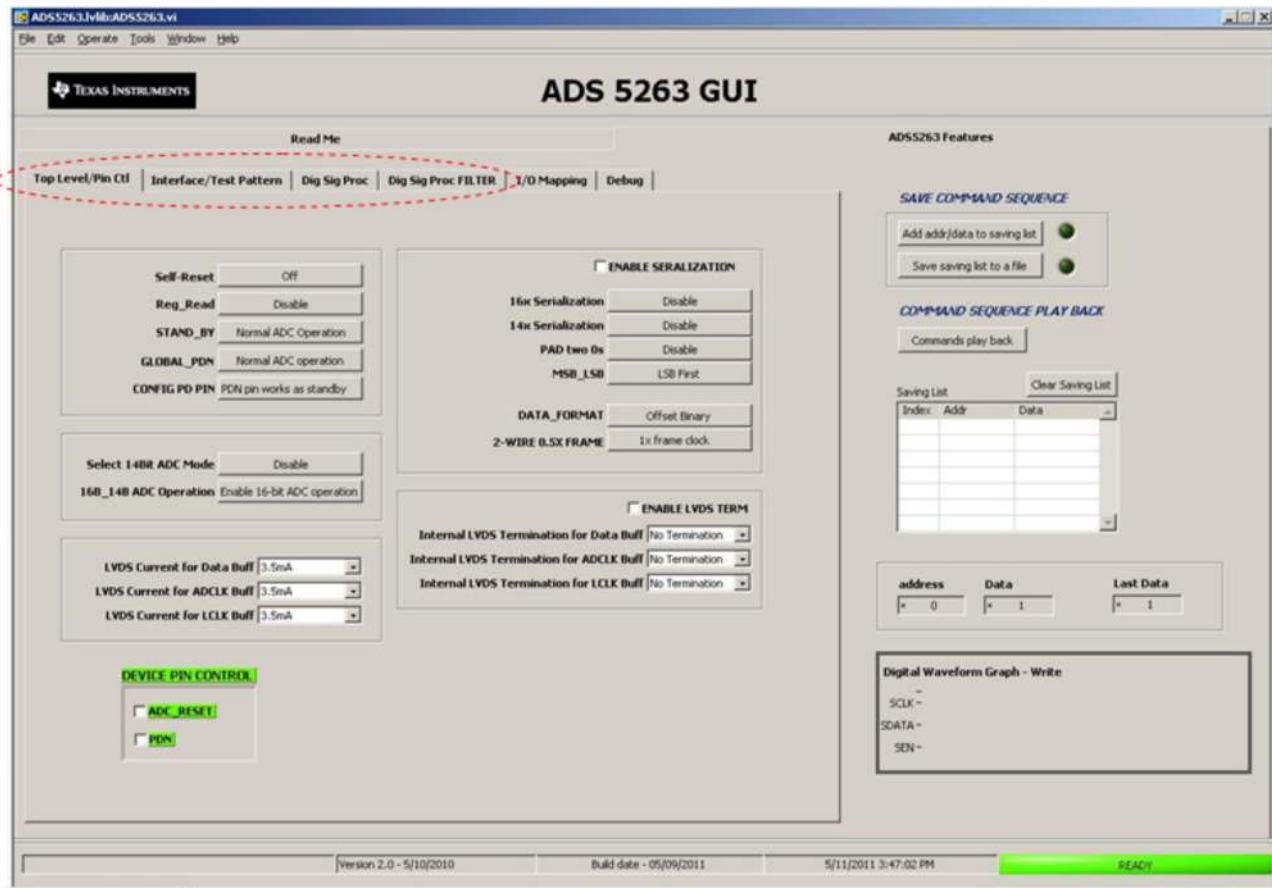

Figure 7. ADS5263 GUI

Additionally, the GUI has a couple of interesting features – debug mode and command sequence. The debug mode is an alternate way of controlling the registers in the device by directly specifying the hexadecimal values for the register address and register data.

The command sequence can be used to record and store a sequence of register writes into a text file. The next time, after a device reset, the text file can be simply played back. The GUI configures the device with the registers stored in the text file.

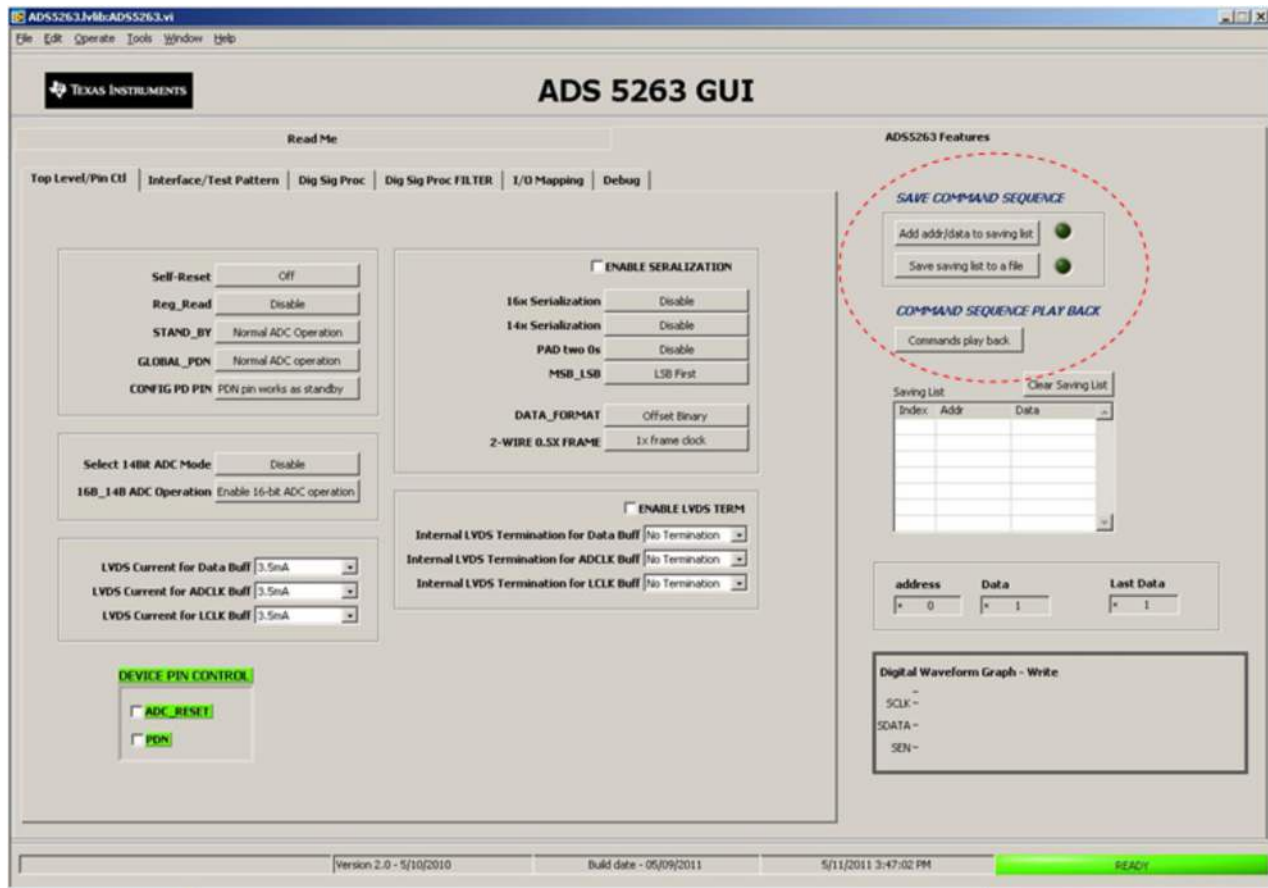

Figure 8. ADS5263 GUI

4 TSW1400 GUI

The TSW1400 GUI is required to transfer ADC data from the TSW1400 card. The data can be viewed in the time-domain. The spectrum of the captured data can be viewed in the Single Tone FFT tab.

For installation of the TSW GUI, see *TSW1400EVM: High-Speed LVDS Deserializer and Analysis System user's guide*. Also see [Appendix A](#) for how to download the software.

If the PC is already pre-installed with TSW1400, it may be an earlier revision that does not support the ADS5263 device. Follow the steps outlined in the relevant section of the TSW1400EVM user's guide to *first uninstall* and then re-install the latest TSW1400 version.

4.1 Verify the Setup

Perform the following steps before launching the TSW1400 GUI:

- Connect the TSW1400 card to the ADS5263EVM.
- Connect the power supplies to both cards and power up.
- Connect the USB cables from the PC to the ADS EVM and TSW card.

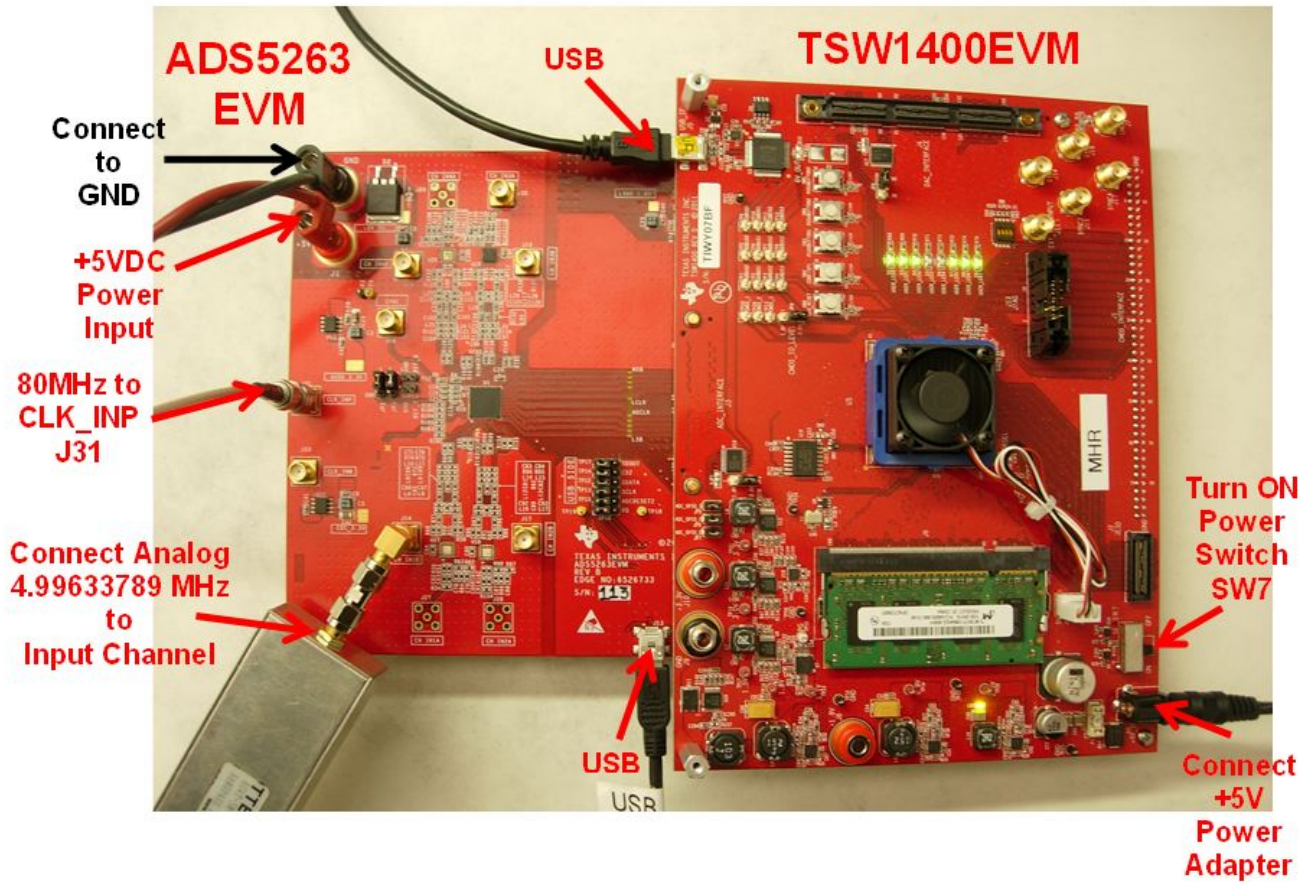

Figure 9. EVM and TSW Card Connections

- Launch the ADS5263GUI, and initialize the device
 - First, reset the device by clicking the *Self-reset* button (this is a self-clearing bit that resets the device and clears itself to zero)
 - Put device in 2-wire, ...modes

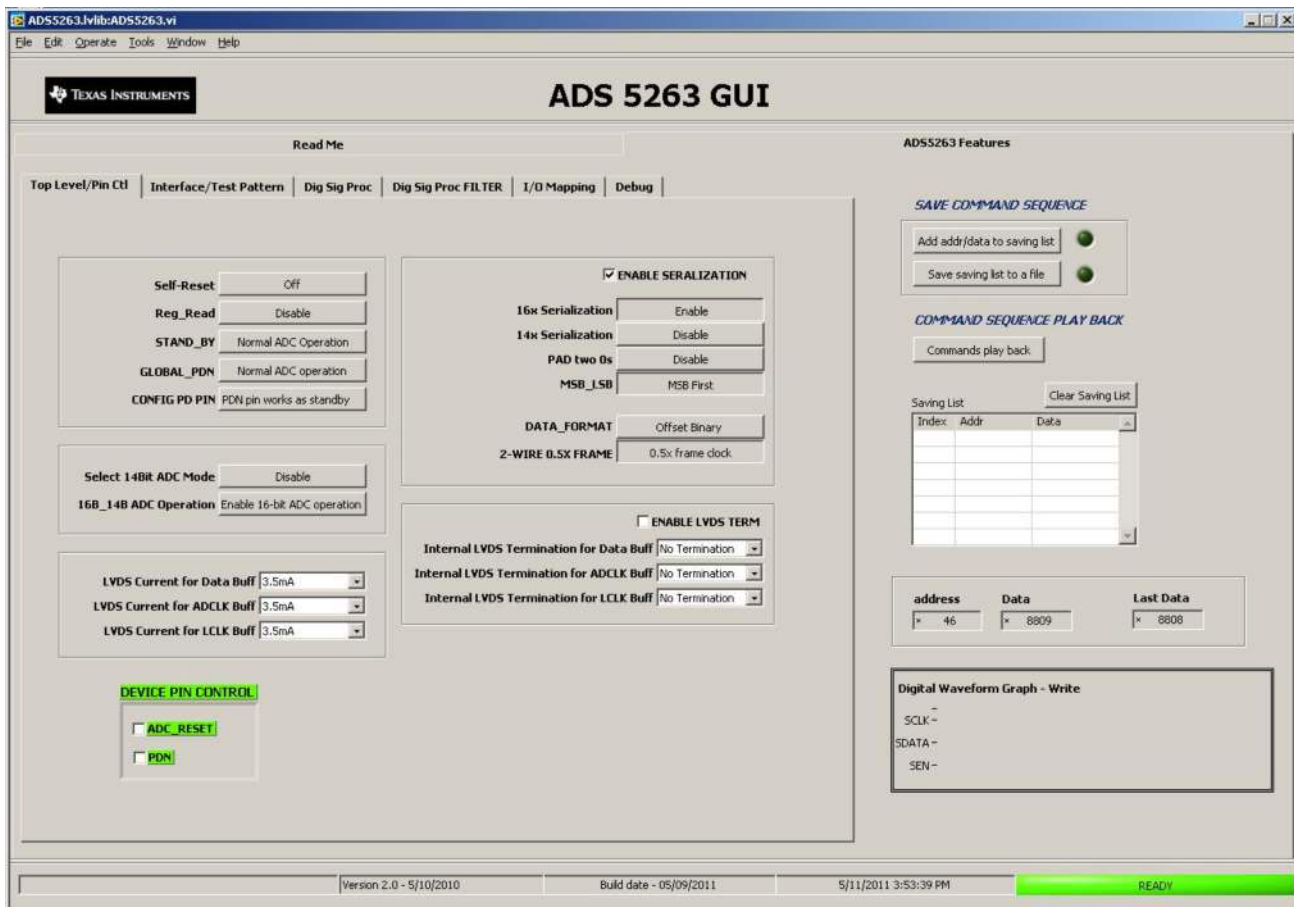

Figure 10. Initializing the ADS5263GUI

- Apply input clock signal to SMA connector J31.
- The device is now ready for data capture by the TSW card.
 - Check the DCM LED on the TSW card – it must be flashing. This indicates that the TSW card is able to correctly detect the bit clock output from the ADS EVM.
- Launch the TSW GUI; at this point, the TSW GUI communicates with the EVM and once proper communication is established, a message is displayed at the bottom left of the GUI.
- This completes the setup verification.

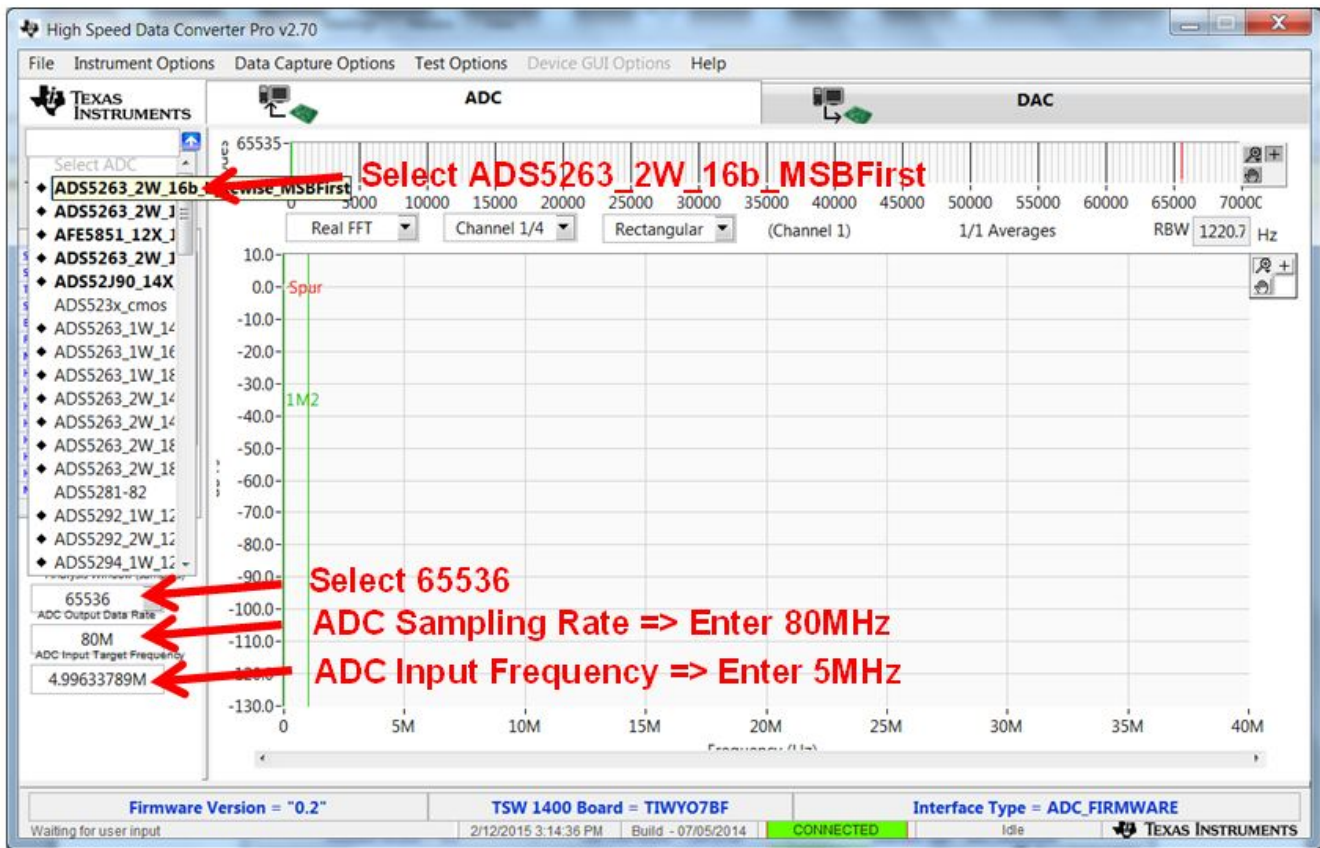

Figure 11. Successful Interface Between TSW Card and Computer

4.2 Verify the Ramp Test Pattern

- Initialize the TSW GUI with the following settings.
 - Select the device.
 - Choose the channel.
 - Enter the ADC sample rate. For example, *80M* for 80-MSPS sample rate.
- Using the ADS5263 GUI, enable the Ramp Test Pattern mode

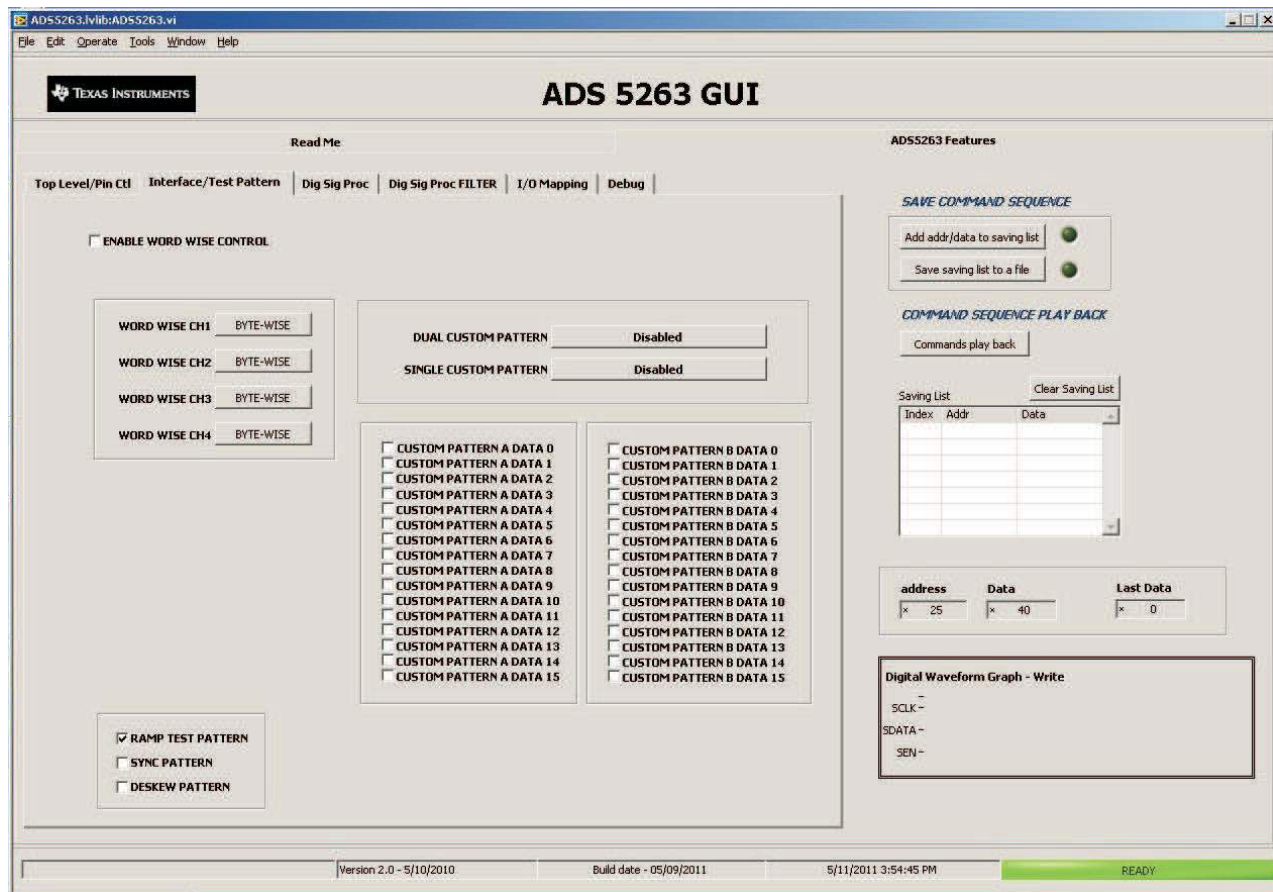

Figure 12. Enabling Ramp Test Pattern in the ADS5263 GUI

- Press the Capture button in the TSW GUI.
- Time Domain:
 - Select the Time Domain tab in the GUI.
 - Graph shows the captured time domain data.
It Must be a clean digital ramp that increases from code 0 to code 65535 from one sample to the next. Note that the starting code in the capture graph is not fixed and can be anywhere from 0 to 65535.

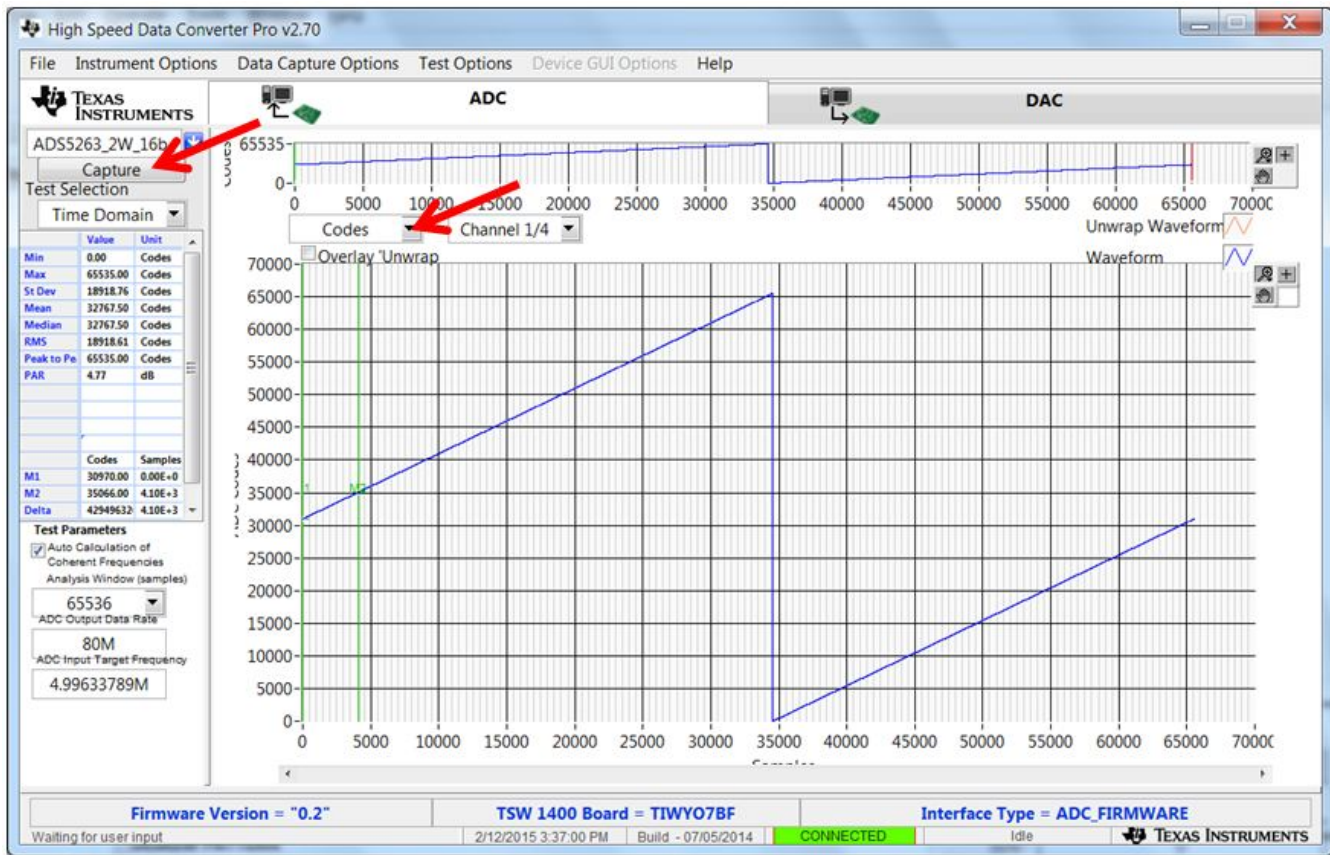

Figure 13. Verifying With Ramp Test Pattern

- Now, disable the *Ramp Test Pattern* in the ADS5263 GUI.
- This completes the verification of the ramp test pattern.

4.3 Verify With a Sine Wave Analog Input

- Note that for all performance evaluation, low-phase noise signal generators are required (see Figure 1) for both analog signal and sampling clock inputs.
- In the TSW GUI,
 - Enter the ADC input frequency being applied. For example, *3M* for 3-MHz input frequency.
 - choose the desired channel
- Set the frequency in the signal generator to the value displayed in the field *ADC Input Coherent frequency* and connect the generator output to the desired channel. This makes the input signal coherent with respect to the sampling clock, which is required for FFT analysis.
- Now, press the Capture button
- Frequency Domain:
 - Select the Single tone FFT tab in the GUI.
 - The fft graph shows the spectrum of the captured sine wave data

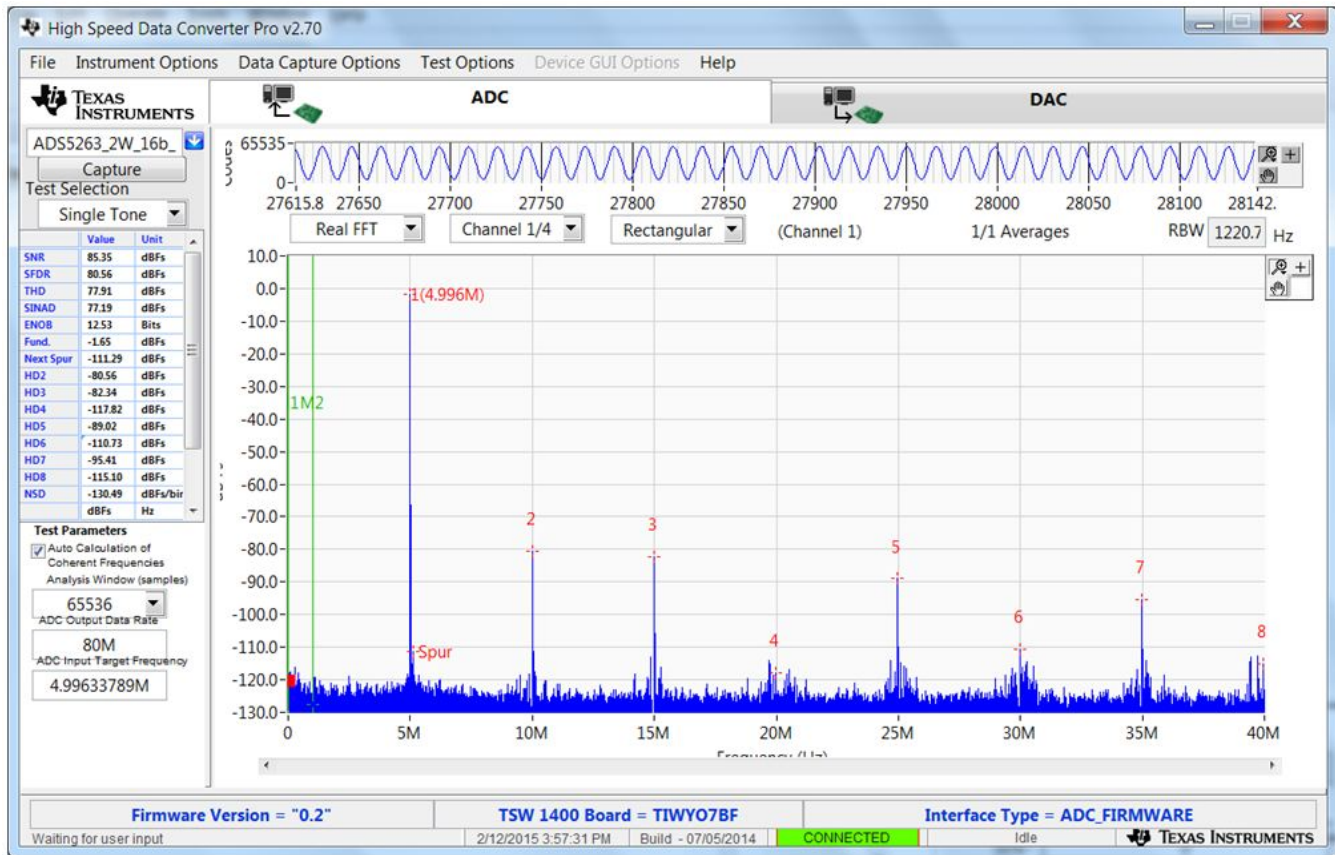

Figure 14. Spectrum of Captured Data

5 ADS5263EVM Schematics and Test Points

The schematics for the ADS5263EVM evaluation module are attached at the end of this document.

5.1 List of Test Points

Test Points on the EVM

Test Points	Name	Description
TP1	SDOUT	Serial register output
TP2	Ground	Board ground
TP9	VCM	1.5V common-mode output
TP12	SDATA	Serial interface data input
TP13	SCLK	Serial interface clock input
TP14	CSZ	Serial interface enable input
TP15	ADCRESETZ	Reset input
TP16	PD	Power down control input

6 ADS5263EVM PCB Layout

The following figures (Figure 15 through Figure 20) show the design of the ADS5263EVM printed-circuit board. PCB dimensions: L x W = 5 x 6 inches, four layers and 0.5-oz copper on outer layers and 1oz copper on inner layers.

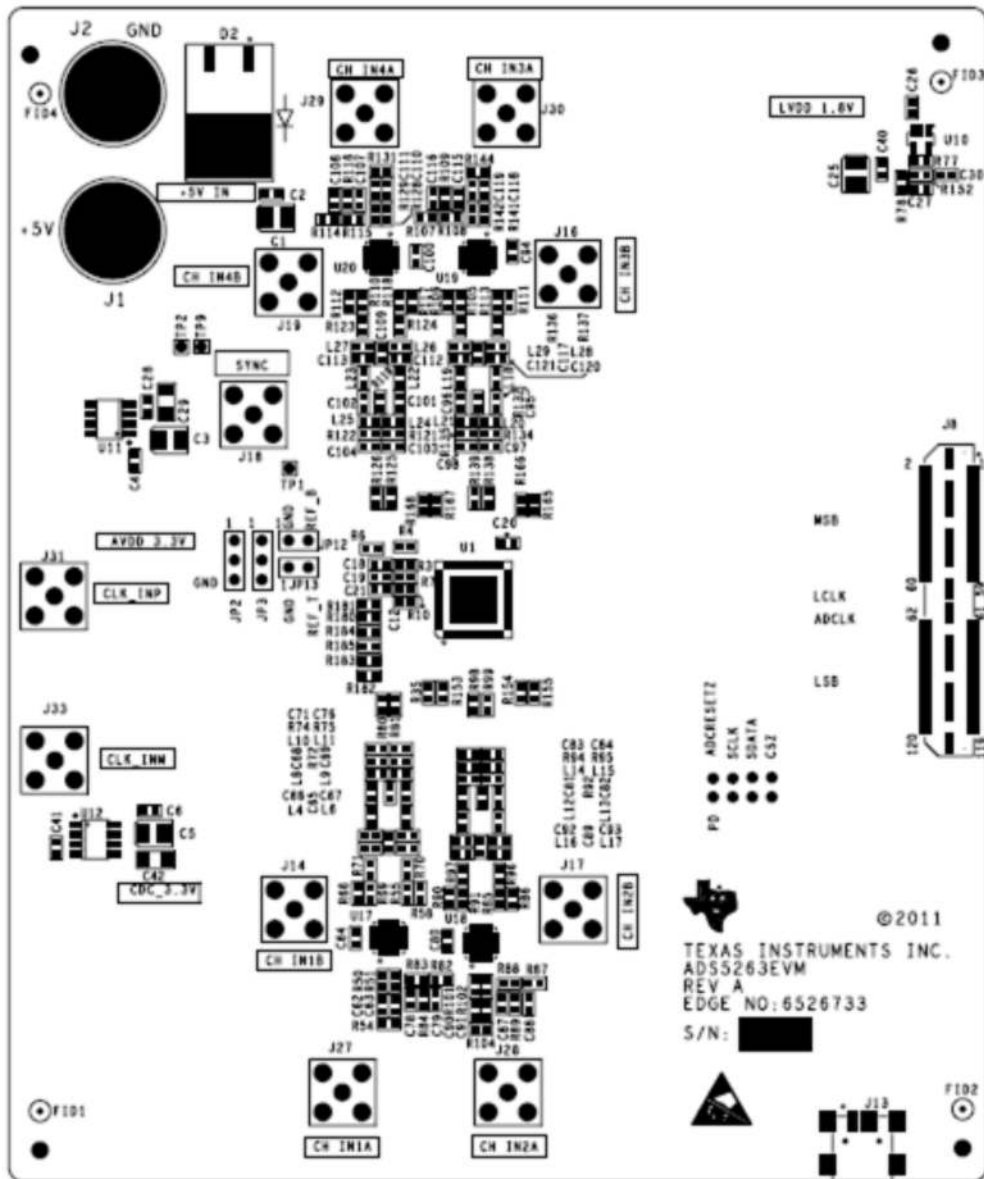

Figure 15. ADS5263EVM Top Layer Assembly Drawing – Top View

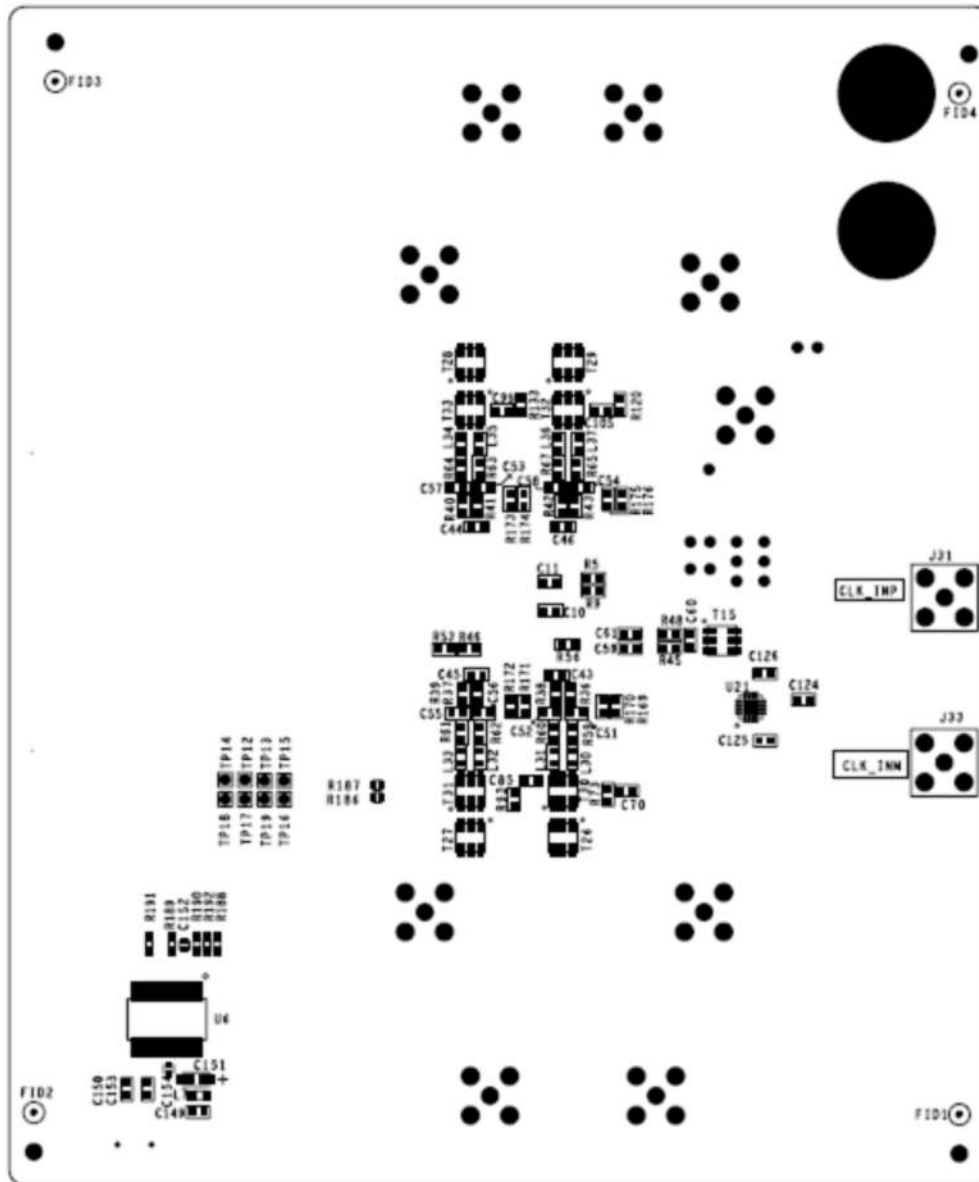

Figure 16. ADS5263EVM Bottom Layer Assembly Drawing – Bottom View

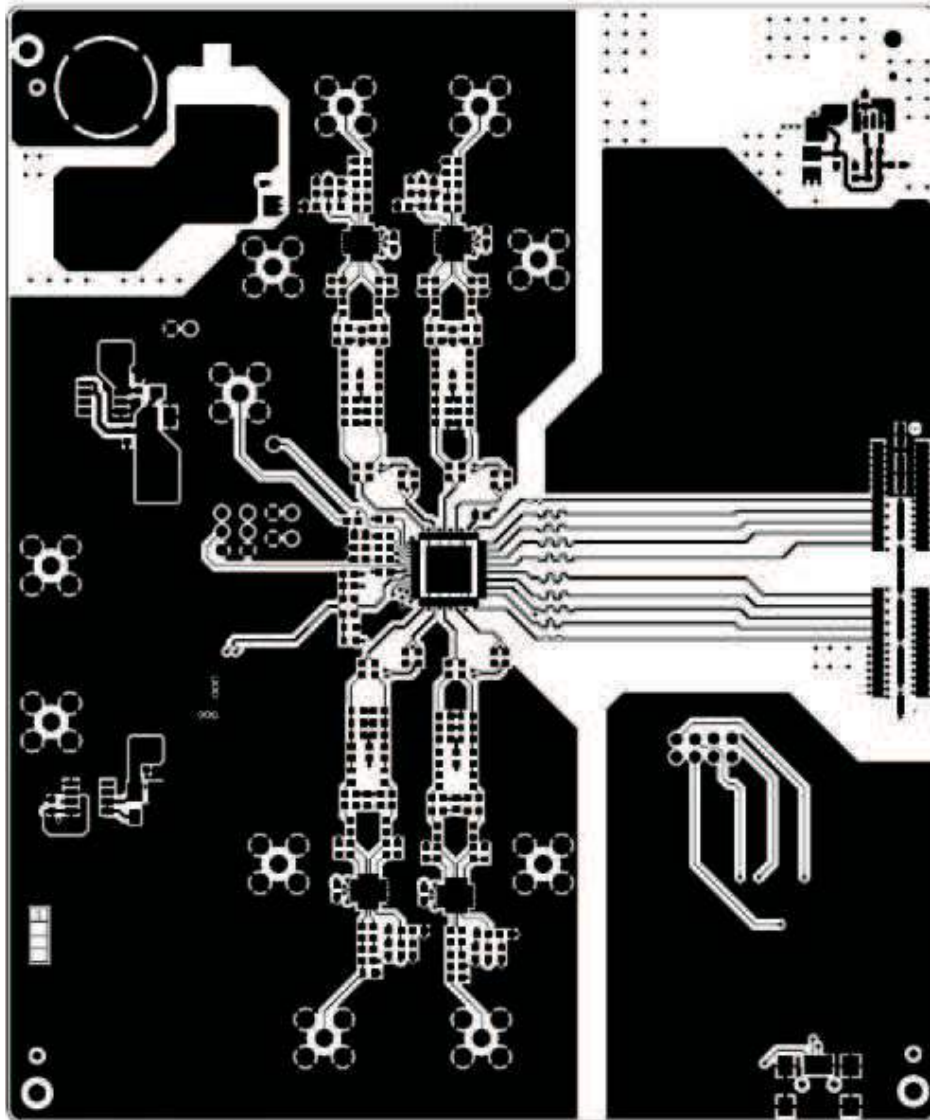

Figure 17. ADS5263EVM Top Layer Copper – Top View

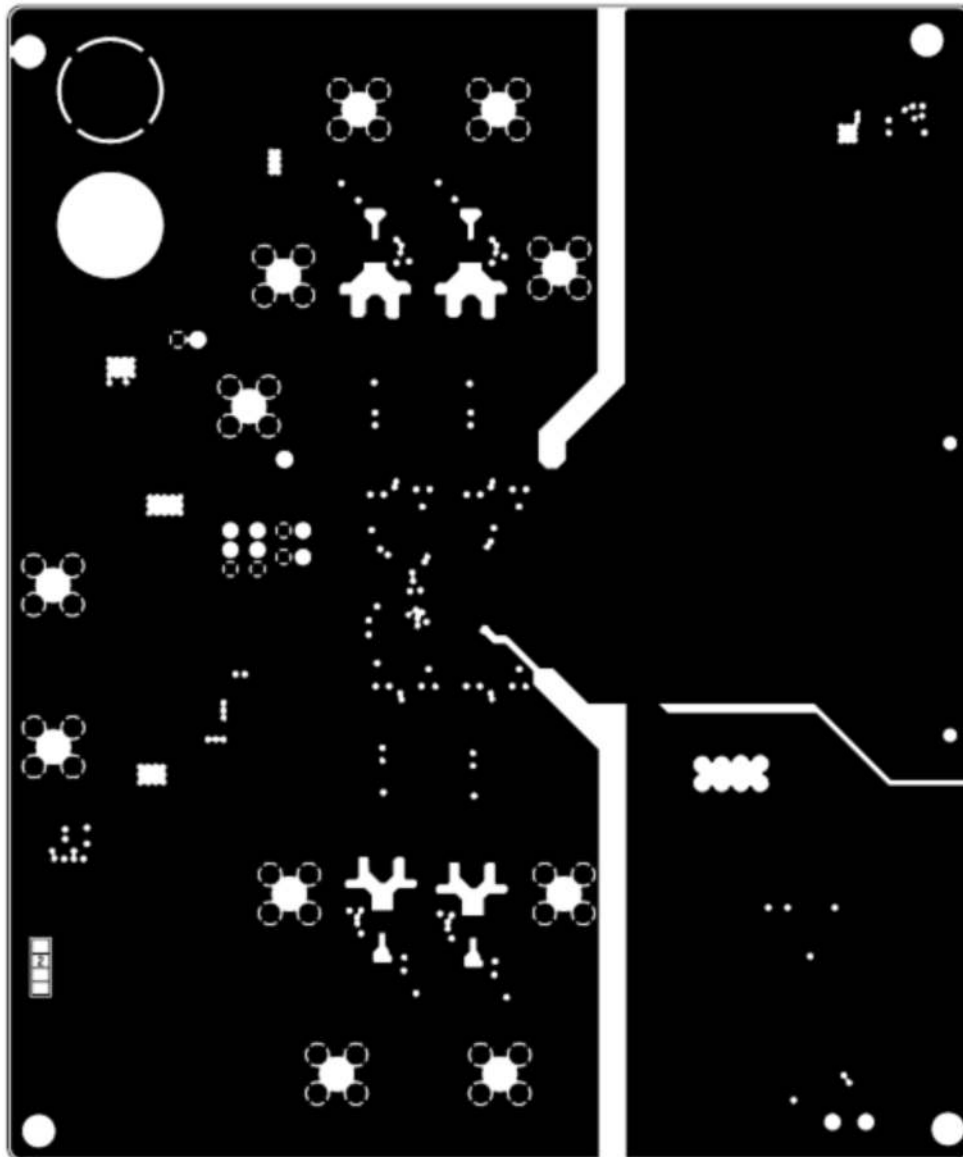

Figure 18. ADS5263EVM Internal Layer 1, Ground – Top View

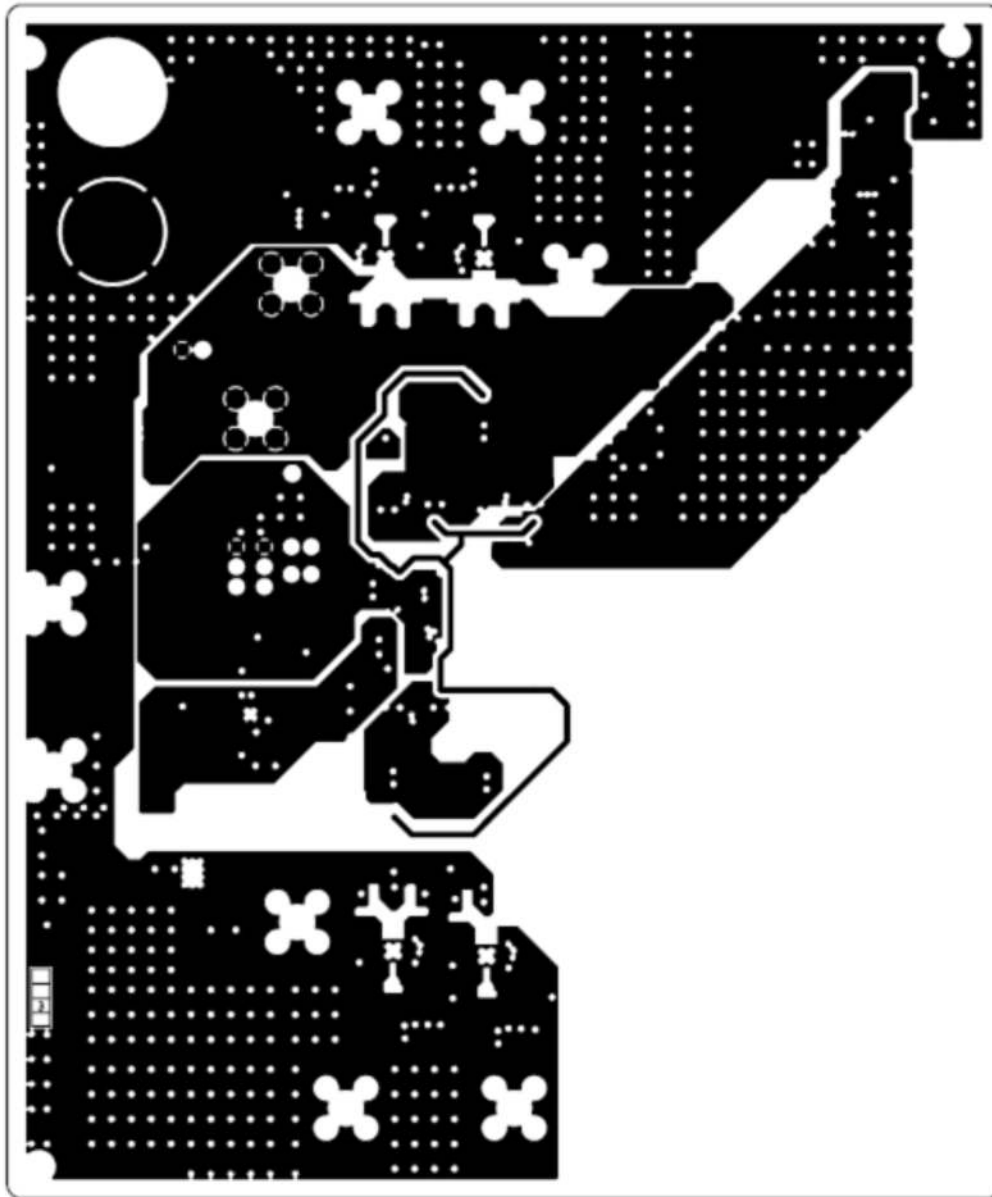

Figure 19. ADS5263EVM Internal Layer 2, Power – Top View

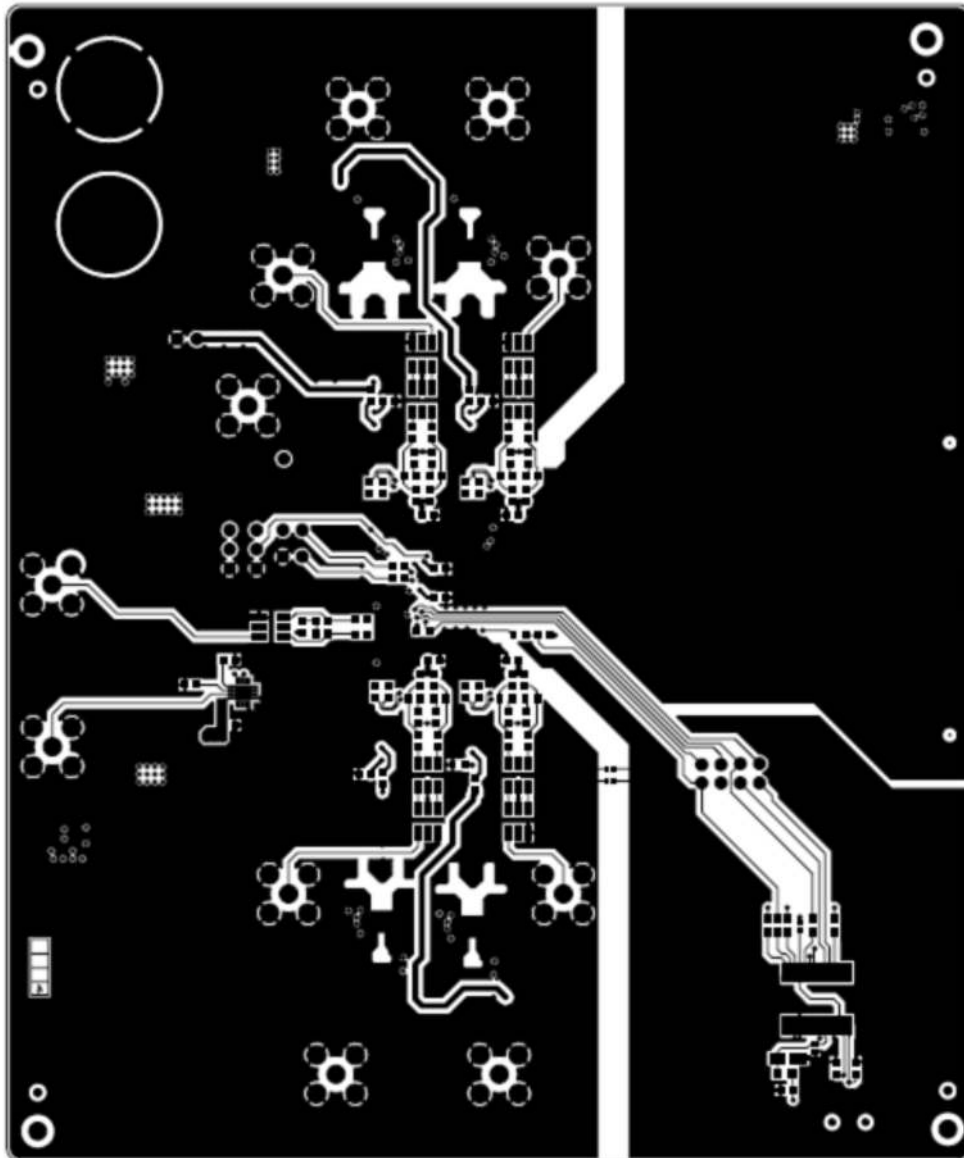

Figure 20. ADS5263EVM Bottom Layer Copper – Top View

7 Bill of Materials

Table 3. EVM Components List

Qty	Reference Designator	Value	Manufacturer	Part Number	Description
6	C1,C3,C5,C25,C29,C42	10 μ F	AVX	1206YC106MAT2A	CAP CER 10UF 16V X7R 20% 1206
4	C2,C4,C6,C40	1 μ F	AVX	0603YC105KAT2A	CAP CER 1.0UF 16V X7R 10% 0603
32	C10,C11,C12,C18,C19,C20, C21,C26,C27,C30,C43,C44, C45,C46,C59,C60,C61,C94, C99,C115,C116,C118,C119, C124,C125,C126,C152,C154 C28,C41,C95,C96	0.1 μ F	AVX	ECJ-1VB1C104K	CAP CER .10UF 50V X7R 10% 0603
8	C51,C52,C53,C54,C55,C56, C57,C58	220 pF	AVX	06035A221FAT2A	CAP CERM 220PF 1% 50V NP0 0603
1	C149	10 nF	Panasonic	ECJ-1VB1C103K	CAP 10000PF 16V CERM X7R 0603
2	C150,C153	47 pF	Panasonic	ECJ-1VC1H470J	CAP CERAMIC 47PF 50V 0603 SMD
1	C151	4.7 μ F	AVX	TAJA475K020R	
1	D2	MBRB2515L	MBRB2515LT4GOSCT-ND	MBRB2515LT4GOSCT-ND	DIODE SCHOTTKY 15V 25A D2PAK
2	JP2,JP3	HEADER 3POS 0.1 CTR	ANY	JUMPER,3P,,100CC	JUMPER,3P,,1CC
2	JP12,JP13	HEADER_1x2_100_430L	ANY		
1	J1	RED	ALLIED ELECTRONICS	ST-351A	Banana Female Red
1	J2	BLK	ALLIED ELECTRONICS	ST-351B	Banana Female Black
1	J8	QTH-060-02-F-D-A	SAMTEC	QTH-060-02-F-D-A	High speed connector
1	J13	USB_MINI_AB	JAE	DX3R005HN2E700	USB_MINI_AB
8	J14,J16,J17,J18,J19,J30,J31,J33	SMA	SAMTEC	SMA-J-P-H-ST-TH1	JACK PANEL MOUNT SMA
1	L7	1K at 100 MHz			
2	L18,L19	0 Ω	Panasonic	ERJ-3GEY0R00	RESISTOR,SMT,0603,0 OHM,5%, ZERO OHM JUMPER
8	L30,L31,L32,L33,L34,L35,L36,L37	56 nH	Panasonic	EXC-ML32A680U	Inductor
23	R3,R5,R7,R9,R10,R132, R133,R138,R139,R141,R165, R166,R169,R170,R171,R172, R175,R176,R188,R189,R190, R191,R192	0 Ω	Panasonic	ERJ-3GEY0R00	RESISTOR,SMT,0603,0 OHM,5%, ZERO OHM JUMPER
2	R4,R78	56.2K	Panasonic - ECG	ERJ-3EKF5622V	RES 56.2K OHM 1/10W 1% 0603 SMD
1	R6	50 Ω	Panasonic	ERJ-3EKF49R9V	RES 49.9 OHM 1/10W 1% 0603 SMD
8	R36,R37,R38,R39,R40,R41,R42,R43	25 Ω	Panasonic	ERJ-3EKF24R9V	RES 24.9 OHM 1/10W 1% 0603 SMD
2	R45,R48	100	Panasonic	ERJ-3EKF1000V	RES 100 OHM 1/10W 1% 0603 SMD
1	R46	10 Ω	Panasonic	ERJ-3EKF10R0V	RES 10.0 OHM 1/10W 1% 0603 SMD
2	R53,R56	10K	Panasonic	ERJ-3EKF1002V	RES 10.0K OHM 1/10W 1% 0603 SMD
8	R59,R60,R61,R62,R63,R64,R65,R67	12.4 Ω	Panasonic	ERJ-3EKF12R4V	RES 12.4 OHM 1/10W 1% 0603 SMD
2	R77,R152	56K	Panasonic	ERJ-3EKF5602V	RES 56.0K OHM 1/10W 1% 0603 SMD
2	R107,R108	250 Ω	Vishay	PLT0603Z2500AST5	RES 250 OHM 0.05% 5PPM 0603 SMD
2	R134,R135	200 Ω	Panasonic	ERJ-3EKF2000V	RES 200 OHM 1/10W 1% 0603 SMD
2	R136,R137	15 Ω	Vishay	CRCW06035R10FNEA	RES 15 OHM 1/10W 1% 0603 SMD
1	R142	50 Ω	Panasonic	ERJ-3EKF49R9V	RES 49.9 OHM 1/10W 1% 0603 SMD
2	R186,R187	0 Ω	Vishay/Dale	CRCW04023K00FKED	RESISTOR,SMT,0603,0 OHM,5%, ZERO OHM JUMPER
11	TP1,TP2,TP9,TP12,TP13, TP14,TP15,TP16,TP17,TP18,TP19	T POINT R			
1	T15	TC4-1W	MINI CIRCUITS	TC4-1WG2+	Transformer
8	T26,T27,T28,T29,T30,T31,T32,T33	WBC1-1	COIL CRAFT	WBC1-1TLB	Transformer
1	U1	ADS5263_QFN64	Texas Instruments		16-Bit Quad channel ADC
1	U6	FT245RL	FTDI	FT245RL	IC USB TO PARALLEL FIFO 28-SSOP
1	U10	TPS73201-SOT23	Texas Instruments	TPS73201DBVT	IC LDO REG 250MA ADJ-V SOT23-5
2	U11,U12	TPS77533D	Texas Instruments	TPS77533D	IC 3.3V 500MA LDO REG 8-SOIC
1	U19	THS770006	Texas Instruments	TPS770006IRGER	IC AMP DIFF ADC DVR 16BIT 24VQFN
1	U21	CDCLVP1102	Texas Instruments	CDCLVP1102RGTT	IC CLK BUFF 1:2 LVPECL SGL 16QFN
2	Z_SH-H3,Z_SH-H4	SHUNT-HEADER			
2	Z_SH-J1,Z_SH-J2	SHUNT-JUMPER-0402			

Table 3. EVM Components List (continued)

Qty	Reference Designator	Value	Manufacturer	Part Number	Description
4	STANDOFF HEX M3 THR ALUM 18MM		Digi-Key	24436K-ND	STANDOFF HEX M3 THR ALUM 18MM
4	SCREW STEEL M3 THR 6MM		Digi-Key	29311K-ND	SCREW STEEL M3 THR 6MM

High Speed Data Converter Pro (HSDCPro) GUI Installation

Download the HSDCPro GUI Installer using this link: [HSDCPro GUI](#)

- Unzip the saved folder and run the installer executable to obtain the pop-up shown in [Figure 21](#).
- Click the *Install* button.

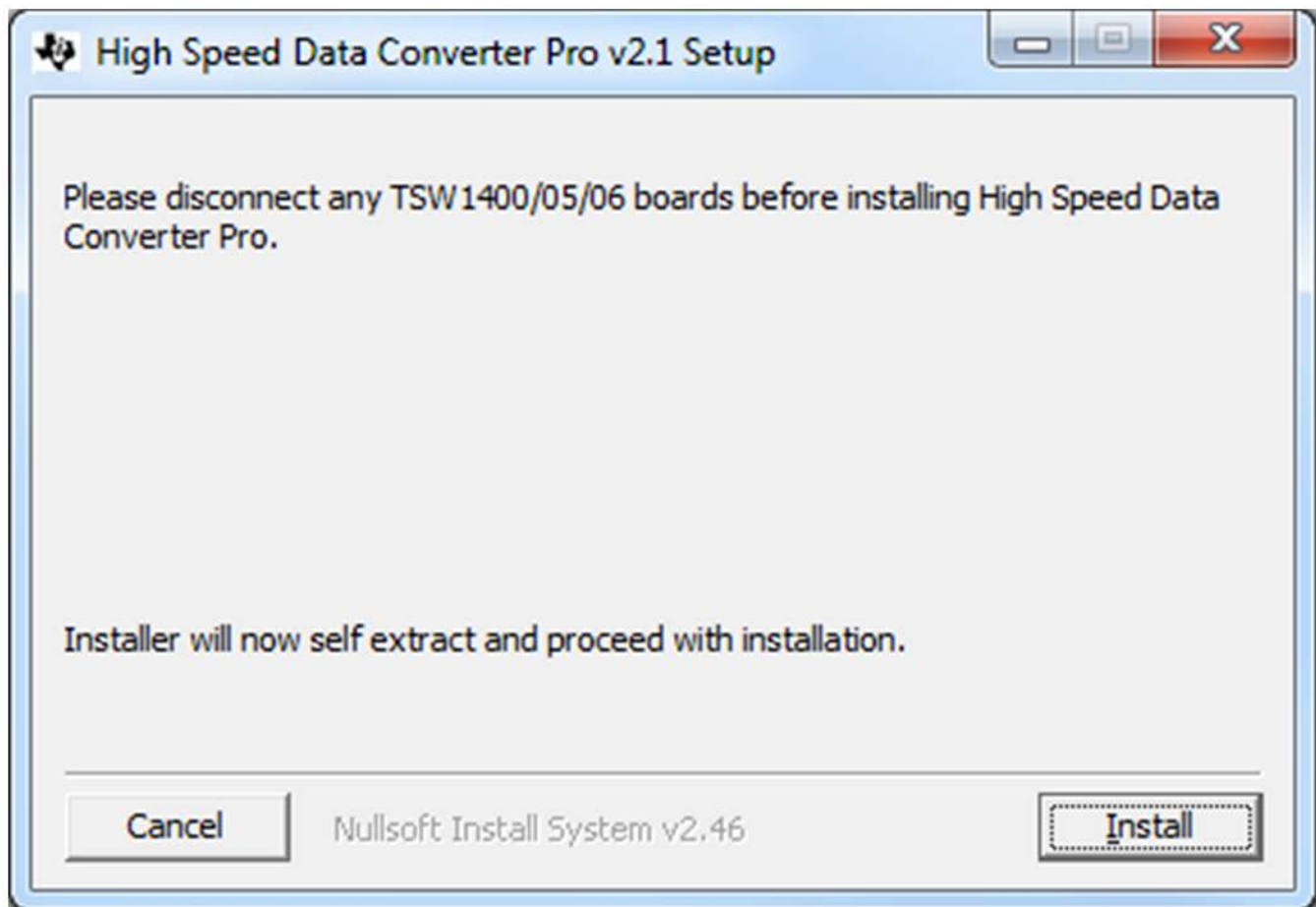

Figure 21. HSDCPro Install (Begin)

- Leave the destination directories as the default location, for the TSW1400GUI installation and press the NEXT button as shown in [Figure 22](#).

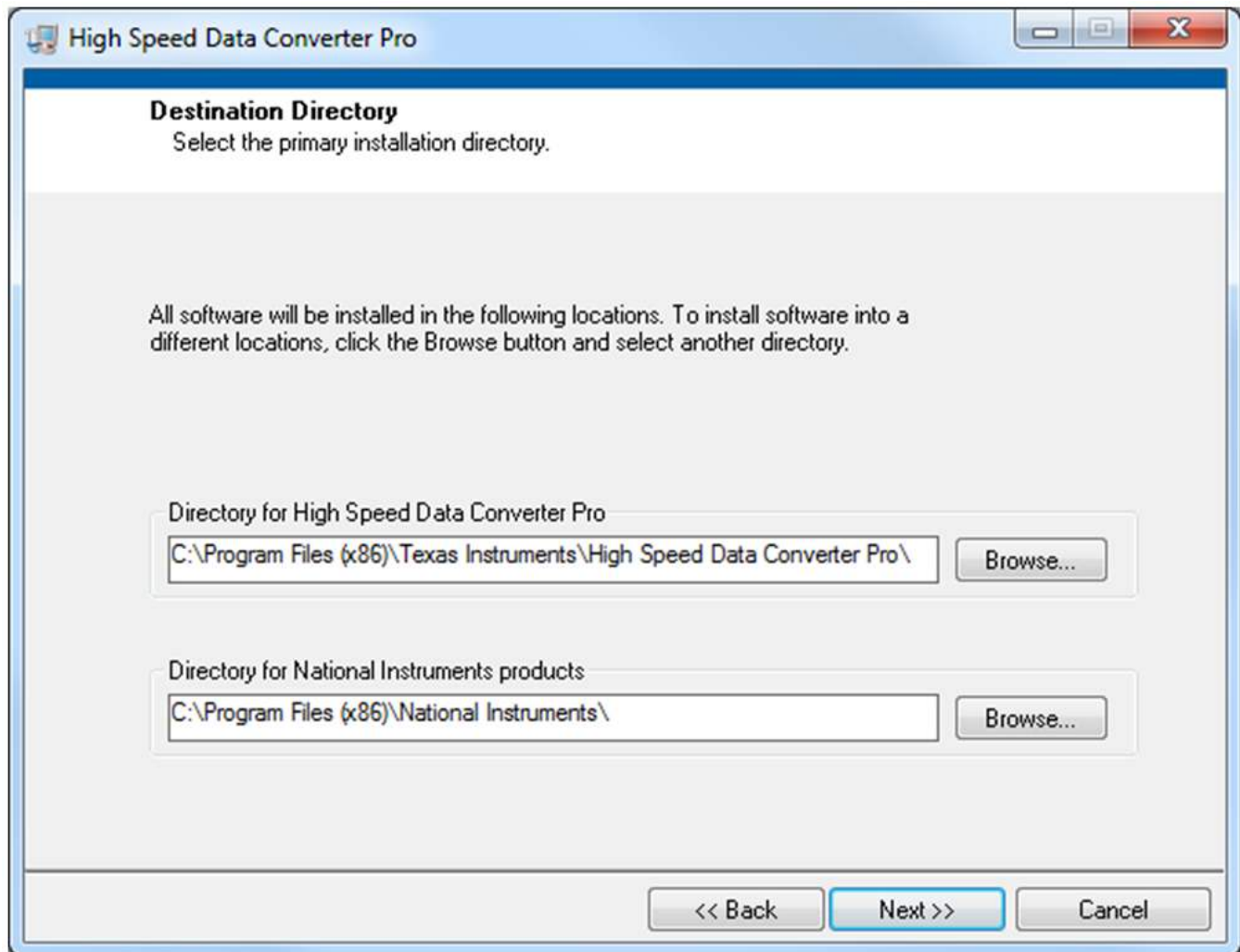

Figure 22. HSDCPro Install (Install Directory)

- Read the License Agreement from Texas Instruments and select *I accept the License Agreement* and press the *Next* button as shown in [Figure 23](#).

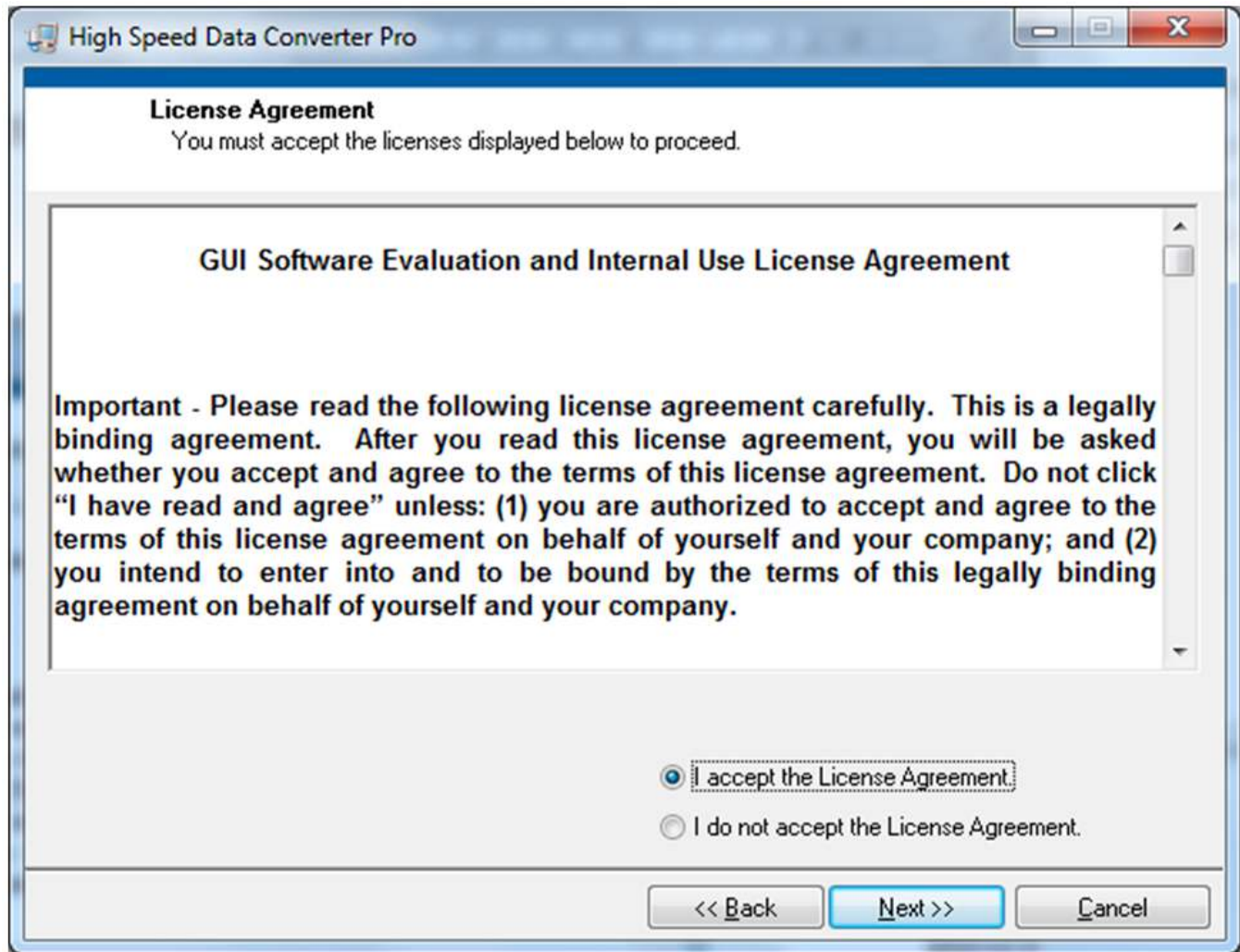

Figure 23. HSDCPro Install (TI License Agreement)

- Read the License Agreement from National Instruments and select *I accept the License Agreement* and press the *Next* button as shown in [Figure 24](#).

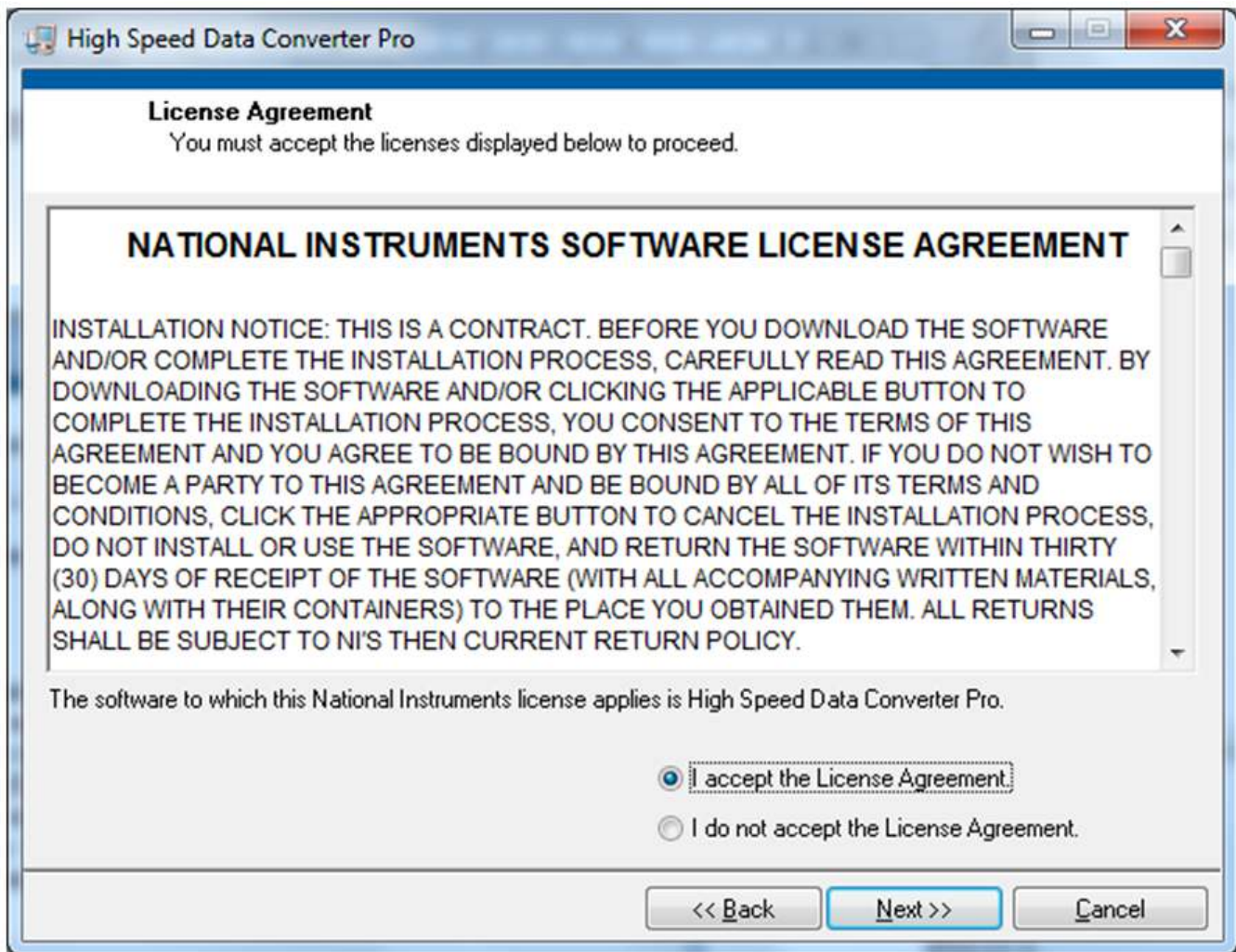

Figure 24. HSDCPro Install (NI License Agreement)

- Press the *Next* button as shown in [Figure 25](#).

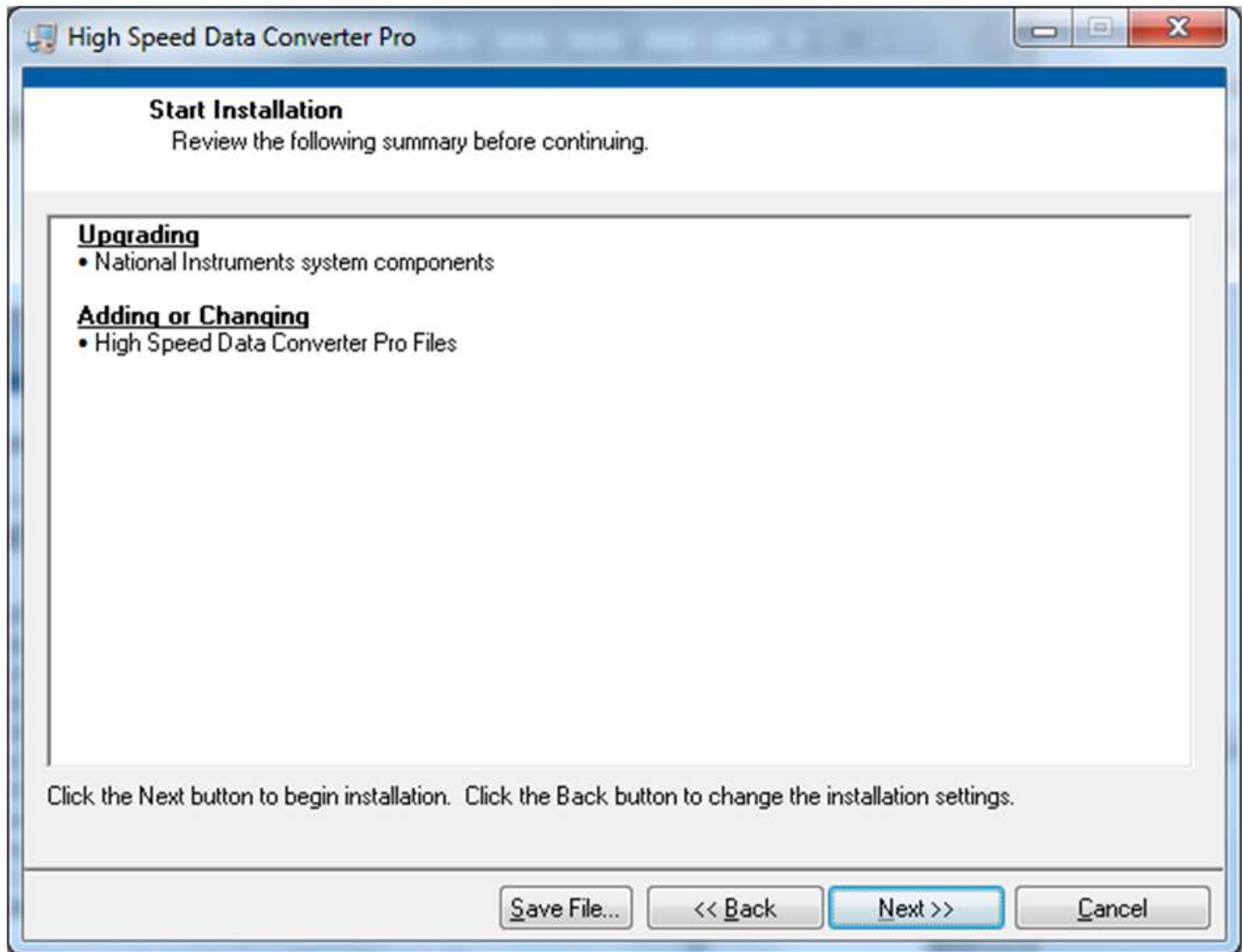

Figure 25. HSDCPro Install (Start Installation)

- The window shown in [Figure 26](#) should appear indicating that the installation is in progress.

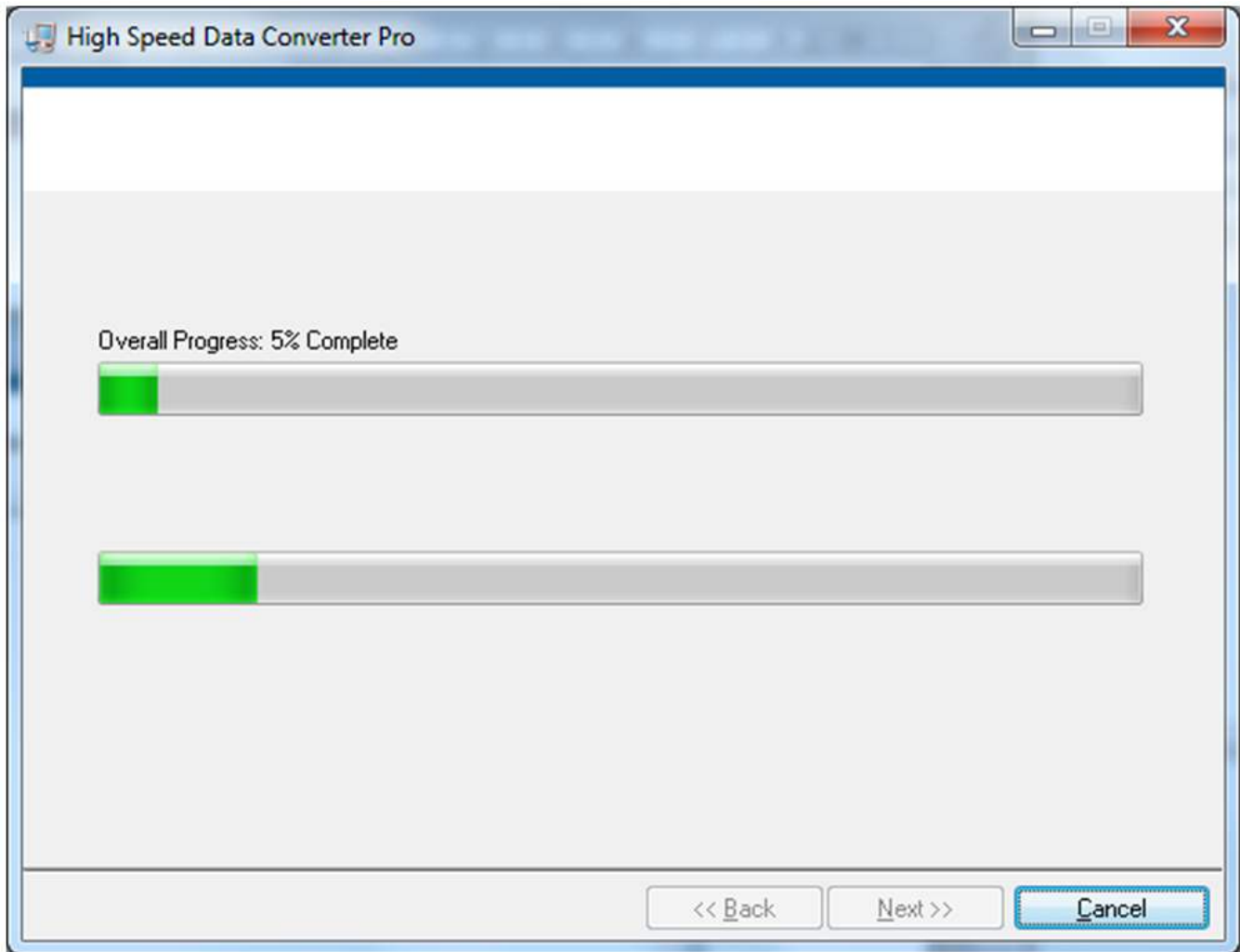

Figure 26. HSDCPro Install (Installation Progress)

- The window shown in [Figure 27](#) appears indicating *Installation Complete*. Press the *Next* button.

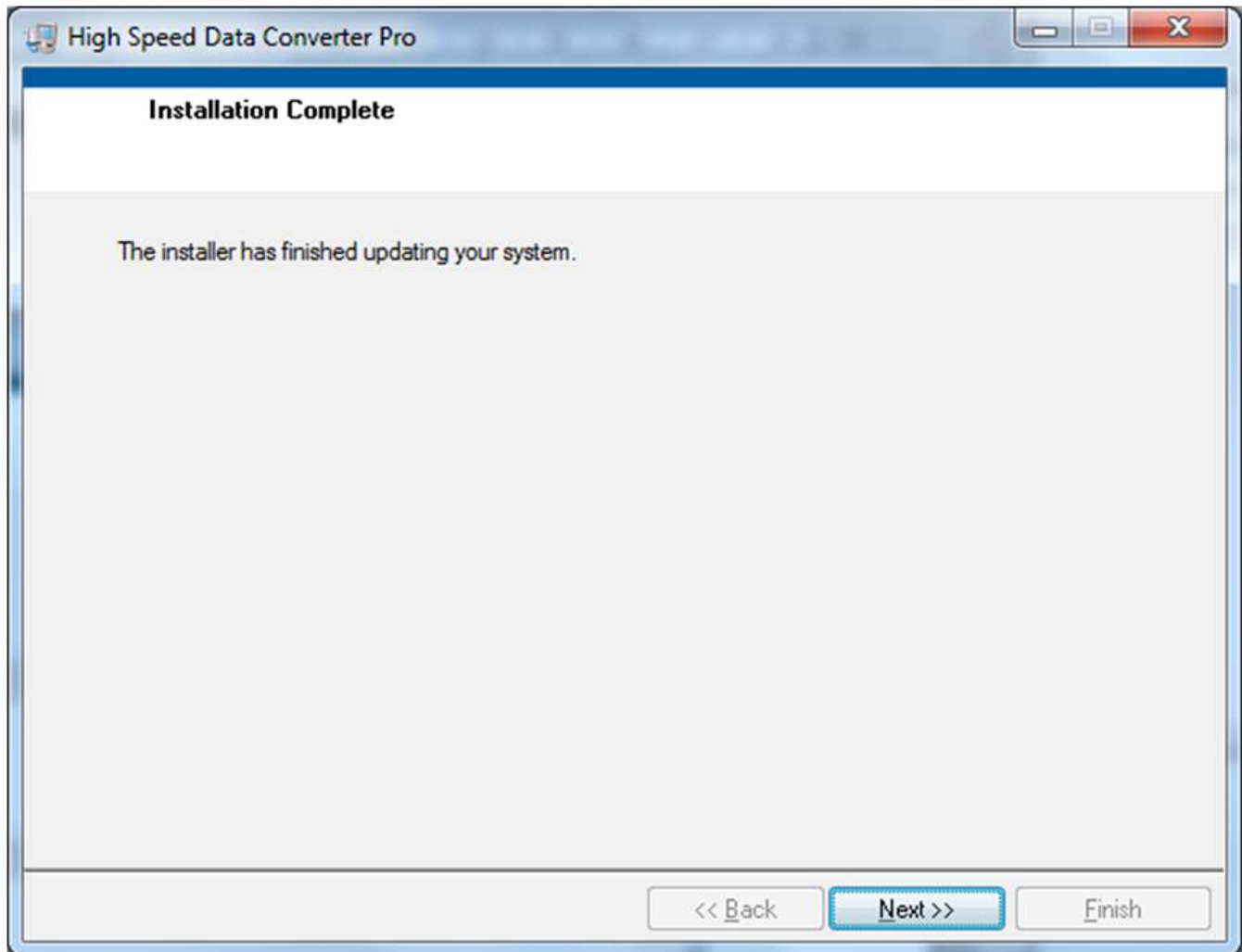

Figure 27. HSDCPro Install (Installation Complete)

- The window shown in [Figure 28](#) appears briefly to complete the process.

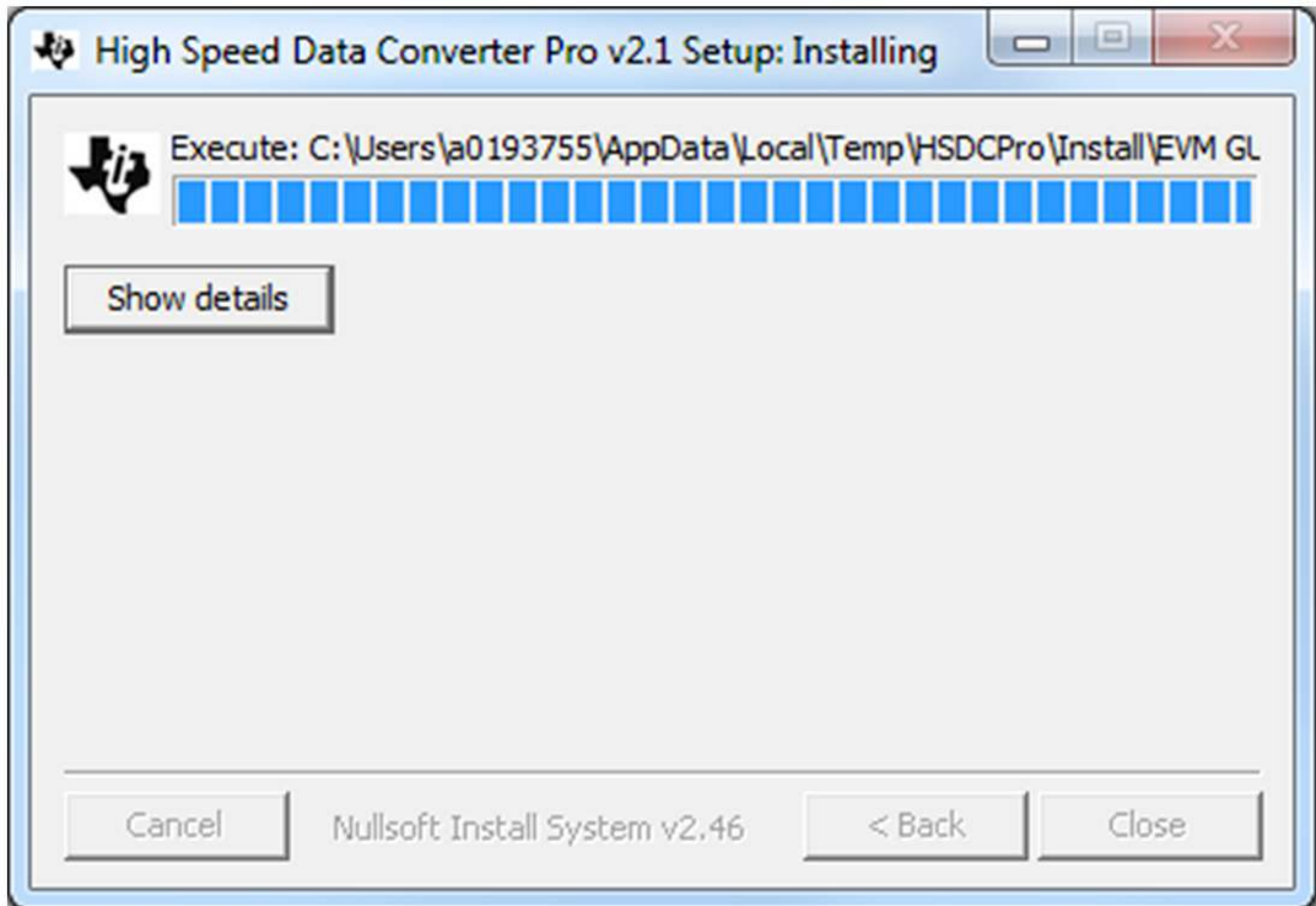

Figure 28. HSDCPro Install (h)

- As shown in Figure 29 a restart might be requested depending on whether or not the PC already had the National Instruments MCR Installer. If requested, hit the *Restart* button to complete the installation.

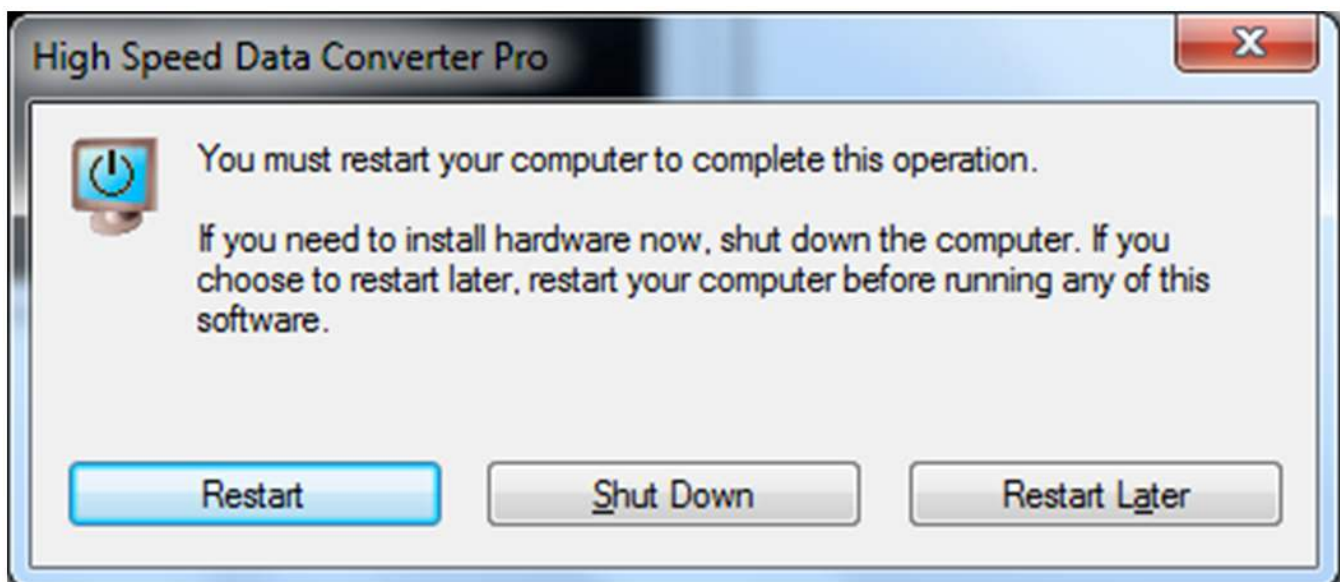

Figure 29. HSDCPro Install

EVM CONFIGURATION MODES

DEFAULT (SINGLE AMP) CONFIGURATION

Default Config (with transformer drive on 3 channels &
THS770006 on one channel (IN3A)

OPTIONAL (4 CHANNEL AMP) CONFIGURATION

THS7700 Config - THS770006-based drive on all 4 channels
Channel (IN1A, IN2A, IN3A IN4A)



TEXAS INSTRUMENTS

Title

ADS5263EVM

Size
A

EDGE No : 6526733
ECR No : 2115370

EVM CONFIGURATION

Rev
A

Date: Tuesday, May 03, 2011

Sheet 1 of 8

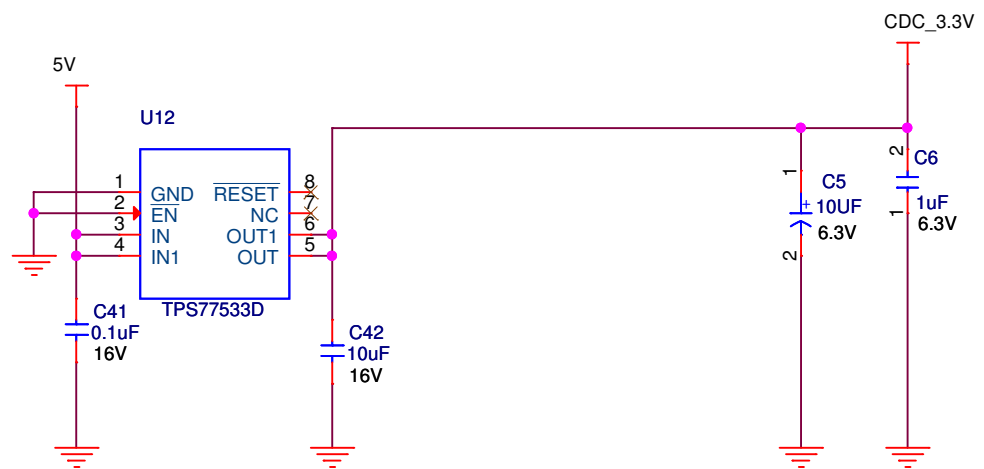
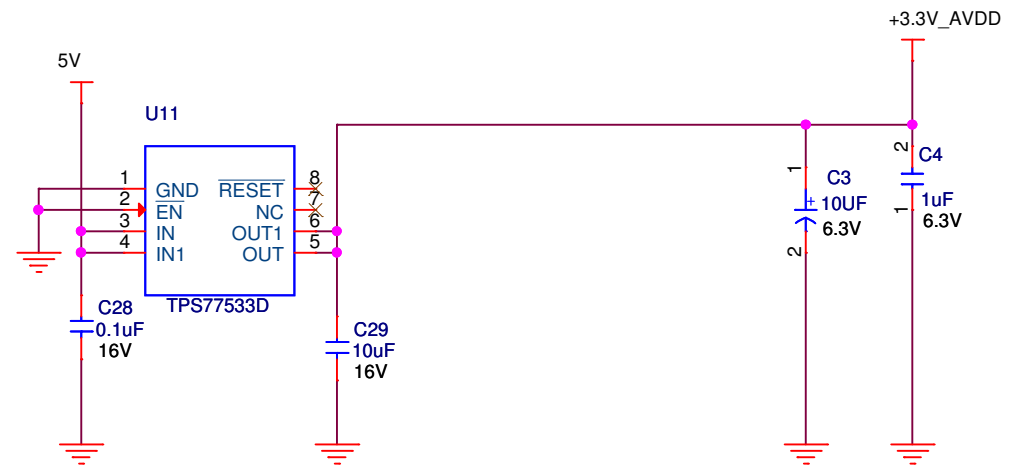
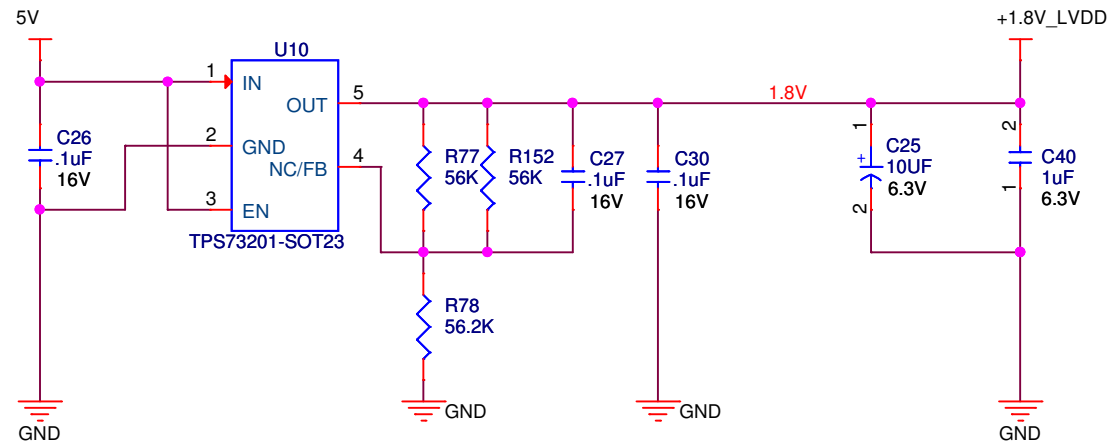
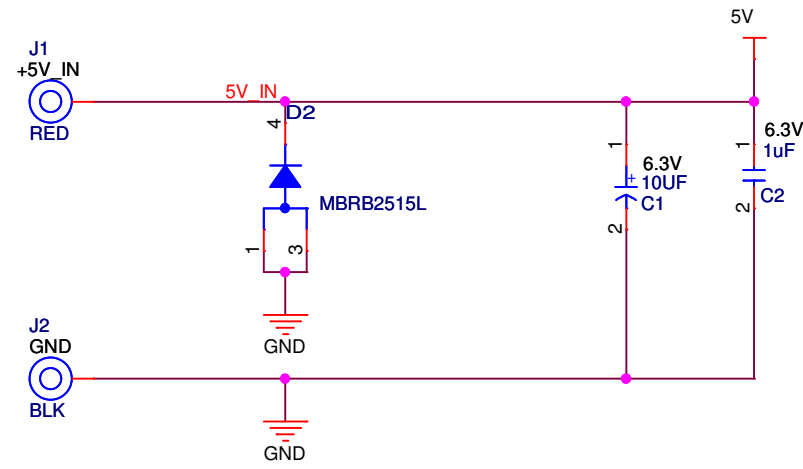

PLACE 0.1UF CLOSE TO DEVICE AVDD PINS

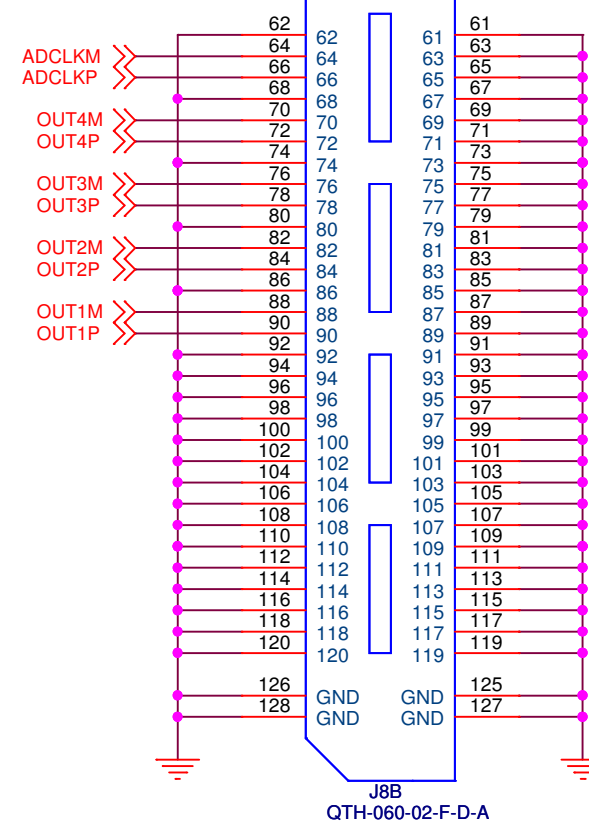
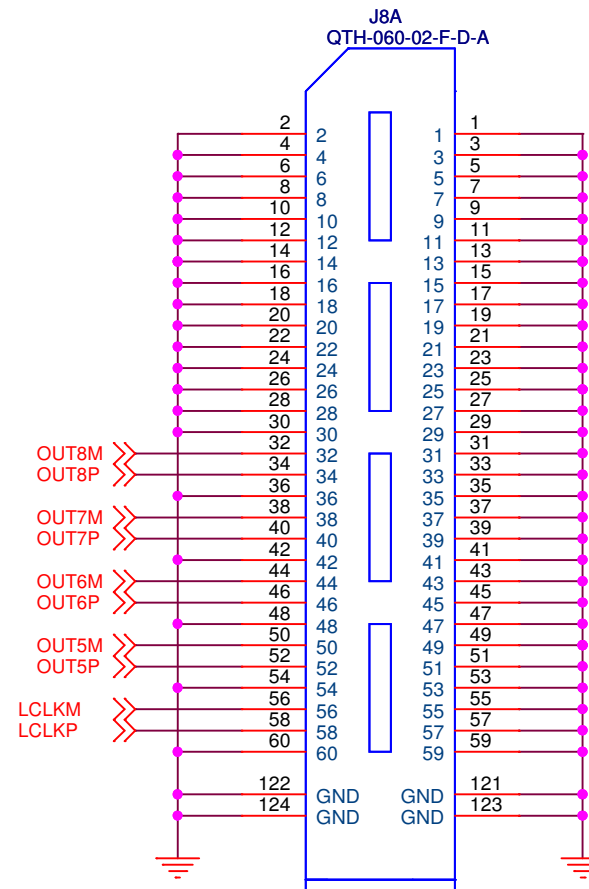
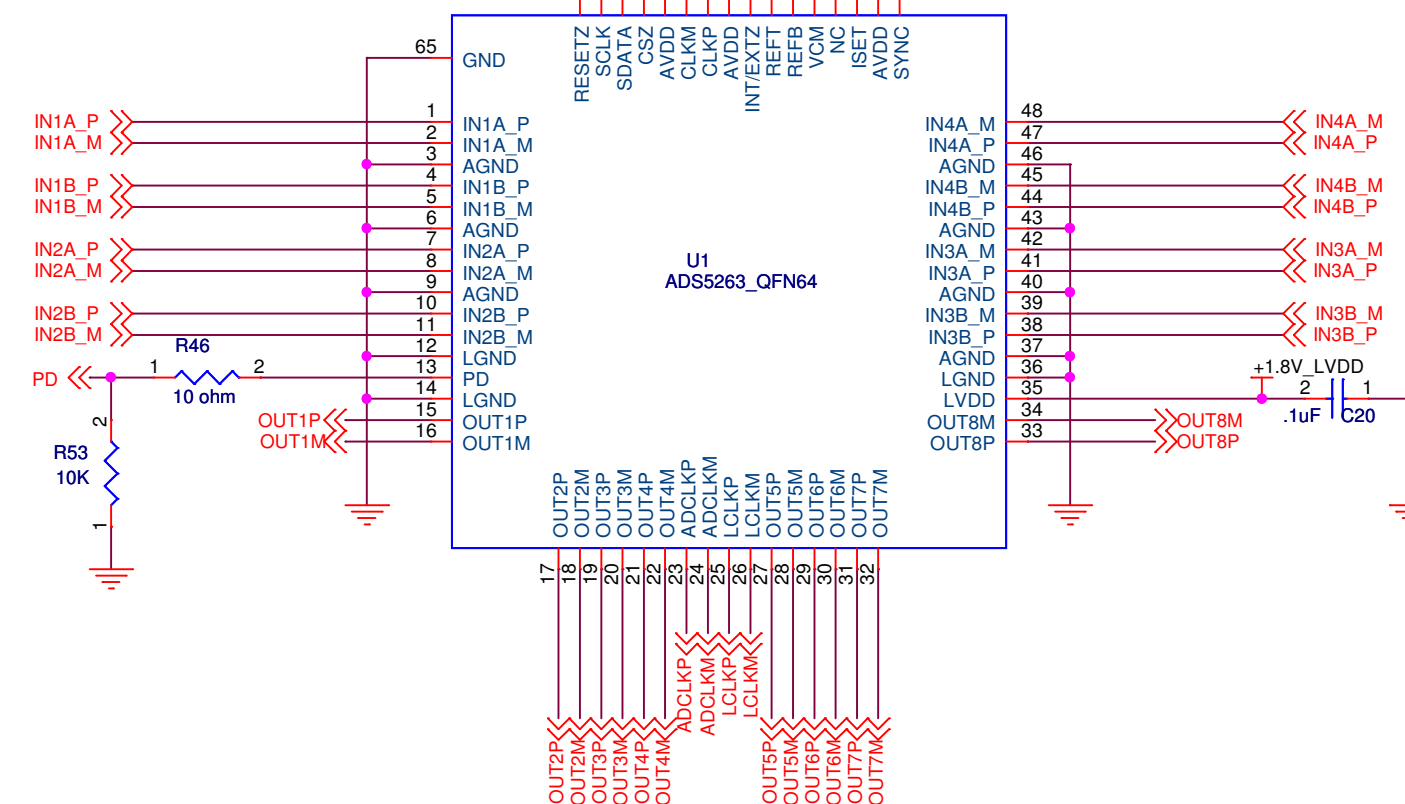
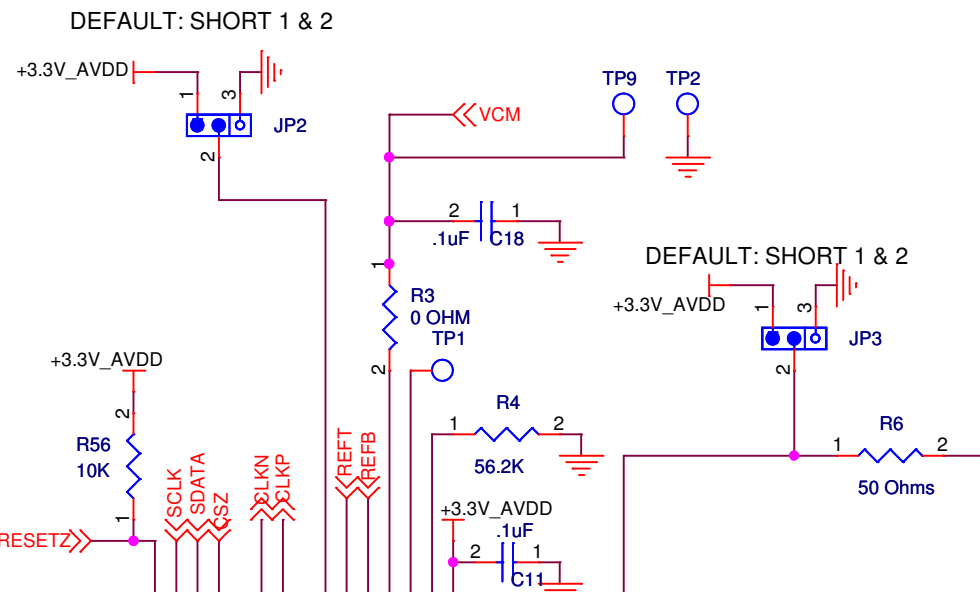
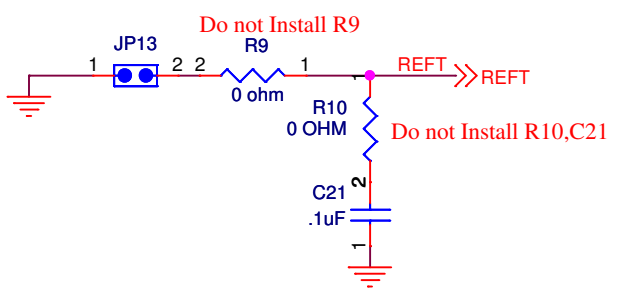
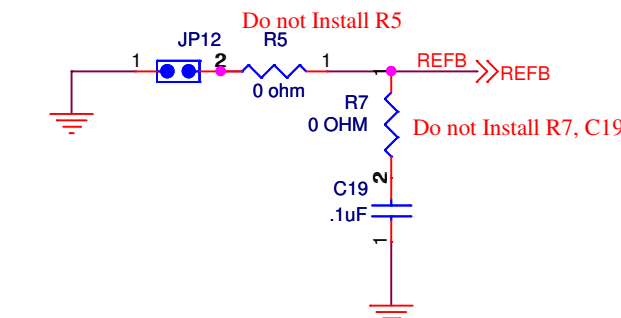
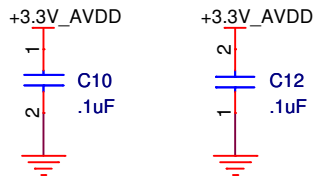

TEXAS INSTRUMENTS

Title: **ADS5263EVM**

Size: **B** | EDGE No: 6526733 | ECR No: 2115370 | **ADC** | Rev: **A**

Date: Tuesday, May 03, 2011 | Sheet 3 of 8

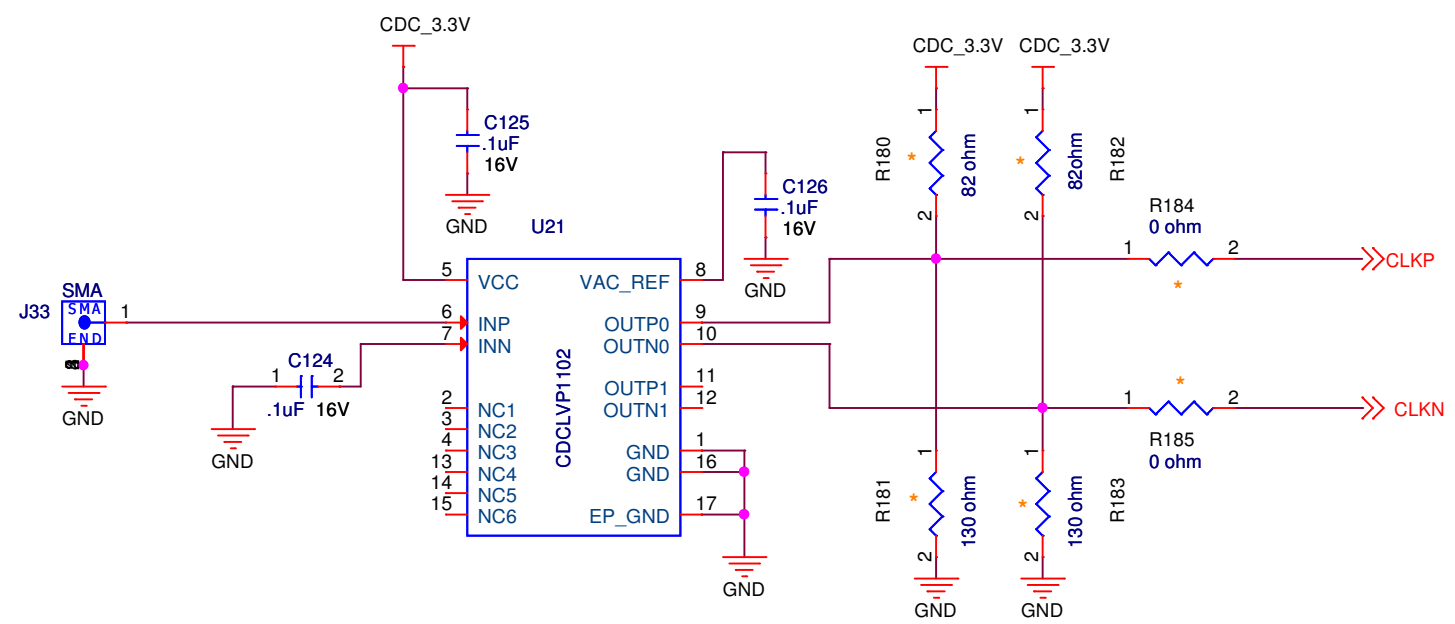
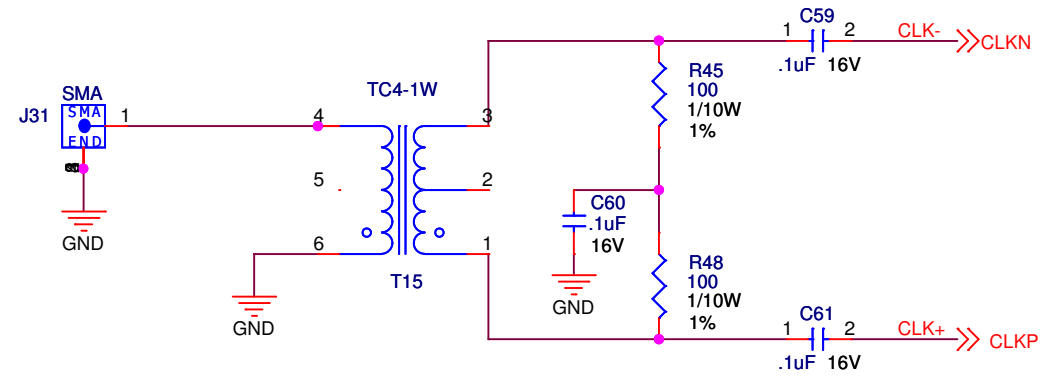

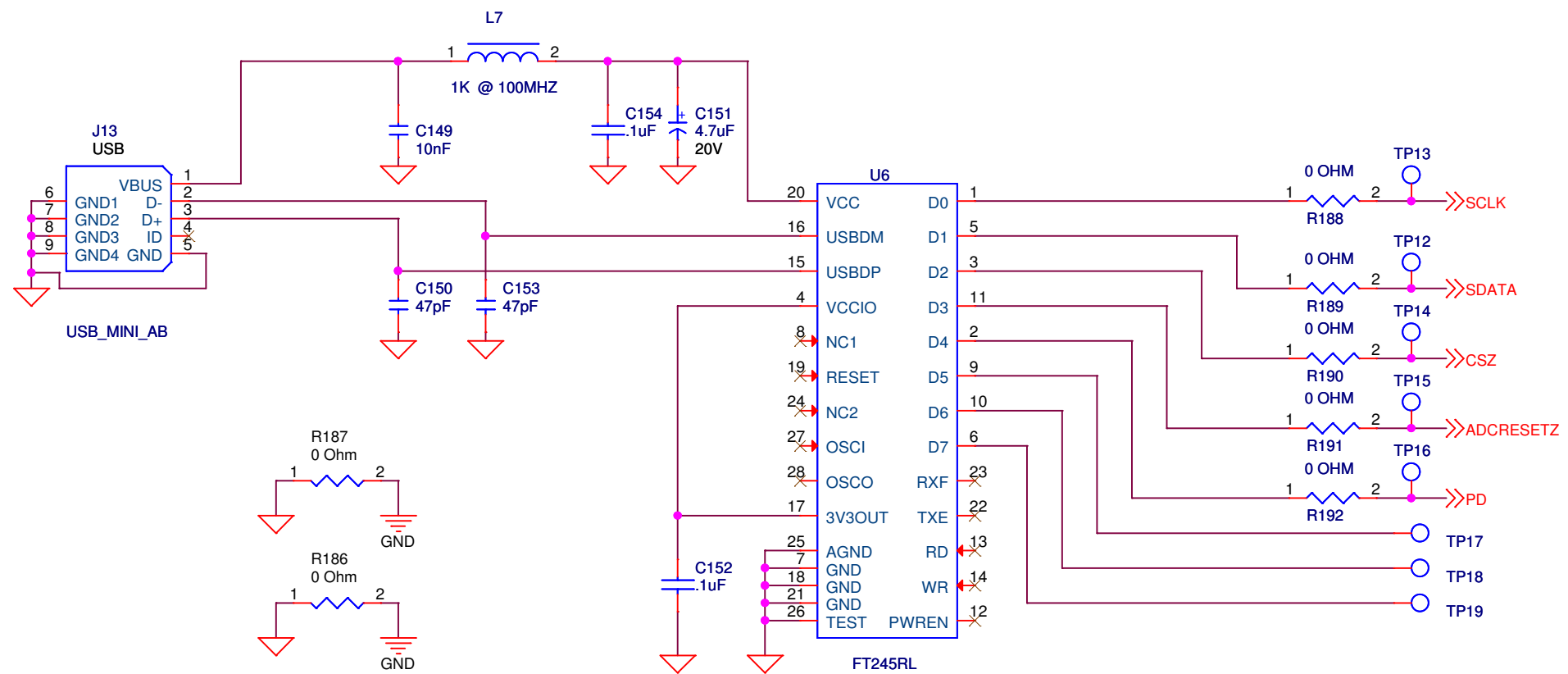

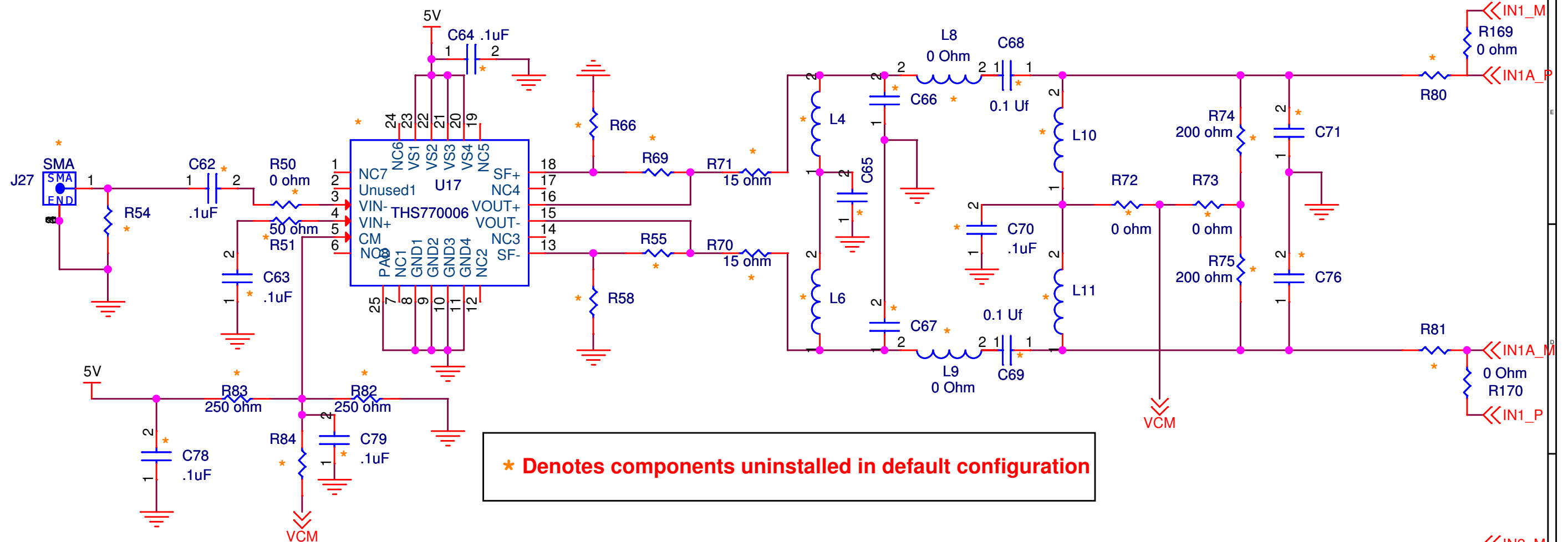

*** Denotes components uninstalled in default configuration**

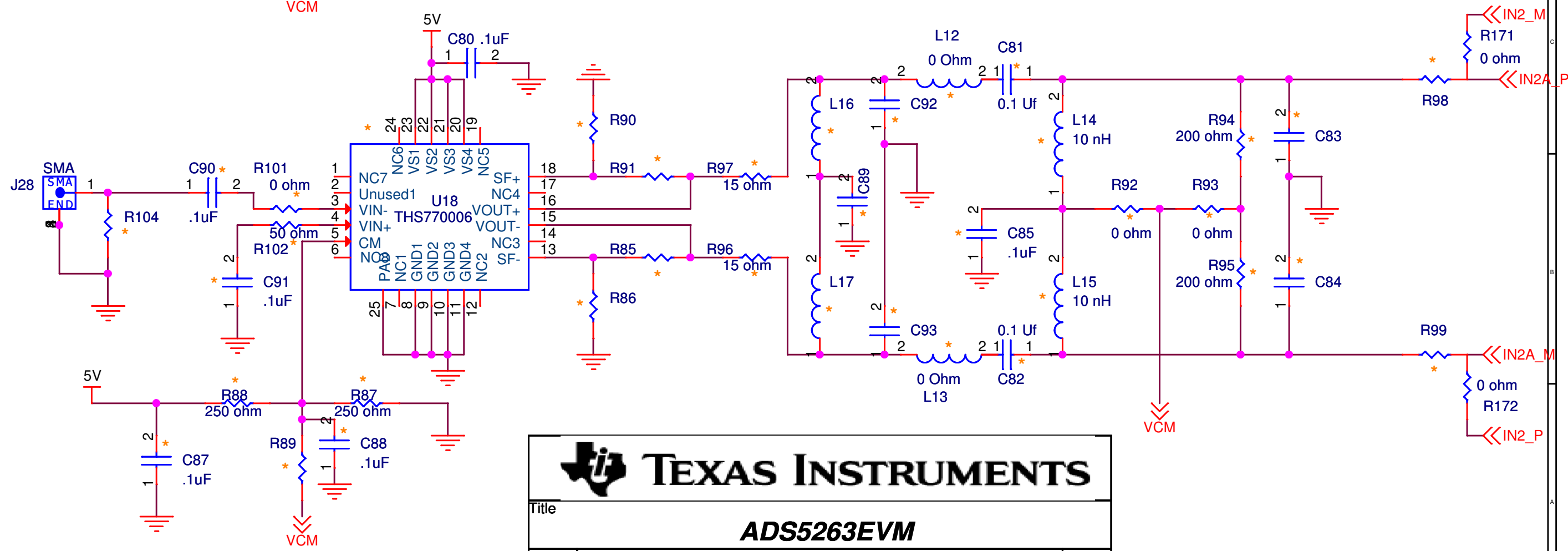

TEXAS INSTRUMENTS

Title: **ADS5263EVM**

Size: A	EDGE No : 6526733 ECR No : 2115370	Rev: A
----------------	---------------------------------------	---------------

Date: Tuesday, May 03, 2011 Sheet 6 of 8

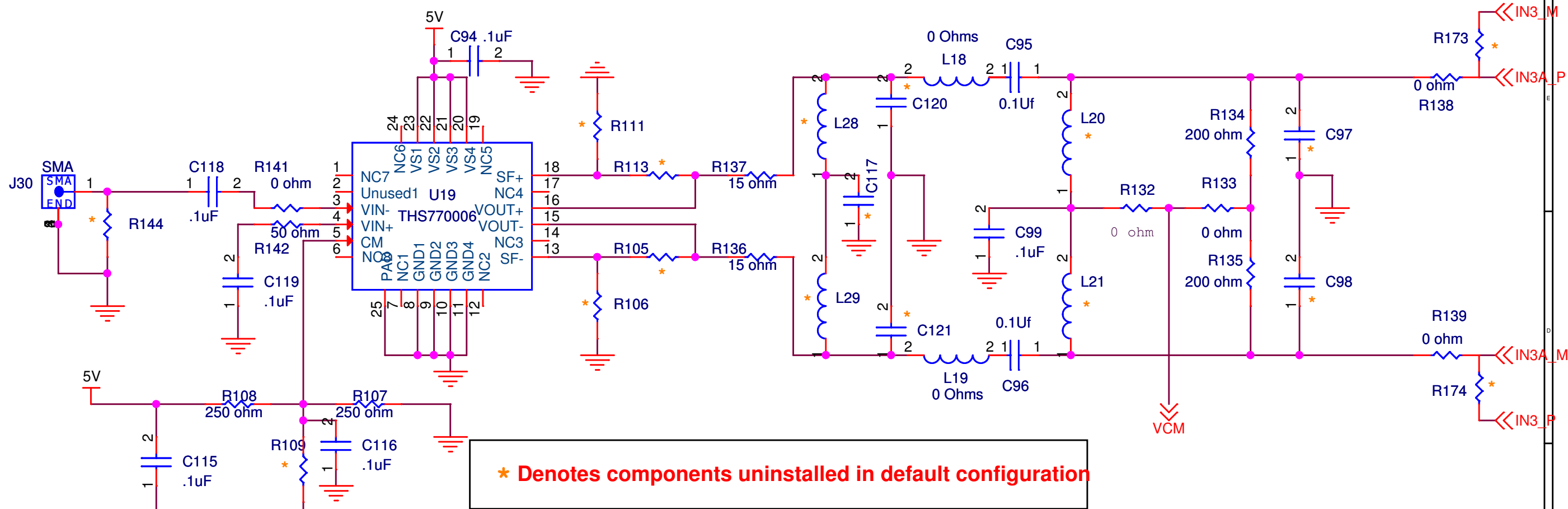

* Denotes components uninstalled in default configuration

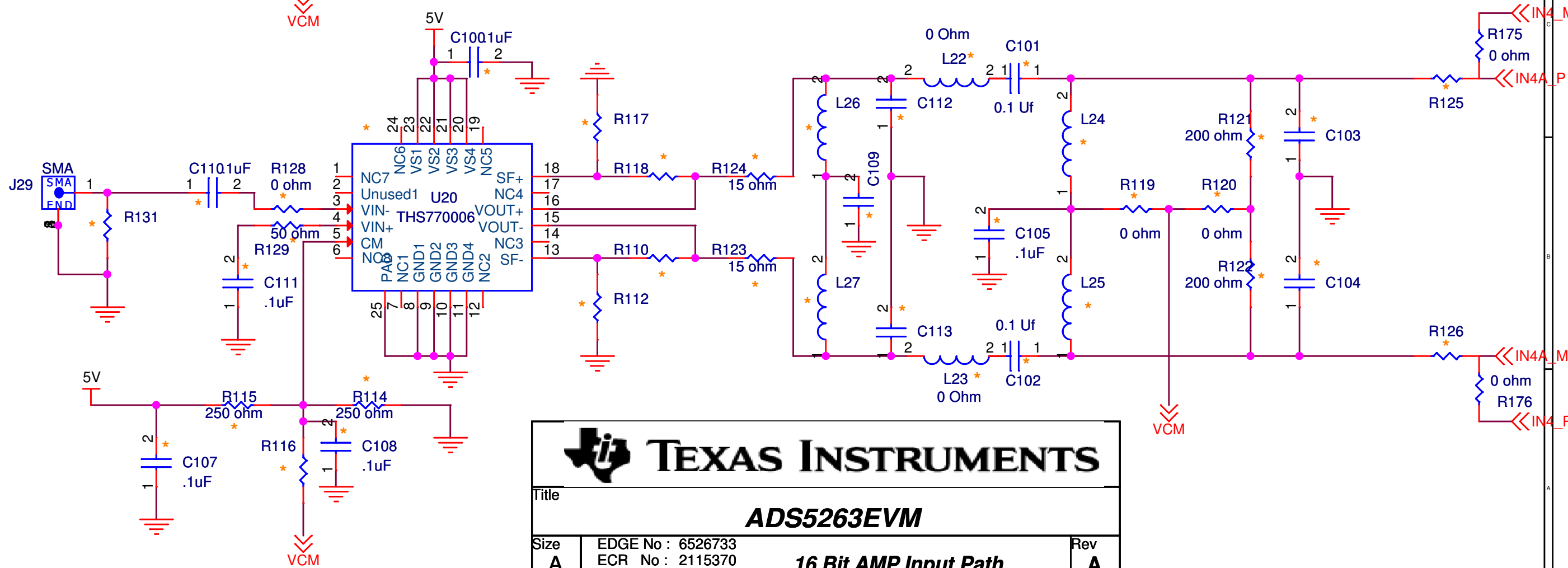

TEXAS INSTRUMENTS

Title: **ADS5263EVM**

Size	EDGE No : 6526733	Rev
A	ECR No : 2115370	A

Date: Tuesday, May 03, 2011 Sheet 7 of 8

* Denotes components not installed in default configuration

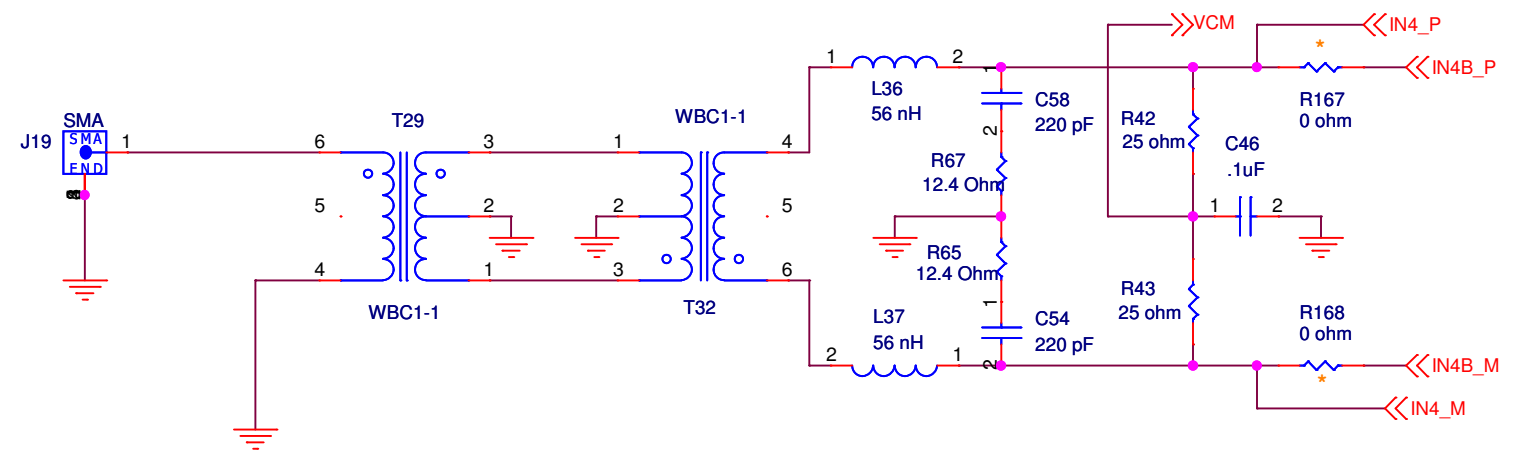
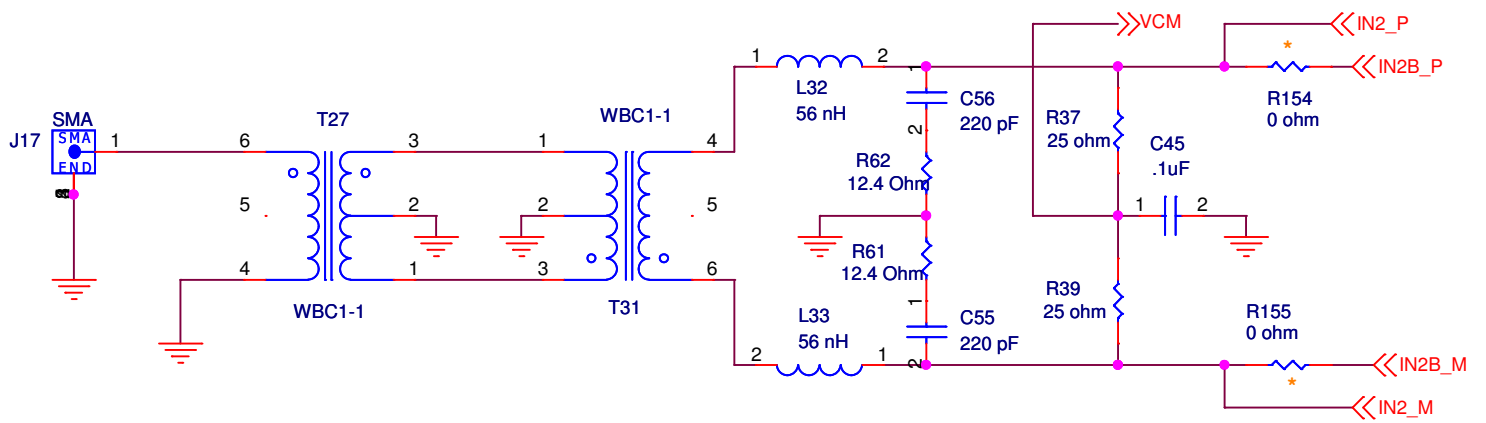
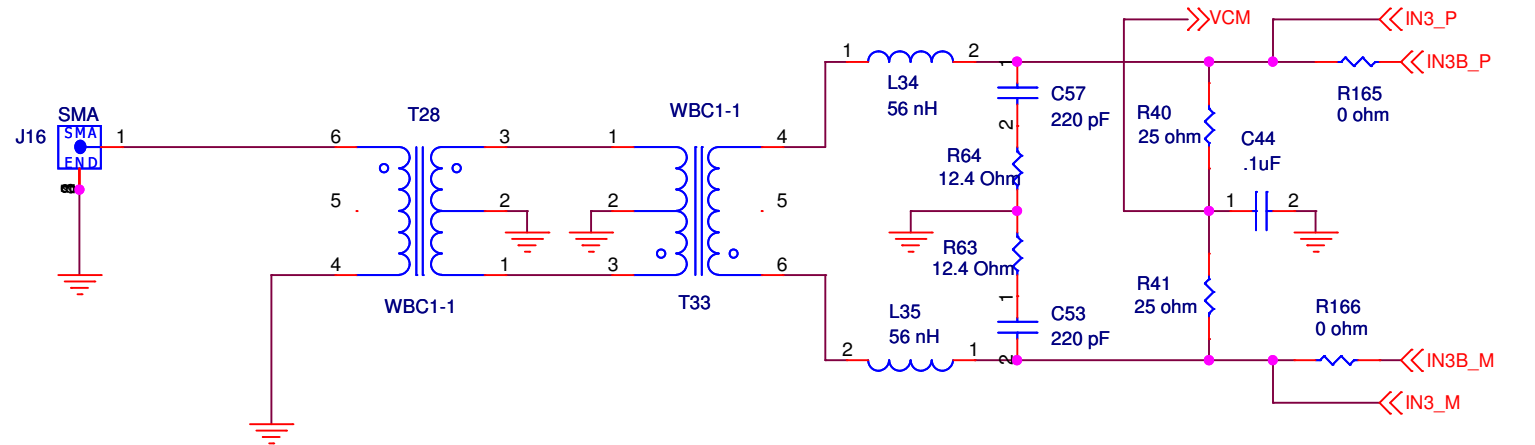
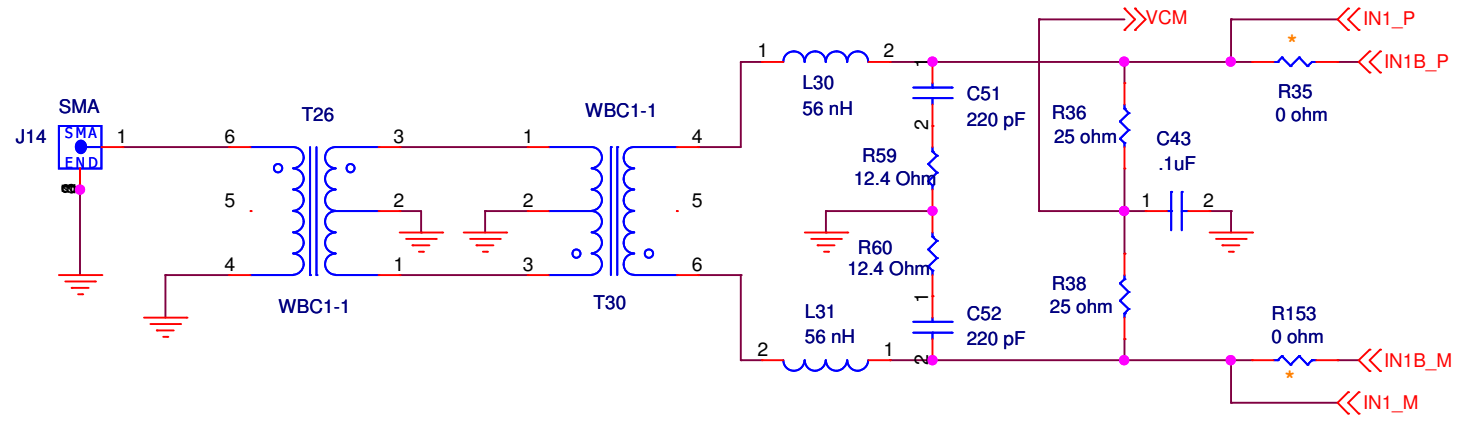

Revision History

Changes from Original (May 2011) to A Revision	Page
---	-------------

- Changed Appendix A to TSW1400 software. [25](#)
-

NOTE: Page numbers for previous revisions may differ from page numbers in the current version.

STANDARD TERMS AND CONDITIONS FOR EVALUATION MODULES

1. *Delivery:* TI delivers TI evaluation boards, kits, or modules, including any accompanying demonstration software, components, or documentation (collectively, an "EVM" or "EVMs") to the User ("User") in accordance with the terms and conditions set forth herein. Acceptance of the EVM is expressly subject to the following terms and conditions.
 - 1.1 EVMs are intended solely for product or software developers for use in a research and development setting to facilitate feasibility evaluation, experimentation, or scientific analysis of TI semiconductors products. EVMs have no direct function and are not finished products. EVMs shall not be directly or indirectly assembled as a part or subassembly in any finished product. For clarification, any software or software tools provided with the EVM ("Software") shall not be subject to the terms and conditions set forth herein but rather shall be subject to the applicable terms and conditions that accompany such Software
 - 1.2 EVMs are not intended for consumer or household use. EVMs may not be sold, sublicensed, leased, rented, loaned, assigned, or otherwise distributed for commercial purposes by Users, in whole or in part, or used in any finished product or production system.
2. *Limited Warranty and Related Remedies/Disclaimers:*
 - 2.1 These terms and conditions do not apply to Software. The warranty, if any, for Software is covered in the applicable Software License Agreement.
 - 2.2 TI warrants that the TI EVM will conform to TI's published specifications for ninety (90) days after the date TI delivers such EVM to User. Notwithstanding the foregoing, TI shall not be liable for any defects that are caused by neglect, misuse or mistreatment by an entity other than TI, including improper installation or testing, or for any EVMs that have been altered or modified in any way by an entity other than TI. Moreover, TI shall not be liable for any defects that result from User's design, specifications or instructions for such EVMs. Testing and other quality control techniques are used to the extent TI deems necessary or as mandated by government requirements. TI does not test all parameters of each EVM.
 - 2.3 If any EVM fails to conform to the warranty set forth above, TI's sole liability shall be at its option to repair or replace such EVM, or credit User's account for such EVM. TI's liability under this warranty shall be limited to EVMs that are returned during the warranty period to the address designated by TI and that are determined by TI not to conform to such warranty. If TI elects to repair or replace such EVM, TI shall have a reasonable time to repair such EVM or provide replacements. Repaired EVMs shall be warranted for the remainder of the original warranty period. Replaced EVMs shall be warranted for a new full ninety (90) day warranty period.
3. *Regulatory Notices:*
 - 3.1 *United States*
 - 3.1.1 *Notice applicable to EVMs not FCC-Approved:*

This kit is designed to allow product developers to evaluate electronic components, circuitry, or software associated with the kit to determine whether to incorporate such items in a finished product and software developers to write software applications for use with the end product. This kit is not a finished product and when assembled may not be resold or otherwise marketed unless all required FCC equipment authorizations are first obtained. Operation is subject to the condition that this product not cause harmful interference to licensed radio stations and that this product accept harmful interference. Unless the assembled kit is designed to operate under part 15, part 18 or part 95 of this chapter, the operator of the kit must operate under the authority of an FCC license holder or must secure an experimental authorization under part 5 of this chapter.
 - 3.1.2 *For EVMs annotated as FCC – FEDERAL COMMUNICATIONS COMMISSION Part 15 Compliant:*

CAUTION

This device complies with part 15 of the FCC Rules. Operation is subject to the following two conditions: (1) This device may not cause harmful interference, and (2) this device must accept any interference received, including interference that may cause undesired operation.

Changes or modifications not expressly approved by the party responsible for compliance could void the user's authority to operate the equipment.

FCC Interference Statement for Class A EVM devices

NOTE: This equipment has been tested and found to comply with the limits for a Class A digital device, pursuant to part 15 of the FCC Rules. These limits are designed to provide reasonable protection against harmful interference when the equipment is operated in a commercial environment. This equipment generates, uses, and can radiate radio frequency energy and, if not installed and used in accordance with the instruction manual, may cause harmful interference to radio communications. Operation of this equipment in a residential area is likely to cause harmful interference in which case the user will be required to correct the interference at his own expense.

FCC Interference Statement for Class B EVM devices

NOTE: This equipment has been tested and found to comply with the limits for a Class B digital device, pursuant to part 15 of the FCC Rules. These limits are designed to provide reasonable protection against harmful interference in a residential installation. This equipment generates, uses and can radiate radio frequency energy and, if not installed and used in accordance with the instructions, may cause harmful interference to radio communications. However, there is no guarantee that interference will not occur in a particular installation. If this equipment does cause harmful interference to radio or television reception, which can be determined by turning the equipment off and on, the user is encouraged to try to correct the interference by one or more of the following measures:

- Reorient or relocate the receiving antenna.
- Increase the separation between the equipment and receiver.
- Connect the equipment into an outlet on a circuit different from that to which the receiver is connected.
- Consult the dealer or an experienced radio/TV technician for help.

3.2 Canada

3.2.1 For EVMs issued with an Industry Canada Certificate of Conformance to RSS-210

Concerning EVMs Including Radio Transmitters:

This device complies with Industry Canada license-exempt RSS standard(s). Operation is subject to the following two conditions: (1) this device may not cause interference, and (2) this device must accept any interference, including interference that may cause undesired operation of the device.

Concernant les EVMs avec appareils radio:

Le présent appareil est conforme aux CNR d'Industrie Canada applicables aux appareils radio exempts de licence. L'exploitation est autorisée aux deux conditions suivantes: (1) l'appareil ne doit pas produire de brouillage, et (2) l'utilisateur de l'appareil doit accepter tout brouillage radioélectrique subi, même si le brouillage est susceptible d'en compromettre le fonctionnement.

Concerning EVMs Including Detachable Antennas:

Under Industry Canada regulations, this radio transmitter may only operate using an antenna of a type and maximum (or lesser) gain approved for the transmitter by Industry Canada. To reduce potential radio interference to other users, the antenna type and its gain should be so chosen that the equivalent isotropically radiated power (e.i.r.p.) is not more than that necessary for successful communication. This radio transmitter has been approved by Industry Canada to operate with the antenna types listed in the user guide with the maximum permissible gain and required antenna impedance for each antenna type indicated. Antenna types not included in this list, having a gain greater than the maximum gain indicated for that type, are strictly prohibited for use with this device.

Concernant les EVMs avec antennes détachables

Conformément à la réglementation d'Industrie Canada, le présent émetteur radio peut fonctionner avec une antenne d'un type et d'un gain maximal (ou inférieur) approuvé pour l'émetteur par Industrie Canada. Dans le but de réduire les risques de brouillage radioélectrique à l'intention des autres utilisateurs, il faut choisir le type d'antenne et son gain de sorte que la puissance isotrope rayonnée équivalente (p.i.r.e.) ne dépasse pas l'intensité nécessaire à l'établissement d'une communication satisfaisante. Le présent émetteur radio a été approuvé par Industrie Canada pour fonctionner avec les types d'antenne énumérés dans le manuel d'usage et ayant un gain admissible maximal et l'impédance requise pour chaque type d'antenne. Les types d'antenne non inclus dans cette liste, ou dont le gain est supérieur au gain maximal indiqué, sont strictement interdits pour l'exploitation de l'émetteur.

3.3 Japan

3.3.1 *Notice for EVMs delivered in Japan:* Please see http://www.tij.co.jp/llds/ti_ja/general/eStore/notice_01.page 日本国内に輸入される評価用キット、ボードについては、次のところをご覧ください。
http://www.tij.co.jp/llds/ti_ja/general/eStore/notice_01.page

3.3.2 *Notice for Users of EVMs Considered "Radio Frequency Products" in Japan:* EVMs entering Japan are NOT certified by TI as conforming to Technical Regulations of Radio Law of Japan.

If User uses EVMs in Japan, User is required by Radio Law of Japan to follow the instructions below with respect to EVMs:

1. Use EVMs in a shielded room or any other test facility as defined in the notification #173 issued by Ministry of Internal Affairs and Communications on March 28, 2006, based on Sub-section 1.1 of Article 6 of the Ministry's Rule for Enforcement of Radio Law of Japan,
2. Use EVMs only after User obtains the license of Test Radio Station as provided in Radio Law of Japan with respect to EVMs, or
3. Use of EVMs only after User obtains the Technical Regulations Conformity Certification as provided in Radio Law of Japan with respect to EVMs. Also, do not transfer EVMs, unless User gives the same notice above to the transferee. Please note that if User does not follow the instructions above, User will be subject to penalties of Radio Law of Japan.

【無線電波を送信する製品の開発キットをお使いになる際の注意事項】

本開発キットは技術基準適合証明を受けておりません。

本製品のご使用に際しては、電波法遵守のため、以下のいずれかの措置を取っていただく必要がありますのでご注意ください。

1. 電波法施行規則第6条第1項第1号に基づく平成18年3月28日総務省告示第173号で定められた電波暗室等の試験設備でご使用いただく。
2. 実験局の免許を取得後ご使用いただく。
3. 技術基準適合証明を取得後ご使用いただく。

なお、本製品は、上記の「ご使用にあたっての注意」を譲渡先、移転先に通知しない限り、譲渡、移転できないものとします。

上記を遵守頂けない場合は、電波法の罰則が適用される可能性があることをご留意ください。

日本テキサス・インスツルメンツ株式会社

東京都新宿区西新宿 6 丁目 2 4 番 1 号

西新宿三井ビル

3.3.3 *Notice for EVMs for Power Line Communication:* Please see http://www.tij.co.jp/llds/ti_ja/general/eStore/notice_02.page

電力線搬送波通信についての開発キットをお使いになる際の注意事項については、次のところをご覧ください。http://www.tij.co.jp/llds/ti_ja/general/eStore/notice_02.page

4 *EVM Use Restrictions and Warnings:*

4.1 EVMS ARE NOT FOR USE IN FUNCTIONAL SAFETY AND/OR SAFETY CRITICAL EVALUATIONS, INCLUDING BUT NOT LIMITED TO EVALUATIONS OF LIFE SUPPORT APPLICATIONS.

4.2 User must read and apply the user guide and other available documentation provided by TI regarding the EVM prior to handling or using the EVM, including without limitation any warning or restriction notices. The notices contain important safety information related to, for example, temperatures and voltages.

4.3 *Safety-Related Warnings and Restrictions:*

4.3.1 User shall operate the EVM within TI's recommended specifications and environmental considerations stated in the user guide, other available documentation provided by TI, and any other applicable requirements and employ reasonable and customary safeguards. Exceeding the specified performance ratings and specifications (including but not limited to input and output voltage, current, power, and environmental ranges) for the EVM may cause personal injury or death, or property damage. If there are questions concerning performance ratings and specifications, User should contact a TI field representative prior to connecting interface electronics including input power and intended loads. Any loads applied outside of the specified output range may also result in unintended and/or inaccurate operation and/or possible permanent damage to the EVM and/or interface electronics. Please consult the EVM user guide prior to connecting any load to the EVM output. If there is uncertainty as to the load specification, please contact a TI field representative. During normal operation, even with the inputs and outputs kept within the specified allowable ranges, some circuit components may have elevated case temperatures. These components include but are not limited to linear regulators, switching transistors, pass transistors, current sense resistors, and heat sinks, which can be identified using the information in the associated documentation. When working with the EVM, please be aware that the EVM may become very warm.

4.3.2 EVMs are intended solely for use by technically qualified, professional electronics experts who are familiar with the dangers and application risks associated with handling electrical mechanical components, systems, and subsystems. User assumes all responsibility and liability for proper and safe handling and use of the EVM by User or its employees, affiliates, contractors or designees. User assumes all responsibility and liability to ensure that any interfaces (electronic and/or mechanical) between the EVM and any human body are designed with suitable isolation and means to safely limit accessible leakage currents to minimize the risk of electrical shock hazard. User assumes all responsibility and liability for any improper or unsafe handling or use of the EVM by User or its employees, affiliates, contractors or designees.

4.4 User assumes all responsibility and liability to determine whether the EVM is subject to any applicable international, federal, state, or local laws and regulations related to User's handling and use of the EVM and, if applicable, User assumes all responsibility and liability for compliance in all respects with such laws and regulations. User assumes all responsibility and liability for proper disposal and recycling of the EVM consistent with all applicable international, federal, state, and local requirements.

5. *Accuracy of Information:* To the extent TI provides information on the availability and function of EVMs, TI attempts to be as accurate as possible. However, TI does not warrant the accuracy of EVM descriptions, EVM availability or other information on its websites as accurate, complete, reliable, current, or error-free.

6. *Disclaimers:*
- 6.1 EXCEPT AS SET FORTH ABOVE, EVMS AND ANY WRITTEN DESIGN MATERIALS PROVIDED WITH THE EVM (AND THE DESIGN OF THE EVM ITSELF) ARE PROVIDED "AS IS" AND "WITH ALL FAULTS." TI DISCLAIMS ALL OTHER WARRANTIES, EXPRESS OR IMPLIED, REGARDING SUCH ITEMS, INCLUDING BUT NOT LIMITED TO ANY IMPLIED WARRANTIES OF MERCHANTABILITY OR FITNESS FOR A PARTICULAR PURPOSE OR NON-INFRINGEMENT OF ANY THIRD PARTY PATENTS, COPYRIGHTS, TRADE SECRETS OR OTHER INTELLECTUAL PROPERTY RIGHTS.
- 6.2 EXCEPT FOR THE LIMITED RIGHT TO USE THE EVM SET FORTH HEREIN, NOTHING IN THESE TERMS AND CONDITIONS SHALL BE CONSTRUED AS GRANTING OR CONFERRING ANY RIGHTS BY LICENSE, PATENT, OR ANY OTHER INDUSTRIAL OR INTELLECTUAL PROPERTY RIGHT OF TI, ITS SUPPLIERS/LICENSORS OR ANY OTHER THIRD PARTY, TO USE THE EVM IN ANY FINISHED END-USER OR READY-TO-USE FINAL PRODUCT, OR FOR ANY INVENTION, DISCOVERY OR IMPROVEMENT MADE, CONCEIVED OR ACQUIRED PRIOR TO OR AFTER DELIVERY OF THE EVM.
7. *USER'S INDEMNITY OBLIGATIONS AND REPRESENTATIONS.* USER WILL DEFEND, INDEMNIFY AND HOLD TI, ITS LICENSORS AND THEIR REPRESENTATIVES HARMLESS FROM AND AGAINST ANY AND ALL CLAIMS, DAMAGES, LOSSES, EXPENSES, COSTS AND LIABILITIES (COLLECTIVELY, "CLAIMS") ARISING OUT OF OR IN CONNECTION WITH ANY HANDLING OR USE OF THE EVM THAT IS NOT IN ACCORDANCE WITH THESE TERMS AND CONDITIONS. THIS OBLIGATION SHALL APPLY WHETHER CLAIMS ARISE UNDER STATUTE, REGULATION, OR THE LAW OF TORT, CONTRACT OR ANY OTHER LEGAL THEORY, AND EVEN IF THE EVM FAILS TO PERFORM AS DESCRIBED OR EXPECTED.
8. *Limitations on Damages and Liability:*
- 8.1 *General Limitations.* IN NO EVENT SHALL TI BE LIABLE FOR ANY SPECIAL, COLLATERAL, INDIRECT, PUNITIVE, INCIDENTAL, CONSEQUENTIAL, OR EXEMPLARY DAMAGES IN CONNECTION WITH OR ARISING OUT OF THESE TERMS AND CONDITIONS OR THE USE OF THE EVMS PROVIDED HEREUNDER, REGARDLESS OF WHETHER TI HAS BEEN ADVISED OF THE POSSIBILITY OF SUCH DAMAGES. EXCLUDED DAMAGES INCLUDE, BUT ARE NOT LIMITED TO, COST OF REMOVAL OR REINSTALLATION, ANCILLARY COSTS TO THE PROCUREMENT OF SUBSTITUTE GOODS OR SERVICES, RETESTING, OUTSIDE COMPUTER TIME, LABOR COSTS, LOSS OF GOODWILL, LOSS OF PROFITS, LOSS OF SAVINGS, LOSS OF USE, LOSS OF DATA, OR BUSINESS INTERRUPTION. NO CLAIM, SUIT OR ACTION SHALL BE BROUGHT AGAINST TI MORE THAN ONE YEAR AFTER THE RELATED CAUSE OF ACTION HAS OCCURRED.
- 8.2 *Specific Limitations.* IN NO EVENT SHALL TI'S AGGREGATE LIABILITY FROM ANY WARRANTY OR OTHER OBLIGATION ARISING OUT OF OR IN CONNECTION WITH THESE TERMS AND CONDITIONS, OR ANY USE OF ANY TI EVM PROVIDED HEREUNDER, EXCEED THE TOTAL AMOUNT PAID TO TI FOR THE PARTICULAR UNITS SOLD UNDER THESE TERMS AND CONDITIONS WITH RESPECT TO WHICH LOSSES OR DAMAGES ARE CLAIMED. THE EXISTENCE OF MORE THAN ONE CLAIM AGAINST THE PARTICULAR UNITS SOLD TO USER UNDER THESE TERMS AND CONDITIONS SHALL NOT ENLARGE OR EXTEND THIS LIMIT.
9. *Return Policy.* Except as otherwise provided, TI does not offer any refunds, returns, or exchanges. Furthermore, no return of EVM(s) will be accepted if the package has been opened and no return of the EVM(s) will be accepted if they are damaged or otherwise not in a resalable condition. If User feels it has been incorrectly charged for the EVM(s) it ordered or that delivery violates the applicable order, User should contact TI. All refunds will be made in full within thirty (30) working days from the return of the components(s), excluding any postage or packaging costs.
10. *Governing Law:* These terms and conditions shall be governed by and interpreted in accordance with the laws of the State of Texas, without reference to conflict-of-laws principles. User agrees that non-exclusive jurisdiction for any dispute arising out of or relating to these terms and conditions lies within courts located in the State of Texas and consents to venue in Dallas County, Texas. Notwithstanding the foregoing, any judgment may be enforced in any United States or foreign court, and TI may seek injunctive relief in any United States or foreign court.

Mailing Address: Texas Instruments, Post Office Box 655303, Dallas, Texas 75265
Copyright © 2015, Texas Instruments Incorporated

IMPORTANT NOTICE

Texas Instruments Incorporated and its subsidiaries (TI) reserve the right to make corrections, enhancements, improvements and other changes to its semiconductor products and services per JESD46, latest issue, and to discontinue any product or service per JESD48, latest issue. Buyers should obtain the latest relevant information before placing orders and should verify that such information is current and complete. All semiconductor products (also referred to herein as "components") are sold subject to TI's terms and conditions of sale supplied at the time of order acknowledgment.

TI warrants performance of its components to the specifications applicable at the time of sale, in accordance with the warranty in TI's terms and conditions of sale of semiconductor products. Testing and other quality control techniques are used to the extent TI deems necessary to support this warranty. Except where mandated by applicable law, testing of all parameters of each component is not necessarily performed.

TI assumes no liability for applications assistance or the design of Buyers' products. Buyers are responsible for their products and applications using TI components. To minimize the risks associated with Buyers' products and applications, Buyers should provide adequate design and operating safeguards.

TI does not warrant or represent that any license, either express or implied, is granted under any patent right, copyright, mask work right, or other intellectual property right relating to any combination, machine, or process in which TI components or services are used. Information published by TI regarding third-party products or services does not constitute a license to use such products or services or a warranty or endorsement thereof. Use of such information may require a license from a third party under the patents or other intellectual property of the third party, or a license from TI under the patents or other intellectual property of TI.

Reproduction of significant portions of TI information in TI data books or data sheets is permissible only if reproduction is without alteration and is accompanied by all associated warranties, conditions, limitations, and notices. TI is not responsible or liable for such altered documentation. Information of third parties may be subject to additional restrictions.

Resale of TI components or services with statements different from or beyond the parameters stated by TI for that component or service voids all express and any implied warranties for the associated TI component or service and is an unfair and deceptive business practice. TI is not responsible or liable for any such statements.

Buyer acknowledges and agrees that it is solely responsible for compliance with all legal, regulatory and safety-related requirements concerning its products, and any use of TI components in its applications, notwithstanding any applications-related information or support that may be provided by TI. Buyer represents and agrees that it has all the necessary expertise to create and implement safeguards which anticipate dangerous consequences of failures, monitor failures and their consequences, lessen the likelihood of failures that might cause harm and take appropriate remedial actions. Buyer will fully indemnify TI and its representatives against any damages arising out of the use of any TI components in safety-critical applications.

In some cases, TI components may be promoted specifically to facilitate safety-related applications. With such components, TI's goal is to help enable customers to design and create their own end-product solutions that meet applicable functional safety standards and requirements. Nonetheless, such components are subject to these terms.

No TI components are authorized for use in FDA Class III (or similar life-critical medical equipment) unless authorized officers of the parties have executed a special agreement specifically governing such use.

Only those TI components which TI has specifically designated as military grade or "enhanced plastic" are designed and intended for use in military/aerospace applications or environments. Buyer acknowledges and agrees that any military or aerospace use of TI components which have **not** been so designated is solely at the Buyer's risk, and that Buyer is solely responsible for compliance with all legal and regulatory requirements in connection with such use.

TI has specifically designated certain components as meeting ISO/TS16949 requirements, mainly for automotive use. In any case of use of non-designated products, TI will not be responsible for any failure to meet ISO/TS16949.

Products

Audio	www.ti.com/audio
Amplifiers	amplifier.ti.com
Data Converters	dataconverter.ti.com
DLP® Products	www.dlp.com
DSP	dsp.ti.com
Clocks and Timers	www.ti.com/clocks
Interface	interface.ti.com
Logic	logic.ti.com
Power Mgmt	power.ti.com
Microcontrollers	microcontroller.ti.com
RFID	www.ti-rfid.com
OMAP Applications Processors	www.ti.com/omap
Wireless Connectivity	www.ti.com/wirelessconnectivity

Applications

Automotive and Transportation	www.ti.com/automotive
Communications and Telecom	www.ti.com/communications
Computers and Peripherals	www.ti.com/computers
Consumer Electronics	www.ti.com/consumer-apps
Energy and Lighting	www.ti.com/energy
Industrial	www.ti.com/industrial
Medical	www.ti.com/medical
Security	www.ti.com/security
Space, Avionics and Defense	www.ti.com/space-avionics-defense
Video and Imaging	www.ti.com/video

TI E2E Community

e2e.ti.com