

QUICK START GUIDE FOR DEMONSTRATION CIRCUIT 1053E through 1053H SYNCHRONOUS BOOST DC/DC CONVERTER

LTC3526L/LTC3526LB/LTC3526L-2/LTC3526LB-2

DESCRIPTION

Demonstration circuits 1053A-E through 1053A-H are high efficiency synchronous boost converters capable of operating with an input voltage range from 0.8V to 5.5V. The 2X2 mm DFN thermally enhanced package with a 1MHz switching frequency (2MHz for -2 versions) and the 550mA internal switches provide a very tiny solution. The LTC3526L family also features output disconnect and the input voltage can be greater or less than the output voltage.

This demonstration circuit allows the user to quickly evaluate the LTC3526L performance. Individual jumpers are provided for selecting several regulated output voltages and a low quiescent current shutdown. Terminals on the board allow easy hookup to an input supply and output load.

Design files for this circuit board are available. Call the LTC factory.

LTC and Burst Mode are trademarks of Linear Technology Corporation

Table 1. Typical Specifications (25 °C)

Input Voltage Range V_{IN}		0.8V to 5V
1.8V V_{OUT}	$V_{IN} = 1V, I_{OUT} = 100mA$	$1.8V \pm 2.5\%$
3.3V V_{OUT}	$V_{IN} = 1.5V, I_{OUT} = 100mA$	$3.3V \pm 2.5\%$
5V V_{OUT}	$V_{IN} = 1.5V, I_{OUT} = 100mA$	$5.0V \pm 2.5\%$
Output Ripple Voltage (burst mode)	$V_{IN} = 1.2V, V_{OUT} = 1.8V, I_{OUT} = 1mA$	45mV p-p
Output Ripple Voltage (fixed frequency)	$V_{IN} = 1.2V, V_{OUT} = 1.8V, I_{OUT} = 100mA$	10mV p-p
Efficiency (1 MHz)	$V_{IN} = 1.2V, V_{OUT} = 1.8V, I_{OUT} = 50mA$	85%
Efficiency (1 MHz)	$V_{IN} = 2.5V, V_{OUT} = 3.3V, I_{OUT} = 50mA$	92%

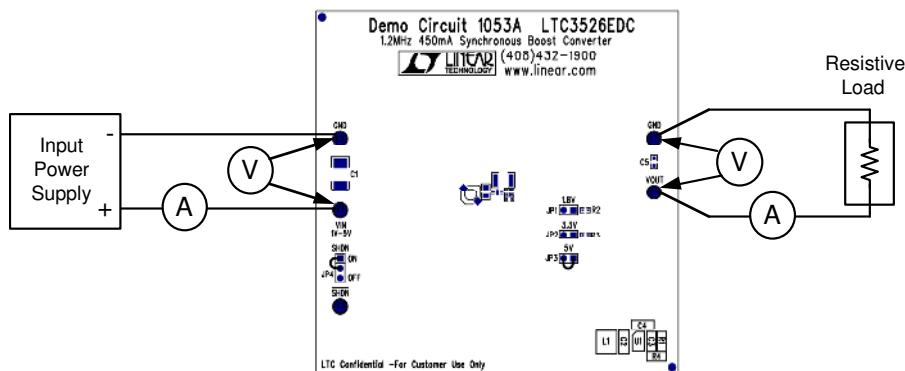

Figure 1. Demonstration Circuit Test Setup

QUICK START GUIDE FOR DEMONSTRATION CIRCUIT 1053E through 1053H SYNCHRONOUS BOOST DC/DC CONVERTER

Table 2. Demonstration Circuit Board Information

Board Number	LTC Part Number	Part Marking	Frequency	Inductor	Mode	Action
1053A-A	LTC3526EDC	LCHW	1MHz	4.7 μ H	Burst	Discontinued, use 1053A-E
1053A-B	LTC3526BEDC	LCNN	1MHz	4.7 μ H	No Burst	Discontinued, use 1053A-F
1053A-C	LTC3526EDC-2	LCNM	2MHz	2.2 μ H	Burst	Discontinued, use 1053A-G
1053A-D	LTC3526BEDC-2	LCNP	2MHz	2.2 μ H	No Burst	Discontinued, use 1053A-H
1053A-E	LTC3526LEDC	LCSS	1MHz	4.7 μ H	Burst	
1053A-F	LTC3526LBEDC	LCST	1MHz	4.7 μ H	No Burst	
1053A-G	LTC3526LEDC-2	LFFC	2MHz	2.2 μ H	Burst	
1053A-H	LTC3526LBEDC-2	LFFD	2MHz	2.2 μ H	No Burst	

QUICK START PROCEDURE

There is one demonstration circuit board for all four LTC3526L versions. The boards are identified by the handwritten information on the top of the pc board.

The boost converter can be evaluated using the setup shown in Figure 1. Select one of the three output voltages using jumpers JP1 through JP3. (With no jumpers installed, the output voltage is 5V.) Set jumper JP4 in the ON position and connect voltmeters and ammeters as shown on the test setup. Connect a power supply to the V_{IN} and GND terminals and a suitable load resistor between VOUT and GND.

With a light load (1k resistor) at the output, begin increasing the input power supply voltage. At approximately 750mV the output will rise to the selected regulated voltage. Increase the input voltage to approximately 1.5V and increase the load current. Move output voltage jumpers and verify output voltage.

Note the excellent load regulation when going from a light load current to a heavier load, but it is important to monitor the input voltage directly at the input terminals of the circuit

board. At very low input voltages, voltage drops in the power supply wire; connections and Ammeter will result in the input voltage at the input terminals dropping below the minimum voltage required for operation.

The input voltage can exceed the output voltage and still maintain regulation, although the load current is less and efficiency is lower. It should be noted that under some load current conditions, the output voltage ripple could increase as V_{in} approaches V_{out} . The increase will occur in a narrow range when V_{in} is between 100 and 300mV below V_{out} . The ripple voltage in this range can be from 30mV to 100mV pp. Increasing output capacitance will reduce this ripple.

Due to the high inductor current slew rate in 5V output applications, the 2MHz LTC3526L-2 may not enter burst mode for input voltages less than 1.4V. For 5V applications requiring burst mode, the 1MHz LTC3526L is recommended. Refer to the Typical Performance Characteristics curves for the burst mode thresholds for different input and output voltages.

QUICK START GUIDE FOR DEMONSTRATION CIRCUIT 1053A-E THROUGH 1053A-H SYNCHRONOUS BOOST DC/DC CONVERTER

Additional pc board pads are provided for an optional input bypass capacitor (C1). A capacitor maybe necessary when using long wires between the power supply and circuit board, or for adding a tantalum capacitor to minimize input voltage transients that may occur when the input is hot-switched. Also, pads on the board backside are provided for adding a small Schottky diode (D1) that can increase

efficiency slightly under some conditions. But adding a diode defeats the output disconnect and short circuit protection features.

When verifying output ripple, it is important to use the scope probe connection as shown in figure 2.

See the appropriate LTC3526L Data Sheet for additional information.

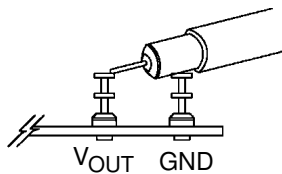
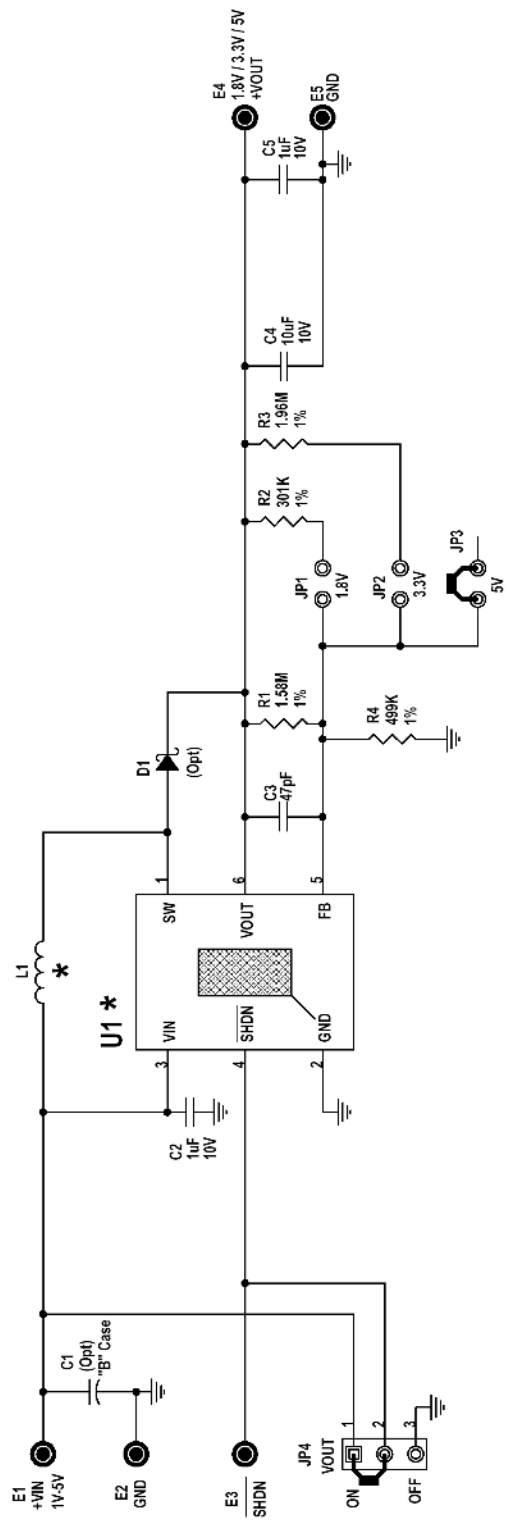

Figure 2. Scope Probe Placement for Measuring Output Ripple Voltage

QUICK START GUIDE FOR DEMONSTRATION CIRCUIT 1053A-E THROUGH 1053A-H SYNCHRONOUS BOOST DC/DC CONVERTER

This circuit is proprietary to Linear Technology and supplied for use with Linear Technology parts.
Customer Notice: Linear Technology has made a best effort to design a circuit that meets customer-supplied specifications; however, it remains the customer's responsibility to verify proper and reliable operation in the actual application. Component substitution and printed circuit board layout may significantly affect circuit performance or reliability. Contact Linear Applications Engineering for assistance.



BOARD ASSEMBLY

	U1*	L1*	freq	Mode
DC1053A-E	LTC3526LEDC	4.7uH	1MHz	Burst
DC1053A-F	LTC3526LEDC	4.7uH	1MHz	No Burst
DC1053A-G	LTC3526LEDC-2	2.2uH	2MHz	Burst
DC1053A-H	LTC3526LEDC-2	2.2uH	2MHz	No Burst

APPROVALS		LINEAR TECHNOLOGY CORPORATION 1630 McCARTHY BLVD MILPITAS, CA, 95035 www.linear.com	
DRAWN: Rudy Bautista		LTC Confidential - For Customer Use Only	
ENGINEER: Fran Hoffart		Title: LTC3526L 500mA Synchronous Boost Converter	
APPROVED:		Document Number	
CHECKED:		Demo Circuit 1053A	
Date: Thursday, June 11, 2009	C:\ORCAD\WINCAPTURE\1053A\01_REV5.DSN	Sheet 1 of 1	Rev 5

REVISION HISTORY			
REVISION #	PC	AD	FD
0	0	0	0
2	—	—	—
3	—	—	—
4	2	3	2
5	2	4	2

DESCRIPTION	DATE	APPROVED
1st Release	12/01/06	F. Hoffart
R4 from 1.10M to 1.07M	08/17/07	F. Hoffart
Value Change R1,R2,R3,R4 & C3	04/02/09	F. Hoffart
Add "E" Version	06/05/09	F. Hoffart
Add "F" to "H" Version		
Obsolete "A" and "C" Version.		
Obsolete "B" and "D" Version.		