

TABLE OF CONTENTS

SECTION	PAGE
1.0 SCOPE.....	2
2.0 PURPOSE.....	2
3.0 GENERAL.....	2
4.0 PACKAGING OF CONNECTORS AND LOOSE CAPS.....	3
5.0 PACKAGING OF CAPPED CONNECTORS.....	5
6.0 LABELLING.....	7

REVISION:	ECR/ECN INFORMATION:	TITLE:	SHEET No.
E	EC No: 123332 DATE: 13-Oct- <small>2017001710/000</small>	QF50 SINGLE BEAM FEMALE ASSEMBLY 90635 SERIES	1 of 7
DOCUMENT NUMBER:	CREATED / REVISED BY:	CHECKED BY:	APPROVED BY:
PK-90635-001	SOREGAN	PODWYERPODWYER	DMAHERDMAHER

1.0 SCOPE

This specification specifies the requirements for the packaging of the 90635 product series.

2.0 PURPOSE

The purpose of this specification is to assure that all 90635 product shipped from Molex arrives damage free and in a manner that allows ease of handling, storage and distribution.

3.0 GENERAL

The 90635-0*** connector options are packed into tubes without the caps. The caps are packed loose in bags. The connectors and the caps are shipped in the same carton.

The 90635-1*** and 9*** connector options are supplied with the caps inserted onto the connector in the pre-load position and packed into trays.

The carton weight should not exceed 15kg.

REVISION: E	ECR/ECN INFORMATION: EC No: 123332 DATE: 13-Oct-2017 09:17:40/000	TITLE: QF50 SINGLE BEAM FEMALE ASSEMBLY 90635 SERIES	SHEET No. 2 of 7
DOCUMENT NUMBER: PK-90635-001	CREATED / REVISED BY: SOREGAN	CHECKED BY: PODWYERPODWYER	APPROVED BY: DMAHERDMAHER

4.0 PACKAGING OF CONNECTORS AND LOOSE CAPS

The connectors (part no. 90635-0***) are packaged in tubes (part no. 99024-0057) without caps. 90 full tubes have their ends taped (part no. 96717-0002) and are placed into outer carton (part no. 91687-0064) in rows 10 tubes wide by 9 rows high. Four layers of bubble wrap are placed on top of the tubing.

The caps (part no. 90633-00**) are packed in a bag (part no. 96713-0004). The bag is heat sealed and placed into the outer carton (part no. 91687-0064) on top of the bubble wrap.

Eight layers of bubble wrap are placed on top of the bag containing the caps. The outer carton is sealed and the label is applied to the end of it.

See table 1 below for BOM.

See table 2 below for details on connector and cap quantities.

Table 1

ITEM	PART NUMBER	QUANTITY	DESCRIPTION
1	91687-0064	1	OUTER CARTON
2	99024-0057	90	TUBE
3	96717-0002	180	END TAPE
4	96713-0004	1	POLYETHYLENE BAG
5	90635-0***	SEE TABLE 2	CONNECTOR & CAP

REVISION: E	ECR/ECN INFORMATION: EC No: 123332 DATE: 13-Oct-2017	TITLE: QF50 SINGLE BEAM FEMALE ASSEMBLY 90635 SERIES	SHEET No. 3 of 7
DOCUMENT NUMBER: PK-90635-001	CREATED / REVISED BY: SOREGAN	CHECKED BY: PODWYERPODWYER	APPROVED BY: DMAHERDMAHER

Table 2

PART NUMBER	CKT SIZE	CONNECTORS PER TUBE	CONNECTORS PER CARTON	CAPS PER BAG	CAPS PER CARTON
90635-010*	10	36	3240	3240	3240
90635-014*	14	26	2340	2340	2340
90635-016*	16	24	2160	2160	2160
90635-020*	20	18	1620	1620	1620
90635-024*	24	16	1440	1440	1440
90635-026*	26	14	1260	1260	1260
90635-030*	30	12	1080	1080	1080
90635-034*	34	12	1080	1080	1080
90635-040*	40	10	900	900	900
90635-050*	50	8	720	720	720
90635-060*	60	7	630	630	630
90635-064*	64	6	540	540	540

REVISION: E	ECR/ECN INFORMATION: EC No: 123332 DATE: 13-Oct-2017	TITLE: QF50 SINGLE BEAM FEMALE ASSEMBLY 90635 SERIES	SHEET No. 4 of 7
DOCUMENT NUMBER: PK-90635-001	CREATED / REVISED BY: SOREGAN	CHECKED BY: PODWYERPODWYER	APPROVED BY: DMAHERDMAHER

5.0 PACKAGING OF CAPPED CONNECTORS

The capped connectors (part no. 90635-1*** and 9***) are packaged in trays (part no. 99025-0051). 20 full trays are stacked into each other and 1 empty tray placed on top.

A cardboard spacer (part no. 96720-0002) is placed on the top and bottom of the stack and secured in place using 2 rubber bands (part no. 99990187).

Bubble wrap (part no. 99995400) is placed around the stack which is then placed in the carton (part no. 96707-0001).

The carton is closed and secured with tape. The label is applied to the end of the carton.

See table 3 below for BOM.

See table 4 below for details on connector quantities.

Table 3

ITEM	PART NUMBER	QUANTITY	DESCRIPTION
1	96707-0001	1	CARTON
2	99025-0051	21	TRAY
3	96720-0002	2	CARDBOARD SPACER
4	99990187	2	RUBBER BAND
5	99995400	1	BUBBLE WRAP
6	90635-1*** and 9***	SEE TABLE 4	CONNECTOR & CAP

REVISION: E	ECR/ECN INFORMATION: EC No: 123332 DATE: 13-Oct-2017	TITLE: QF50 SINGLE BEAM FEMALE ASSEMBLY 90635 SERIES	SHEET No. 5 of 7
DOCUMENT NUMBER: PK-90635-001	CREATED / REVISED BY: SOREGAN	CHECKED BY: PODWYERPODWYER	APPROVED BY: DMAHERDMAHER

Table 4

PART NUMBER	CKT SIZE	CONNECTORS PER TRAY	CONNECTORS PER CARTON
90635-110* & -910*	10	114	2280
90635-114* & -914*	14	86	1720
90635-116* & -916*	16	78	1560
90635-120* & -920*	20	66	1320
90635-124* & -924*	24	54	1080
90635-126* & -926*	26	50	1000
90635-130* & -930*	30	44	880
90635-134* & -934*	34	38	760
90635-140* & -940*	40	36	720
90635-150* & -950*	50	26	520
90635-160* & -960*	60	24	480
90635-164* & -964*	64	20	400

REVISION: E	ECR/ECN INFORMATION: EC No: 123332 DATE: 13-Oct-2017	TITLE: QF50 SINGLE BEAM FEMALE ASSEMBLY 90635 SERIES	SHEET No. 6 of 7
DOCUMENT NUMBER: PK-90635-001	CREATED / REVISED BY: SOREGAN	CHECKED BY: PODWYERPODWYER	APPROVED BY: DMAHERDMAHER

6.0 LABELLING

The labels used are standard Molex Ireland labels and measure 127.0 x 76.2 mm, see example below.

(P) PART NUMBER 0906350142		
		
DESCRIPTION 1.27mm QF50 Rec Vt Polz .76Au 14Ckt		
(Q) QUANTITY 2880		
		
(12D) INV CTRL DATE 2005/12/09		
(4L) COUNTRY OF ORIGIN Ireland		
(S) TRACKING NO 000813573441		
		
ELV and RoHS Compliant		
Packing Standards	3060	OUTER
Eng.Nr.	906350142	ASM1 1/1
Molex P/N (P)	0906350142	
		 www.molex.com
Molex Ireland Ltd., Shannon Industrial Estate, Shannon, Co.Clare, Ireland		

Labels are placed on the outer carton (if applicable) as per the sketch below

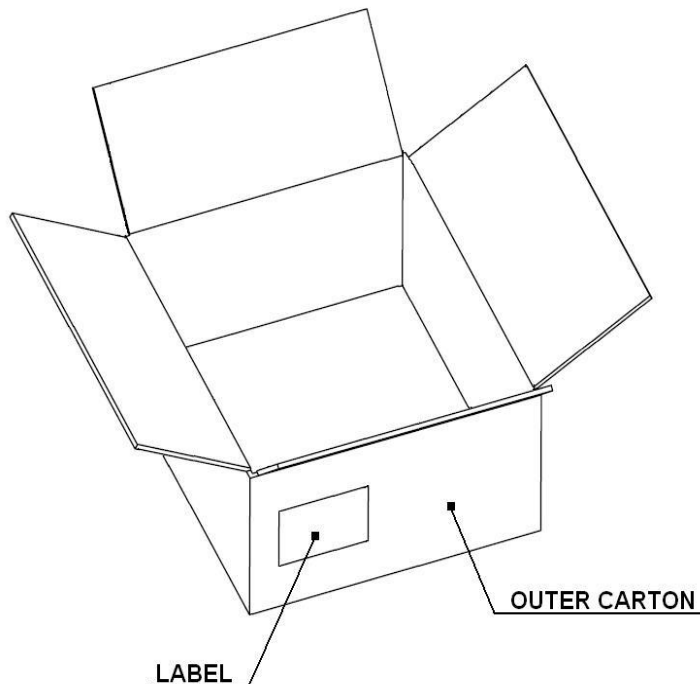

REVISION: E	ECR/ECN INFORMATION: EC No: 123332 DATE: 13-Oct-2005	TITLE: QF50 SINGLE BEAM FEMALE ASSEMBLY 90635 SERIES	SHEET No. 7 of 7
DOCUMENT NUMBER: PK-90635-001	CREATED / REVISED BY: SOREGAN	CHECKED BY: PODWYERPODWYER	APPROVED BY: DMAHERDMAHER