

EJECTION LATCHES OMITTED IN THIS VIEW FOR CLARITY

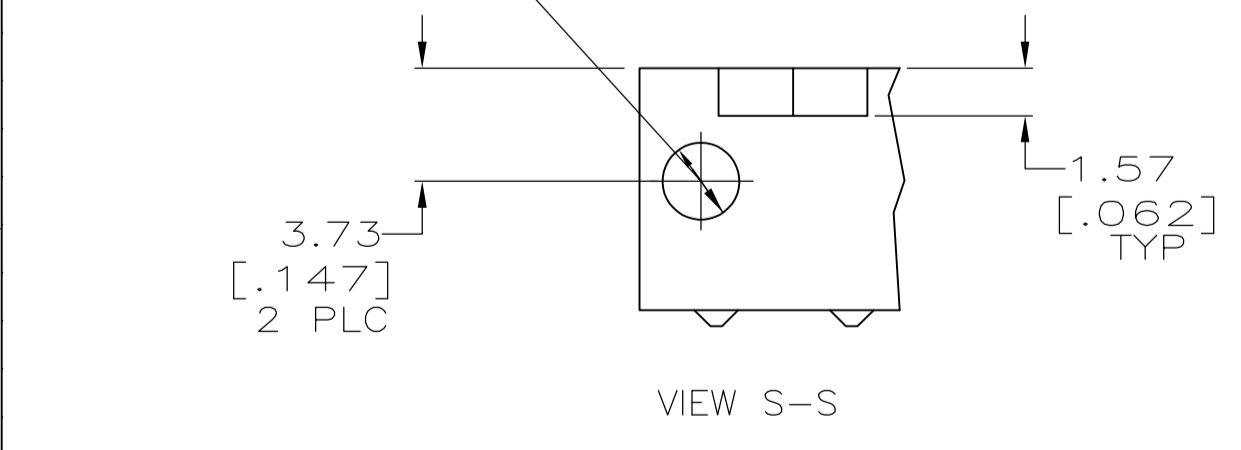
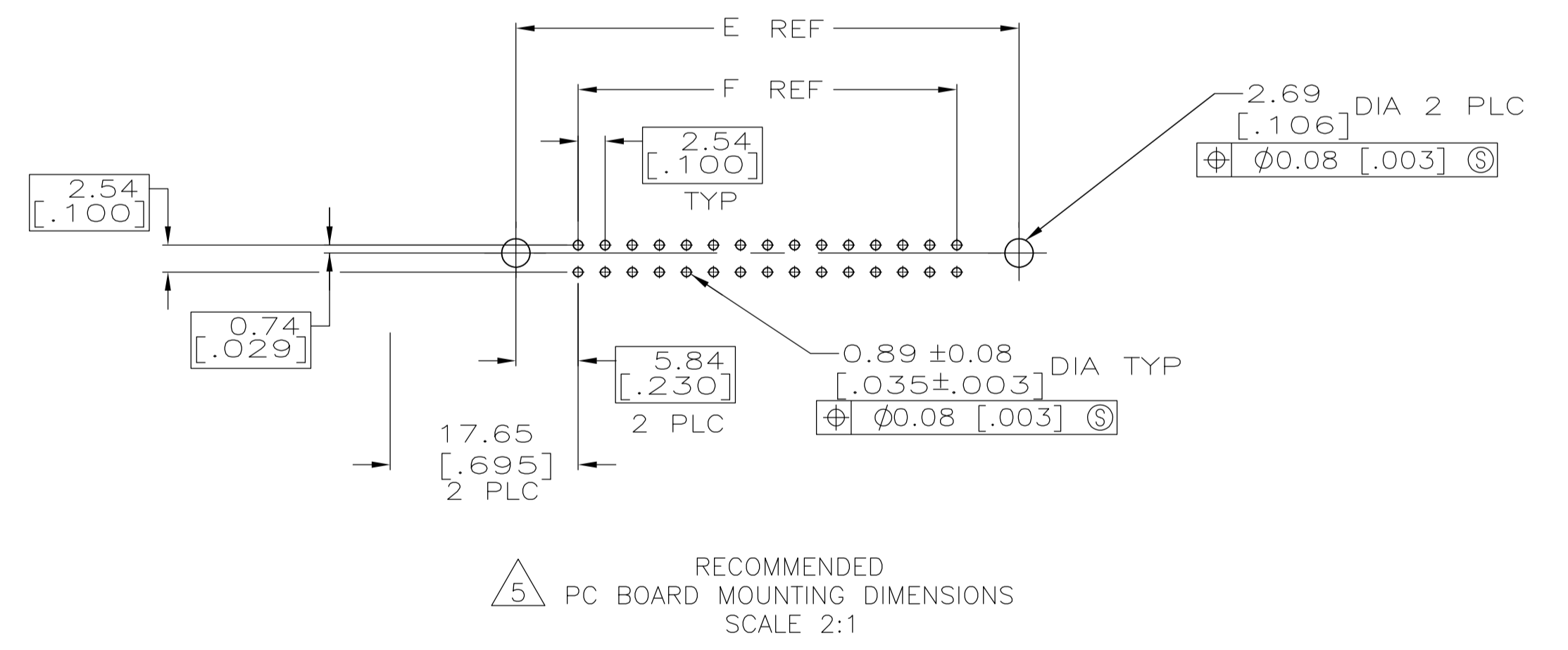
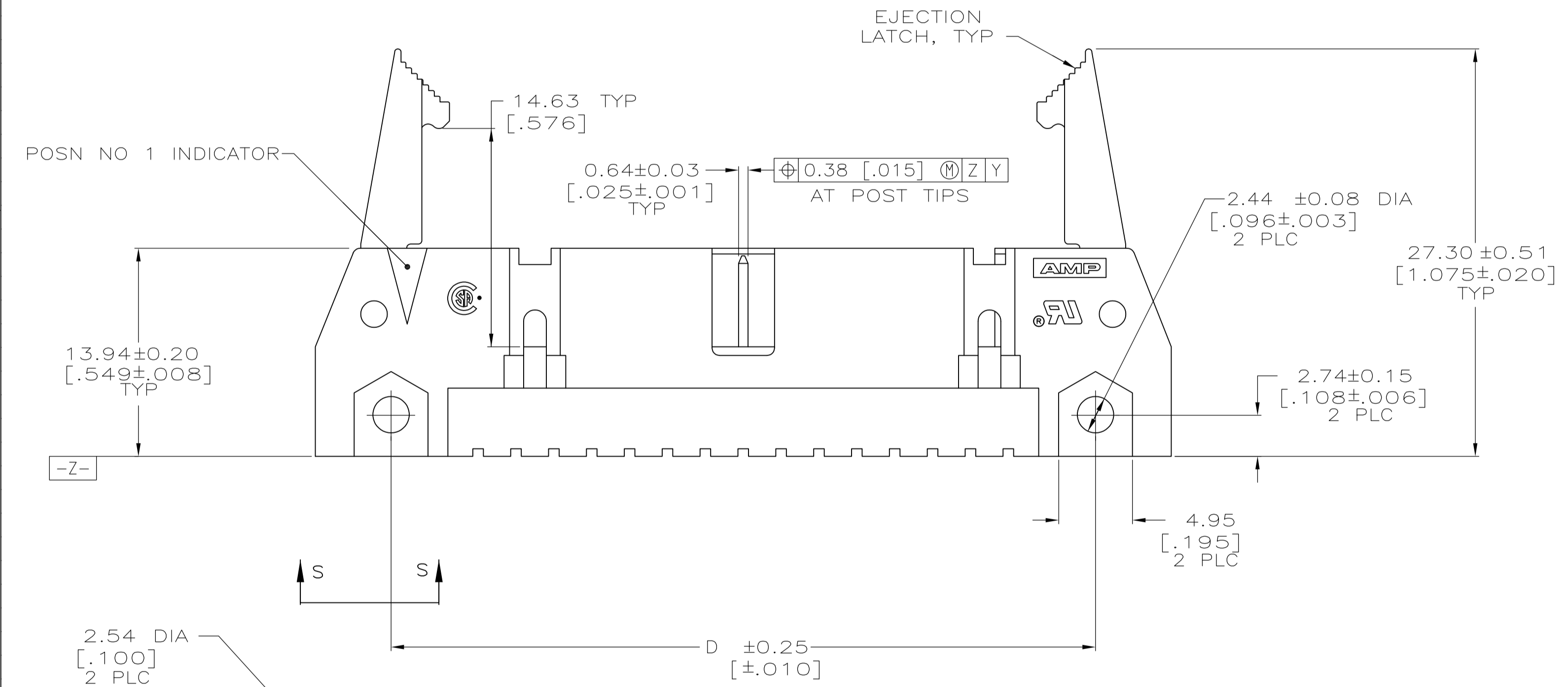
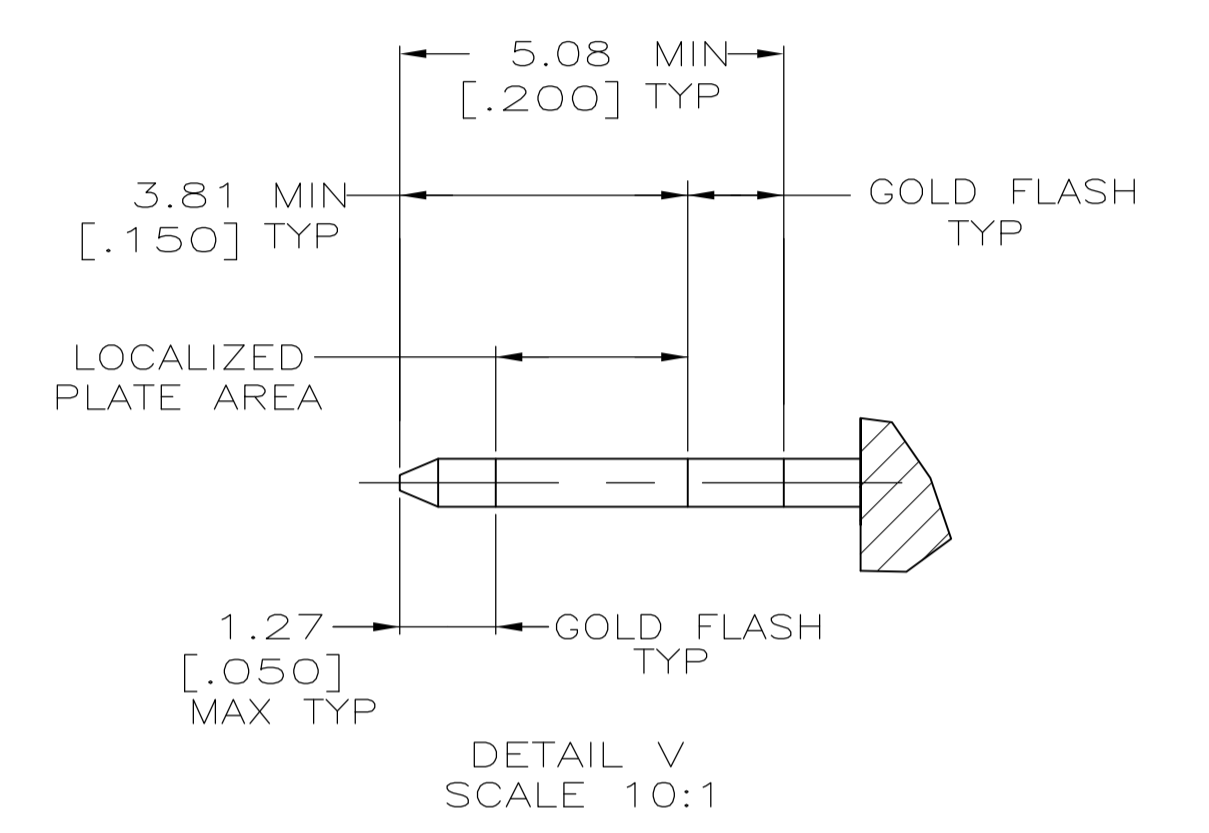
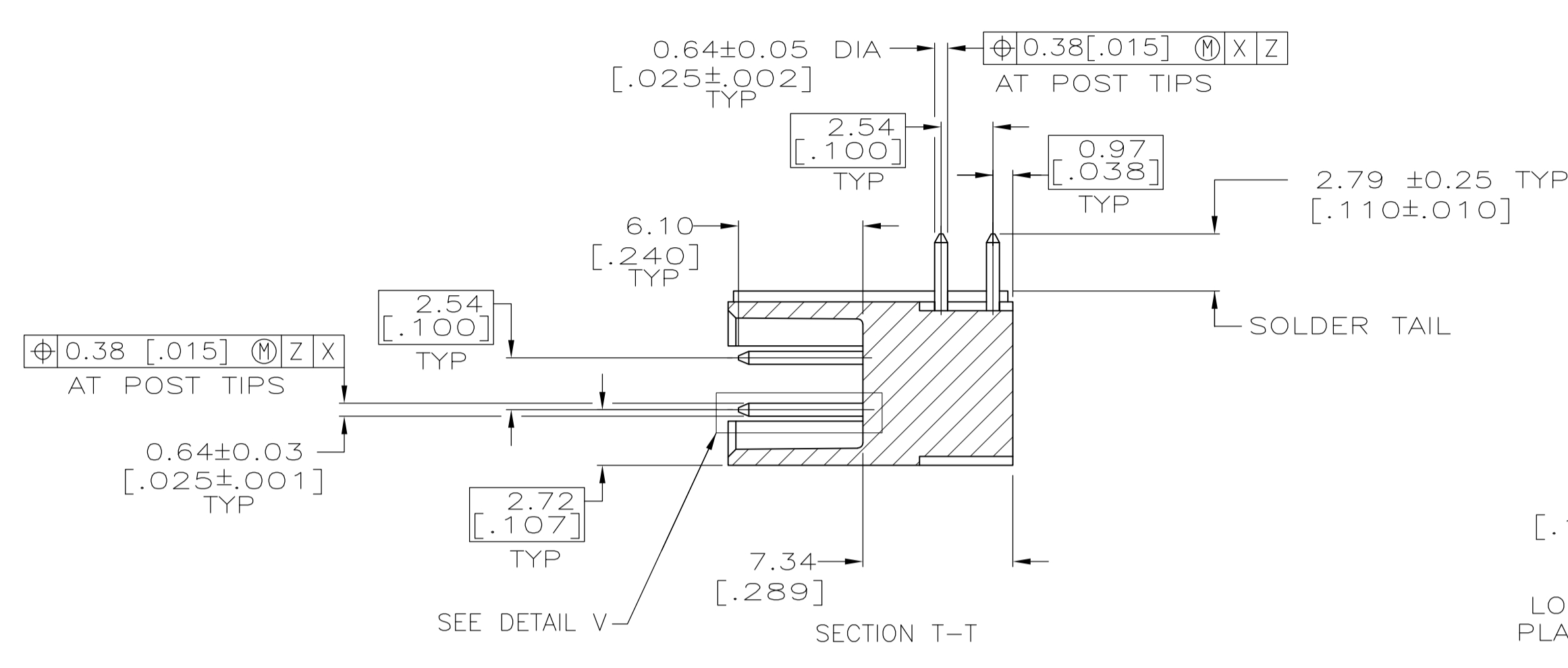
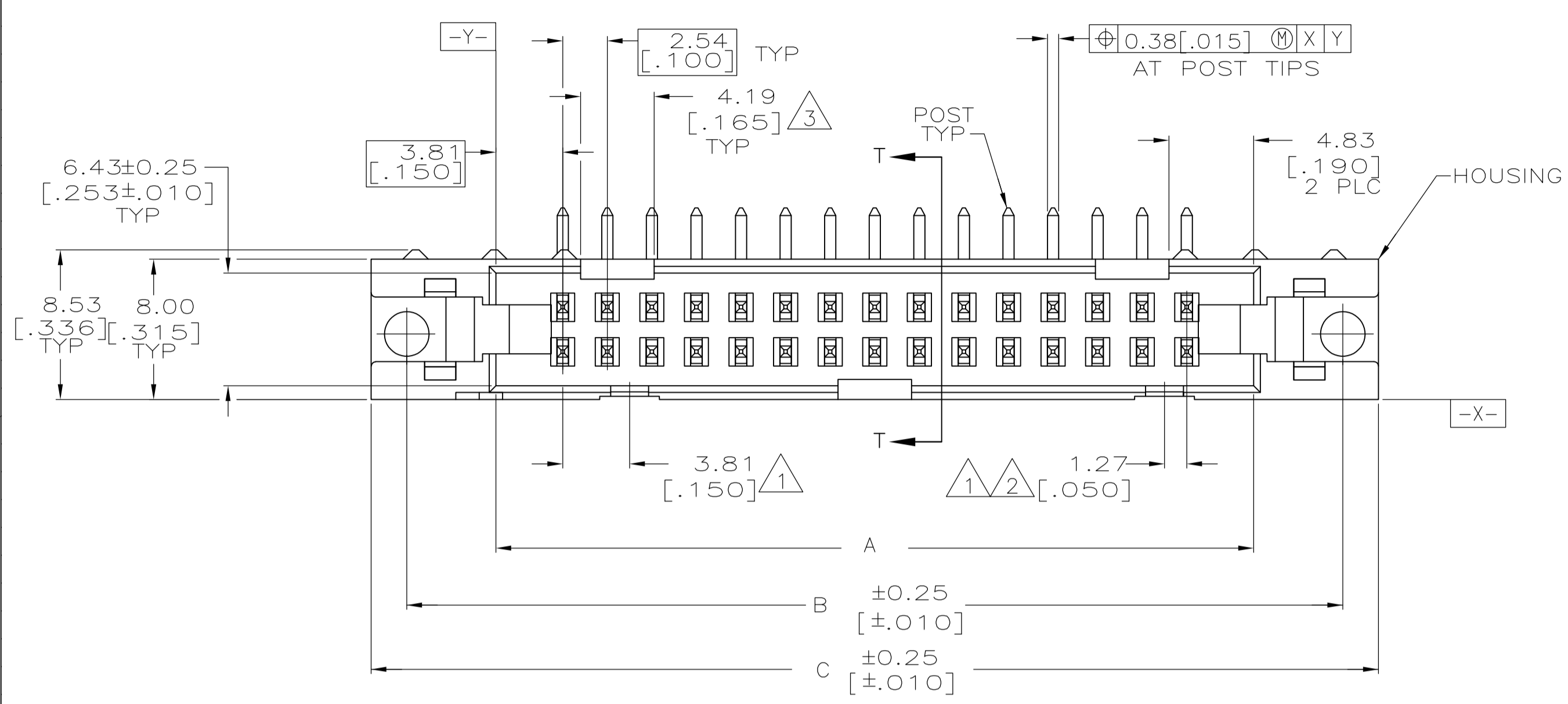

THIS DRAWING IS A CONTROLLED DOCUMENT.		DIN H.MOLL 4-23-90	<b>STE</b> TE Connectivity	
TOLERANCES UNLESS OTHERWISE SPECIFIED:		CHK R.STONE 11-28-90		
DIMENSIONS: mm [INCHES]	0 PLC ± -	APVD -	NAME	
	1 PLC ± -	PRODUCT SPEC		
	2 PLC ± 0.13[.005]	108-40018		
	3 PLC ± -	APPLICATION SPEC		
	4 PLC ± -	SIZE	CAGE CODE	DRAWING NO
	ANGLES ± -	A1	00779	499786
MATERIAL SEE SHEET 2	FINISH SEE SHEET 2	WEIGHT	CUSTOMER DRAWING	
		SCALE	SHEET	REV
		4:1	1 OF 2	J1

- ① COORDINATE DIMENSION APPLIES FROM BASIC LOCATION.
- ② 10 AND 14 POSITION SIZES CONTAIN ONLY ONE SLOT FOR SNAP-IN POLARIZER (MILITARY POLARIZATION) LOCATED AS SHOWN.
- ③ 10 POSITION SIZES CONTAIN ONLY ONE SLOT FOR DUAL POLARIZATION, LOCATED AS SHOWN.
- 4. RECOMMENDED PRINTED CIRCUIT BOARD THICKNESS IS 1.57 [.062].
- ⑤ DISTANCE REQUIRED BY EJECTION LATCHES IN THE OPEN POSITION.
- ⑥ POSTS:  
GOLD FLASH OVER PALLADIUM-NICKEL PLATE, 0.38μm [.000015] MIN TOTAL ON THE LOCALIZED PLATE AREA,  
2.54μm [.000100] MIN TIN-LEAD PLATE ON THE SOLDER-TAIL,  
1.27μm [.000050] MIN NICKEL UNDERPLATE ON THE ENTIRE POST.  
OR  
0.38μm [.000015] MIN GOLD PLATE ON THE LOCALIZED PLATE AREA,  
2.54μm [.000100] MIN TIN-LEAD PLATE ON THE SOLDER-TAIL,  
1.27μm [.000050] MIN NICKEL UNDERPLATE ON THE ENTIRE POST.
- ⑦ MATERIAL:  
HOUSING: GLASS FILLED NYLON OR POLYESTER, 94V-0 RATED, BLACK.  
POSTS: BRASS.

OBSOLETE	53.34	65.02	65.02	75.18	71.12	60.96	44	1-499786-3
	[2.100]	[2.560]	[2.560]	[2.960]	[2.800]	[2.400]		
	78.74	90.42	90.42	100.58	96.52	86.36	64	1-499786-2
	[3.100]	[3.560]	[3.560]	[3.960]	[3.800]	[3.400]		
	73.66	85.34	85.34	95.50	91.44	81.28	60	1-499786-1
	[2.900]	[3.360]	[3.360]	[3.760]	[3.600]	[3.200]		
	60.96	72.64	72.64	82.80	78.74	68.58	50	1-499786-0
	[2.400]	[2.860]	[2.860]	[3.260]	[3.100]	[2.700]		
	48.26	59.94	59.94	70.10	66.04	55.88	40	499786-9
	[1.900]	[2.360]	[2.360]	[2.760]	[2.600]	[2.200]		
	40.64	52.32	52.32	62.48	58.42	48.26	34	499786-8
	[1.600]	[2.060]	[2.060]	[2.460]	[2.300]	[1.900]		
OBSOLETE	35.56	47.24	47.24	57.40	53.34	43.18	30	499786-7
	[1.400]	[1.860]	[1.860]	[2.260]	[2.100]	[1.700]		
	30.48	42.16	42.16	52.32	48.26	38.10	26	499786-6
	[1.200]	[1.660]	[1.660]	[2.060]	[1.900]	[1.500]		
	27.94	39.62	39.62	49.78	45.72	35.56	24	499786-5
	[1.100]	[1.560]	[1.560]	[1.960]	[1.800]	[1.400]		
	22.86	34.54	34.54	44.70	40.64	30.48	20	499786-4
	[.900]	[1.360]	[1.360]	[1.760]	[1.600]	[1.200]		
OBSOLETE	17.78	29.46	29.46	39.62	35.56	25.40	16	499786-3
	[.700]	[1.160]	[1.160]	[1.560]	[1.400]	[1.000]		
	15.24	26.92	26.92	37.08	33.02	22.86	14	499786-2
	[.600]	[1.060]	[1.060]	[1.460]	[1.300]	[.900]		
	10.16	21.84	21.84	32.00	27.94	17.78	10	499786-1
	[.400]	[.860]	[.860]	[1.260]	[1.100]	[.700]		
	F	E	D	C	B	A	NO OF POSN	PART NUMBER

THIS DRAWING IS A CONTROLLED DOCUMENT.		DIN 4-23-90	H. MOLL	
DIMENSIONS: mm [INCHES]		11-28-90	R. STONE	
TOLERANCES UNLESS OTHERWISE SPECIFIED:		NAME		
0 PLC ± -	1 PLC ± -	PRODUCT SPEC		
2 PLC ± 0.13[.005]	3 PLC ± -	108-40018		
4 PLC ± -	ANGLES ± -	APPLICATION SPEC		
MATERIAL	FINISH	SIZE	CAGE CODE	DRAWING NO
⑦	⑥	A1	00779	499786
CUSTOMER DRAWING		SCALE	SHEET	REV
		4:1	2 OF 2	J1