

IndustrialNet™ USB Coupler

PANDUIT®

SPECIFICATION SHEET

specifications

Industrial USB couplers shall be applicable for use in manufacturing environments and shall comply with the USB 2.0 specification. Bulkhead USB coupler shall incorporate an IP67 rated seal and shall be designed to provide protection from dust, washdown, and temporary immersion in water typically found in harsh industrial environments. Tethered protective cap shall ensure IP67 protection of the coupler in the unmated condition.



technical information

Performance:	Complies with USB 2.0 specification and is backwards compatible to USB 1.1 specification
Environmental protection:	Protects and seals connections against dust, washdown, and water immersion to ANSI/IEC 60529-2004; includes protective cap; vibration, temperature, and chemical resistant
c(UL)US listed:	UL 1863, CSA C22.2 standard
RoHs compliant :	Compliant

key features and benefits

Connector mounting nut	Secures bulkhead from inside of enclosure
Bayonet style interface	Provides positive reinforcement during mated condition; rated to 100 mating cycles
Standard mounting	Compatible with standard IEC 1-13/64" (30.5mm) diameter enclosure opening with panel thickness of 0.035 in. (0.89mm) to 0.135 in. (3.43mm)
Protective cap	Maintains IP67 seal during un-mated conditions
Optional tamper-resistant	Removable and permanent blockout devices block unauthorized access to USB Type 'A' ports, to provide additional security from viruses being loaded and data being removed through the USB port

applications

The IndustrialNet™ USB Coupler is a key component in an overall Industrial data communications application. In most designs, the bulkhead connector provides a communication path to devices within a control panel. Typically used in work cells requiring the IP67 protection, where wash down is needed. This is common in the food and beverage industry where bacterial contamination is present.

The bulkhead connector also offers high temperature resilience, namely 185°F (85°C) storage temperature and 158°F (70°C) operating temperature. In manufacturing facilities such as metal processing, welding, and chemical batch processing, high temperatures are normal. Vibration is also a concern, as in automotive panel stamping plants and work cells.

IndustrialNet™ USB Coupler

Female A to female A: IAEBHUSBAA

IndustrialNet™ Stainless Steel Faceplates

Single gang: IAEEP1
Double gang: IAEP2-2G

USB Type 'A' Blockout Devices

USB Type 'A' Blockout

Device: PSL-USBA^

Permanent

USB Type 'A' Blockout

Device: PSL-PERM-USBA^^

^PSL-USBA standard package includes five blockout devices and one removal tool.
^^PSL-PERM-USBA standard package includes ten blockout devices.

Bulk packages available, contact customer service.

For additional IndustrialNet™ Components, visit www.panduit.com or contact customer service.

IndustrialNet™ USB Coupler

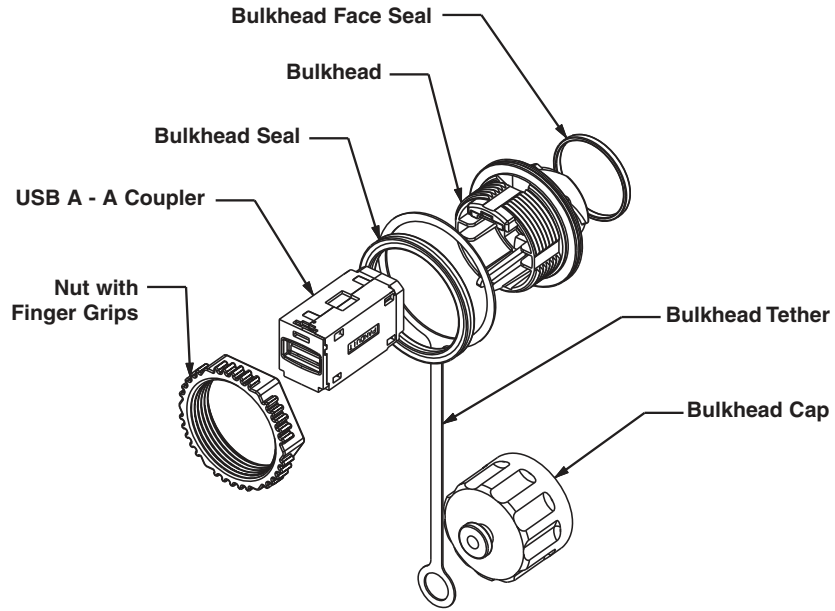
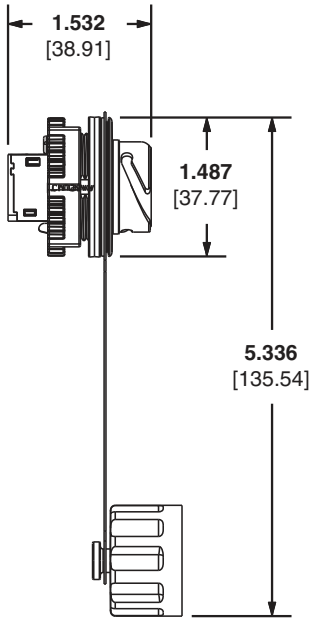

Dimensions are in inches. [Dimensions in brackets are metric].

WORLDWIDE SUBSIDIARIES AND SALES OFFICES

PANDUIT CANADA
Markham, Ontario
cs-cdn@panduit.com
Phone: 800.777.3300

PANDUIT EUROPE LTD.
London, UK
cs-emea@panduit.com
Phone: 44.20.8601.7200

PANDUIT SINGAPORE PTE. LTD.
Republic of Singapore
cs-ap@panduit.com
Phone: 65.6305.7575

PANDUIT JAPAN
Tokyo, Japan
cs-japan@panduit.com
Phone: 81.3.6863.6000

PANDUIT LATIN AMERICA
Guadalajara, Mexico
cs-la@panduit.com
Phone: 52.33.3777.6000

PANDUIT AUSTRALIA PTY. LTD.
Victoria, Australia
cs-aus@panduit.com
Phone: 61.3.9794.9020

For a copy of Panduit product warranties, log on to www.panduit.com/warranty

For more information

Visit us at www.panduit.com

Contact Customer Service by email: cs@panduit.com
or by phone: 800.777.3300 and reference COSP225

PANDUIT®

©2012 Panduit Corp.
ALL RIGHTS RESERVED.
COSP225--WW-ENG
6/2012